

# Technical Data

## Specifications & Capacities

# 120|TT

Telescopic Boom Truck Crane

120 US ton

110 metric ton



**CAUTION:** This material is supplied for reference use only. Operator must refer to in-cab Crane Rating Manual and Operator's Manual to determine allowable crane lifting capacities and assembly and operating procedures.



# Table Of Contents

<b>Boom, Attachments, and Upper Structure</b> .....	<b>1</b>
Boom .....	1
Boom Wear Pads .....	1
Boom Head .....	1
Boom Elevation .....	1
Auxiliary Lifting Sheave - Optional .....	1
Heavy Duty Lifting Sheave Package - Optional .....	1
Hook Blocks and Balls - Optional .....	1
Fly - Optional .....	1
Fly Extensions - Optional .....	1
Upper Operator's Cab and Controls .....	2
Swing .....	3
Electrical .....	3
Load Hoist System .....	3
Load Hoist Performance .....	3
Main and Auxiliary Winches .....	3
Hydraulic System .....	4
Counterweight .....	4
<b>Carrier</b> .....	<b>7</b>
General .....	7
Outriggers .....	7
Steering and Axles .....	7
Suspension .....	7
Tires and Wheels .....	7
Brakes .....	7
Electrical .....	7
Engine .....	7
Transmission .....	7
Carrier Speeds and Gradeability .....	8
Fuel Tank .....	8
Hydraulic System .....	8
Pump Drive .....	8
Lower Cab and Controls .....	9
Additional Equipment .....	9
Transport Scenarios - Axle Loads .....	10
<b>General Dimensions</b> .....	<b>11</b>
EPA 2021 .....	11
<b>Working Range Diagram</b> .....	<b>12</b>
Main Boom + 9.5' Fly .....	12
Main Boom + Attachments .....	13

<b>Boom Extend Modes</b> .....	<b>14</b>
<b>Main Boom Lift Capacity Charts</b> .....	<b>15</b>
16,000 lb Counterweight - Fully Extended Outriggers - 360° Rotation .....	15
20,000 lb Counterweight - Fully Extended Outriggers - 360° Rotation .....	16
36,500 lb Counterweight - Fully Extended Outriggers - 360° Rotation .....	17
49,100 lb Counterweight - Fully Extended Outriggers - 360° Rotation .....	18
<b>Main Boom + Offset Fly Lift Capacity Charts</b> .....	<b>19</b>
49,100 lb Counterweight - Fully Extended Outriggers - 360° Rotation .....	19
Main Boom Length + 9.5 ft Manual Offset Fly (0°, 15°, 30°, 45°, Offset) .....	19
16,000 lb Counterweight - Fully Extended Outriggers - 360° Rotation .....	20
164.1 ft Main Boom Length .....	20
35 ft Manual Offset Fly .....	20
58 ft Manual Offset Fly .....	20
16,000 lb Counterweight - Fully Extended Outriggers - 360° Rotation .....	21
164.1 ft Main Boom Length .....	21
74 ft Manual Offset Fly .....	21
90 ft Manual Offset Fly .....	21
36,500 lb Counterweight - Fully Extended Outriggers - 360° Rotation .....	22
164.1 ft Main Boom Length .....	22
35 ft Manual Offset Fly .....	22
58 ft Manual Offset Fly .....	22
36,500 lb Counterweight - Fully Extended Outriggers - 360° Rotation .....	23
164.1 ft Main Boom Length .....	23
74 ft Manual Offset Fly .....	23
90 ft Manual Offset Fly .....	23
49,100 lb Counterweight - Fully Extended Outriggers - 360° Rotation .....	24
164.1 ft Main Boom Length .....	24
35 ft Manual Offset Fly .....	24
58 ft Manual Offset Fly .....	24
49,100 lb Counterweight - Fully Extended Outriggers - 360° Rotation .....	25
164.1 ft Main Boom Length .....	25
74 ft Manual Offset Fly .....	25
90 ft Manual Offset Fly .....	25
<b>Main Boom Lift Capacity Charts - Metric 75% ISO</b> .....	<b>26</b>
7.2t Counterweight - Fully Extended Outriggers - 360° Rotation .....	26
9t Counterweight - Fully Extended Outriggers - 360° Rotation .....	27
16.4t Counterweight - Fully Extended Outriggers - 360° Rotation .....	28
22.2t Counterweight - Fully Extended Outriggers - 360° Rotation .....	29
<b>Main Boom + Offset Fly Lift Capacity Charts - Metric 75% ISO</b> .....	<b>30</b>
22.2t Counterweight - Fully Extended Outriggers - 360° Rotation .....	30
Main Boom Length + 2.9m Manual Offset Fly (0°, 15°, 30°, 45°, Offset) .....	30
7.2t Counterweight - Fully Extended Outriggers - 360° Rotation .....	31
50.2m Main Boom Length .....	31
10.7m Manual Offset Fly .....	31
17.7m Manual Offset Fly .....	31
33.7m Manual Offset Fly .....	31
49.7m Manual Offset Fly .....	31

16.4t Counterweight - Fully Extended Outriggers - 360° Rotation .....	32
50.2m Main Boom Length .....	32
10.7m Manual Offset Fly .....	32
17.7m Manual Offset Fly .....	32
33.7m Manual Offset Fly .....	32
49.7m Manual Offset Fly .....	32
22.2t Counterweight - Fully Extended Outriggers - 360° Rotation .....	33
50.2m Main Boom Length .....	33
10.7m Manual Offset Fly .....	33
17.7m Manual Offset Fly .....	33
33.7m Manual Offset Fly .....	33
49.7m Manual Offset Fly .....	33
<b>Main Boom Lift Capacity Charts - Metric 85% .....</b>	<b>34</b>
7.2t Counterweight - Fully Extended Outriggers - 360° Rotation .....	34
9t Counterweight - Fully Extended Outriggers - 360° Rotation .....	35
16.4t Counterweight - Fully Extended Outriggers - 360° Rotation .....	36
22.2t Counterweight - Fully Extended Outriggers - 360° Rotation .....	37
<b>Manual Offset Fly Lift Capacity Charts - Metric 85% .....</b>	<b>38</b>
22.2t Counterweight - Fully Extended Outriggers - 360° Rotation .....	38
Main Boom Length + 2.9m Manual Offset Fly (0°, 15°, 30°, 45°, Offset) .....	38
7.2t Counterweight - Fully Extended Outriggers - 360° Rotation .....	39
50.2m Main Boom Length .....	39
10.7m Manual Offset Fly .....	39
17.7m Manual Offset Fly .....	39
33.7m Manual Offset Fly .....	39
49.7m Manual Offset Fly .....	39
16.4t Counterweight - Fully Extended Outriggers - 360° Rotation .....	40
50.2m Main Boom Length .....	40
10.7m Manual Offset Fly .....	40
17.7m Manual Offset Fly .....	40
33.7m Manual Offset Fly .....	40
49.7m Manual Offset Fly .....	40
22.2t Counterweight - Fully Extended Outriggers - 360° Rotation .....	41
50.2m Main Boom Length .....	41
10.7m Manual Offset Fly .....	41
17.7m Manual Offset Fly .....	41
33.7m Manual Offset Fly .....	42
49.7m Manual Offset Fly .....	42

# Boom, Attachments, and Upper Structure

## ■ Boom

**Design** - Six section, formed construction of extra high tensile steel consisting of one base section and five telescoping sections. The two plate design of each section has multiple longitudinal bends for superior strength. Each telescoping section extends independently by means of one double- acting, single stage hydraulic cylinder with integrated holding valves.

### Boom

- 38.3- 164.1 ft (11.7- 50.0m) six section boom
- Integral boom dolly connection
- Six boom extend modes (EM1 through EM6), controlled from the operator's cab, provide superior capacities by varying the extension of the telescoping sections:
  - EM1 extends to 164.1 ft (50.0m)
  - EM2 extends to 152.4 ft (46.5m)
  - EM3 extends to 140.3 ft (42.7m)
  - EM4 extends to 126.3 ft (38.5m)
  - EM5 extends to 114.6 ft (34.9m)
  - EM6 extends to 89.5 ft (27.3m)
- Mechanical boom angle indicator
- Maximum tip height for each extend mode is:
  - EM1 is 173 ft (52.6m)
  - EM2 is 161 ft (49.1m)
  - EM3 is 149 ft (45.5m)
  - EM4 is 136 ft (41.3m)
  - EM5 is 124 ft (37.8m)
  - EM6 is 99 ft (30.2m)

### Boom Wear Pads

- Wear pads with Teflon inserts that self- lubricate the boom sections
- Bottom wear pads are universal for all boom sections
- Top wear pads are universal for all boom sections

### Boom Head

- Five 16.5 in (41.9cm) root diameter nylon sheaves to handle up to ten parts of line
- Easily removable wire rope guards
- Rope dead end lugs on each side of the boom head
- Boom head is designed for quick- reeve of the hook block
- Wind speed indicator
- Aviation obstruction marking light and flag

### Boom Elevation

- One double acting hydraulic cylinder with integral holding valve
- Boom elevation: - 3° to 80°

### Auxiliary Lifting Sheave - Optional

- Single 16.5 in (41.9cm) root diameter nylon sheave
- Easily removable wire rope guards
- Does not affect erection of the fly or use of the main head sheaves

### Heavy Duty Lifting Sheave Package - Optional

- Necessary to achieve greater than 12 parts of line lifts
- Two 16.5 in (41.9cm) root diameter nylon sheaves
- Easily removable wire rope guards
- Does not affect use of the main head sheaves or auxiliary lifting sheave
- Cannot be used when fly is erected

### Hook Blocks and Balls - Optional

- 27 ton (25mt) 1 sheave quick- reeve hook block with safety latch
- 60 ton (55mt) 3 sheave quick- reeve hook block with safety latch
- 90 ton (82mt) 5 sheave quick- reeve hook block with safety latch
- 140 ton (127mt) 7 sheave quick- reeve hook block with safety latch
- 10 ton (9mt) swivel hook ball with safety latch

### Fly - Optional

- 9.5 ft- 35 ft (2.9m- 10.7m) two piece lattice fly, stowable, offsettable to 0°, 15°, 30°, and 45°. Maximum tip height is 207 ft (63m).
- 9.5 ft- 35 ft- 58 ft (2.9m- 10.7m- 17.7m) three piece lattice fly, stowable, offsettable to 0°, 15°, 30°, and 45°. Maximum tip height is 231 ft (70.3m).
- 35 ft (10.7m) one piece fly
- 35 ft- 58 ft (10.7m- 17.7m) two piece fly

### Fly Extensions - Optional

- One 16 ft (4.9m) lattice extension to be mounted between the boom head and fly options. Maximum tip height is 246 ft (75.0m).
- Two 16 ft (4.9m) lattice extensions to be mounted between the boom head and fly options. Maximum tip height is 262 ft (79.7m).

## ■ Upper Operator's Cab and Controls

**Environmental Cab** - Fully enclosed, one person cab of tubular and sheet steel structure with formed plastic interior panels.

Equipped with:

- Tinted and tempered glass windows
- Extra- large fixed front window with time delayed windshield wiper and washer
- Swing up roof window with windshield wiper and washer
- Sliding left side door with large fixed window
- Sliding right side window and pop- out rear window for ventilation
- Six way adjustable, cushioned seat with seat belt and storage compartment
- Diesel fired warm- water heater with ten air ducts for front windshield defroster and cab floor
- Air Conditioning - Integral with cab heating system utilizing the same ventilation outlets and automatic temperature control (ATC)
- Adjustable sun screen
- Dome lights with red nighttime reading LED's
- Cup holder
- Fire extinguisher
- Two position travel swing lock
- AM/FM Bluetooth radio

**Armrest Controls** - Two dual axis electronic joystick controllers or optional single axis electronic controllers for:

- Swing hoist
- Boom hoist
- Main (front) winch
- Auxiliary (rear) winch - optional
- Winch high/low speed switch(es)
- Warning horn button
- Swing park brake switch
- Engine throttle lock switch
- Engine set/resume switch
- Cab tilt
- Counterweight removal
- Hydraulic offset fly - optional

### Foot Controls

- Boom telescope
- Swing brake
- Engine throttle

**Upper Right Console** - Controls and indicators for:

- |                                     |                                |
|-------------------------------------|--------------------------------|
| • Engine ignition                   | • Radio                        |
| • Engine stop                       | • DRI on/off selection         |
| • Function lockout                  | • HVAC controller              |
| • Front windshield wiper and washer | • 360 swing lock - optional    |
| • Cab lights and upper frame lights | • Boom floodlights             |
| • Horn                              | • Rotating beacon/Strobe light |
| • Dome light with switch            | • Top hatch wiper washer       |
| • E- stop switch                    | • Winch(es) disable            |
|                                     | • Engine indicator gauge       |

### Rear Right Side Panel

- 12V accessory outlet (10amp)
- USB charge port

**Camera Display** - Located on the right A- post with an adjustable mount

- Displays right side of upper
- Displays main and auxiliary winches

**Diagnostic Center** - Located on the right rear wall behind the seat.

- Engine diagnostic
- RCL CANBUS diagnostic
- Boom CANBUS diagnostic
- Outrigger CANBUS diagnostic

**Fuse & Relay Panel** - Located on the left rear wall behind the seat.

**Link-Belt Pulse 2.0** – The Link-Belt in-house designed, total crane operating system that utilizes a 10 in touch screen color display with integrated RCL and engine data, advanced diagnostics and systems monitoring, Wi-Fi capable for remote software updates, operator customizable, and a readout and operator interface for the following systems:

- **Rated capacity limiter** – LCD graphic audio – visual warning system integrated into the dash with anti – two block and function limiter. Operating data includes:

- RCL controller USB diagnostic
- Crane configuration
- Boom length and angle
- Boom head height
- Allowed load and percent of allowed load
- RCL light bar
- Boom angle
- Radius of load
- Actual load
- Wind speed
- Highlighted unit of measurement on working screen
- Telescope operation displayed in real time
- Outrigger position sensing
- Drum rotation direction indication
- Third wrap indicator
- Diagnostics
- Counterweight detection system
- Operator settable alarms (include):
  - Maximum and minimum boom angles
  - Maximum tip height
  - Maximum boom length
  - Swing left/right positions
  - Operator defined area (imaginary plane)

### • Cab Instrumentation

- |  |                          |
|--|--------------------------|
| • Tachometer                               | • Swing park brake light |
| • Engine water temperature                 | • Engine speed           |
| • Fuel level                               | • Engine oil pressure    |
| • Hydraulic oil temperature                | • Battery voltage        |
| • Stop engine                              | • Fuel rate (gal/hr)     |
| • Check engine                             | • Engine load            |
| • Wait to start                            | • Engine diagnostics     |
| • Diesel exhaust fluid (DEF) level         |                          |
| • Engine air filter high restriction light |                          |
| • Regeneration light                       |                          |
| • Regeneration inhibit switch              |                          |
| • Regeneration initiate switch             |                          |
| • High exhaust temperature light           |                          |
| • Regeneration disabled light              |                          |

• **Telematics** – Cellular based data logging and monitoring system that provides:

- Location and operational settings
- Routine maintenance
- Crane and engine monitoring
- Diagnostic and fault codes

## ■ Swing

**Motor/Planetary** - Bi- directional, hydraulic swing motor mounted to a planetary reducer for 360° continuous smooth swing at 1.9 rpm.

**Swing Park Brake** - 360°, electric over hydraulic, (spring applied/hydraulic released) multi- disc brake mounted on the speed reducer. Operated by a switch from the operator's cab.

**Swing Brake** - 360°, foot operated, speed reducing system with disc brake hold feature.

**Swing Lock** - Two- position swing lock (0° and 180°) operated from the operator's cab.

**360° Positive Swing Lock - Optional** - Meets New York City requirement.

## ■ Electrical

**Swing Alarm** - Audio warning device signals when the upper is swinging.

## Lights

- Two working lights on front of the cab.
- One amber strobe beacon on top of the cab - optional
- Boom floodlight - Single - One high intensity floodlight mounted at the front portion of the boom base section. Adjustable to fixed positions.
- Boom floodlight - Dual - Two high intensity floodlights mounted at the front portion of the boom base section. Two adjustable to individual fixed positions.
- Boom floodlight package - Three high intensity floodlights mounted at the front portion of the boom base section. Two adjustable to individual fixed positions and one remote controlled.
- Work lighting package - Four high intensity work lights mounted on top of the operator's cab, the right side of the superstructure facing forward, on the upper work platform, and on the left side of the superstructure facing down.

## ■ Load Hoist System

### Load Hoist Performance

Main (Rear) and Auxiliary (Front) Winches - 3/4 in (19mm) Rope										
Layer	Maximum Line Pull		Normal Line Speed		High Line Speed		Layer		Total	
	lb	kN	ft/min	m/min	ft/min	m/min	ft	m	ft	m
1	23,632	105.12	150	45.7	241	73.5	115	35.1	115	35.1
2	21,616	96.15	164	50.0	264	80.5	125	38.1	240	73.2
3	19,917	88.60	178	54.3	286	87.2	136	41.5	376	114.6
4	18,465	82.14	192	58.5	309	94.2	147	44.5	522	159.1
5	17,211	76.56	206	62.8	331	100.9	157	47.9	679	207.0
6	16,116	71.69	220	67.1	354	107.9	168	51.2	847	258.2

Wire Rope Application		in	mm	Type	lb	kg
Main (Rear) Winch	Standard	3/4	19	37x7 rotation resistant - right lang lay (Type KC)	16,000	7 257.5
	Optional	3/4	19	35x7 rotation resistant - right lang lay (Type CC)	17,360	7 874.4
Auxiliary (Front) Winch	Standard	3/4	19	37x7 rotation resistant - right lang lay (Type KC)	16,000	7 257.5
	Optional	3/4	19	35x7 rotation resistant - right lang lay (Type CC)	17,360	7 874.4

## Main and Auxiliary Winches

- Axial piston (2- speed) motors driven through planetary reduction unit for positive control under all load conditions.
- Grooved lagging
- Power up/down mode of operation
- Hoist drum cable follower
- Drum rotation indicator
- Drum diameter: 15 in (38.1cm)
- Rope length:
  - Main: 730 ft (222.5m)
  - Auxiliary: 600 ft (182.9m)
- Maximum rope storage: 850 ft (259m)
- Terminator style socket and wedge

## ■ Hydraulic System

All circuits of the hydraulic system are pressure compensated.

**Counterbalance Valves** - All hoist motors, boom extend cylinders, and boom hoist cylinders are equipped with counterbalance valves to provide load lowering and to prevent accidental load drop if hydraulic power is suddenly reduced.

**Hydraulic Oil Cooler** - The carrier cooling package has an integrated hydraulic oil cooler. There is also an electric operated oil cooler in the upper for additional cooling capacity.

**Boom Hoist Float Valves** - For transporting the boom over the rear of the crane with a boom dolly. Allows hydraulic oil within the boom hoist cylinder to flow between piston side and case side, allowing the boom to float while on the boom dolly.

**Swing Brake Release** - For transporting the boom over the rear of the crane with a boom dolly. Holds the 360° swing park brake in the released position allowing free rotation of the upper structure.

## ■ Counterweight

**Standard** - Total of 16,500 lb (7.4t) of total counterweight consisting of four, hydraulically removable counterweights. Assembled and disassembled by hydraulic cylinders controlled from the operator's cab with capacities for:

- 0 lb (0t) counterweight
- 4,000 lb (1.8t) counterweight
- 8,000 lb (3.6t) counterweight
- 12,000 lb (5.4t) counterweight
- 16,000 lb (7.2t) counterweight

**Optional** - 20,000 lb (9t) in addition to standard counterweight for a total of 36,500 lb (16.4t) with additional capacities for:

- 20,000 lb (9t) counterweight
- 24,000 lb (10.8t) counterweight
- 28,000 lb (12.7t) counterweight
- 32,500 lb (14.7t) counterweight
- 36,500 lb (16.4t) counterweight

**Optional** - 32,600 lb (14.8t) in addition to standard counterweight for a total of 49,100 lb (22.2t) with additional capacities for:

- 20,000 lb (9t) counterweight
- 24,000 lb (10.8t) counterweight
- 28,000 lb (12.7t) counterweight
- 32,000 lb (14.4t) counterweight
- 36,500 lb (16.4t) counterweight
- 49,100 lb (22.2t) counterweight\*

Low speed jobsite travel is offered for these optional counterweight configurations and a boom dolly or boom trailer may be required for on- highway travel.

\* Overall width of the crane increases to 13 ft 10.8 in (4.24m) for this counterweight configuration

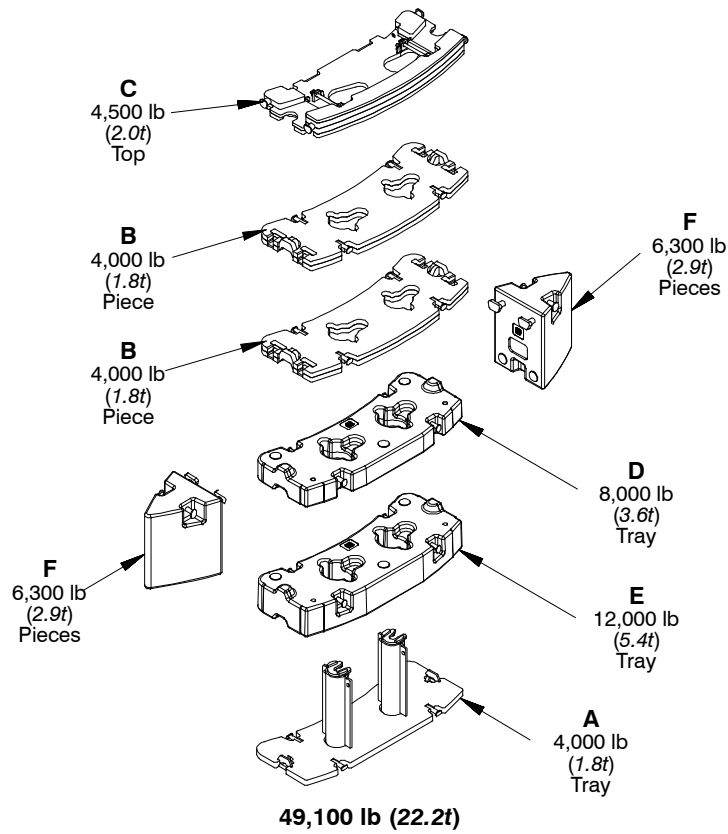

**Allowed Counterweight Combinations - Standard**

0				
4,000 lb (1.8t)	A	C		
8,000 lb (3.6t)	AB	AC		
12,000 lb (5.4t)	ABB	ABC	AD	
16,000 lb (7.2t)	ABBC	ABD	AE	ACD
20,000 lb (9t)	ABBD	ABCD	ABE	ACE
24,000 lb (10.8t)	ABBE	ABCE	ABBCD	
28,000lb (12.7t)	ABBCE	ABDE	ACDE	
32,000lb (14.4t)	ABBDE	ABCDE		
36,500lb (16.4t)	ABBCDE			
49,100lb (22.2t)	ABBCDEFF			

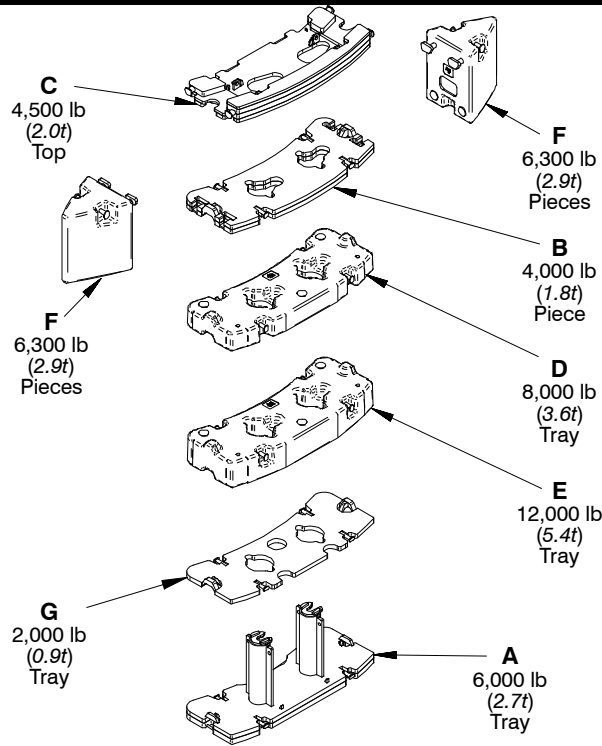

49,100 lb (22.2t)

**Allowable Counterweight Combinations - California Special**

0				
4,500 lb (2.0t)	C			
6,000 lb (2.7t)	A			
8,000 lb (3.6t)	AG			
10,000 lb (4.5t)	AC	AB		
12,000 lb (5.4t)	AGB	AGC		
16,000 lb (7.2t)	AGBC	AGD		
20,000 lb (9t)	AGBD	AGCD	AGE	
24,000 lb (10.8t)	AGBE	AGCE	AGBCD	
28,000lb (12.7t)	AGBCE	AGDE		
32,000lb (14.4t)	AGBDE	AGCDE		
36,500lb (16.4t)	AGBCDE			
49,100lb (22.2t)	AGBCDEFF			

# Carrier

## General

- 8 ft 6 in (2.6m) wide
- 23 ft 5.5 in (7.14m) wheelbase (centerline of first axle to centerline of fourth axle)
- **Frame** - Box- type, torsion resistant, welded construction made of high tensile steel. Equipped with front and rear towing and tie- down lugs, tow connections, and access ladders.

## Outriggers

**Boxes** - Two double box, front and rear welded to the carrier frame.

**Beams and Jacks** - Four dual stage beams with Variable Confined Area Lifting Capacities (V- CALC) provide selectable outrigger extensions of full, intermediate, and retracted positions. 81 possible outrigger configurations. Jacks with integral check valves, hydraulically controlled from the operator's cab and on both sides of carrier. A fifth front bumper outrigger 16 in (40.6cm) diameter, self- storing with integral check valves is hydraulically controlled from the upper operator's cab and at the front bumper of carrier.

### Pontoons

- **Main** - Four lightweight, stow'n go, 23.5" x 27.25" (59.7 x 69.2cm) hexagonal steel pontoons with a contact area of 443 in<sup>2</sup> (2 858cm<sup>2</sup>) can be stored for road travel in either the storage racks on the carrier or under the outrigger boxes
- **Front Bumper** - One, lightweight, self- storing, 16" (40.6cm) diameter steel pontoon with a contact area of 199 in<sup>2</sup> (1 284cm<sup>2</sup>)

### Jack Reaction

- **Main** - 122,000 lb (542.7kN) force and 276 psi (1 903kPa) ground bearing pressure
- **Front Bumper** - 40,000 lb (177.9kN) force and 201 psi (1 386kPa) ground bearing pressure

## Steering and Axles

- Dual gear steering system provides hydraulic assisted steering with mechanical link between steering wheel and wheels
- **Drive** - 8 x 4 for on/off- highway travel
- **Axle 1 & 2** - Tandem steered, non- driven
- **Axle 3 & 4** - Tandem steered, driven with reduction: 7.5 to 1
- **Inter- Axle Differential Lock** - Locks axle 3 with axle 4. Operated by a switch from the carrier cab.
- Cross axle lock on axles 3 and 4

## Suspension

**Front** - Independent air suspension

**Rear** - Independent air suspension

## Tires and Wheels

**Front** - Four (single) 445/65R22.5 tires on aluminum disc wheels

**Rear** - Four (single) 445/65R22.5 tires on aluminum disc wheels

- Spare tires and wheels - optional
- Tire inflation kit - optional

## Brakes

**Service** - Full air anti- lock (ABS) disc brakes on all wheel ends. Dual circuit compressed air system with air dryer.

**Parking/Emergency** - Spring loaded type, acting on 3<sup>rd</sup> and 4<sup>th</sup> axles automatically apply when air pressure drops below 60 psi (413.7kPa) in both circuits.

## Electrical

**Battery** - Four batteries provide 24 volt starting and operation, easily accessible battery disconnects, and battery charging posts.

### Lights

- Front lighting includes two main daytime running/headlights, two high beam lights, two parking/directional indicators, and three cab marker lights.
- Side lighting includes three parking/directional indicators per side.
- Rear lighting includes two parking/directional indicators, two parking/brake lights, two reverse lights, three marker lights, and a license plate light.
- Other equipment includes hazard/warning system, LED light, instrument panel light, signal horn, carrier cab door courtesy light, and two outrigger LED lights on each side.
- One amber strobe beacon behind the cab
- Compartment lighting inside storage boxes, outrigger control boxes, and fuel fill.

## Engine

Specification	Cummins X12
Emissions Compliance Level:	EPA 2021
Maximum Allowable Sulfur Content of Fuel (PPM):	15
Numbers of cylinders:	6
Cycle:	4
Bore and Stroke: inch (mm)	5.2 x 5.67 in (132 x 144mm)
Piston Displacement: in <sup>3</sup> (L)	720 (11.8L)
Max. Brake Horsepower: hp (kW)	445 (339) @ 1,600 rpm 410 (306) @ 2,000 rpm
Peak Torque: ft lb (Nm)	1,550 (2 102) @ 1,200 rpm
Alternator: volts - amps	24 - 140
Crankcase Capacity: qt (L)	46 (43.5)

- Cruise control
  - Cummins X12 three stage engine compression brake
  - Thermostatically controlled, hydraulically driven radiator fan
  - 120 volt engine block heater - X12
  - Ether injection system - optional on X12
  - Grid heater starting aid standard on X12
  - Engine equipped with on-board diagnostics - X12
- (1) Can only be sold and/or operated where EPA2021 on- highway emission standards are accepted.

## Transmission

**Automated** - ZF TRAXON (no clutch pedal) manual transmission with 12 forward gears and 2 reverse gears.

## Carrier Speeds and Gradeability

ZF Traxon		Governed Speed		Gradeability (At Peak Torque Except Creep at Idle)	
		EPA 2021			
Gear	Ratio	mph	km/h	EPA 2021	
12th	0.77	61	98	1.6	
11th	1.00	47	76	2.5	
10th	1.30	36	58	3.7	
9th	1.68	28	45	4.9	
8th	2.19	22	35	6.7	
7th	2.83	17	27	8.9	
6th	3.53	13	22	11.2	
5th	4.57	10	17	14.7	
4th	5.94	8	13	19.3	
3rd	7.69	6	10	25.2	
2nd	9.98	5	8	33.0	
1st	12.92	4	6	39.0	
Reverse 1	12.03	4	6	39.3	
Reverse 2	9.29	5	8	30.6	
Creep at idle	2nd	9.98	2	3	16.9
	1st	12.92	1	2	22.0
	Reverse 1	12.03	1	2	20.5
	Reverse 2	9.29	2	3	15.7

Based on a gross vehicle weight of 107,250 lb (48 647.8kg)

### Fuel Tank

- One 95 gal (359.6L) capacity tank
- One 10 gal (37.8L) capacity diesel exhaust fluid (DEF) plastic tank (EPA 2021)

### Hydraulic System

All functions are hydraulically powered allowing positive, precise control with independent or simultaneous operation of all functions.

#### Main Pumps

- Two variable displacement load sense piston pumps that drive the boom hoist, boom extend, winches, and the cooling package fan. One piston pump is engine driven to allow boom and winch operation during pick and carry operations.
- One fixed displacement gear pump for steering
- One fixed displacement gear pump for swing operation
- One fixed displacement gear pump for the outriggers and the upper air conditioner and counterweight removal circuits
- Combined pump capacity of 168 gpm (635.9Lpm)

**Hydraulic Reservoir** - 128 gal (484.5L) capacity equipped with sight level gauge. Diffusers built in for deaeration.

**Filtration** - One 10 micron, full flow, return line filter. All oil is filtered prior to return to reservoir. Accessible for easy filter replacement.

### Pump Drive

All pumps are mechanically driven by the diesel engine. Main and auxiliary winches, swing, boom hoist, control circuit, and telescope pumps are mounted to an automatic pump disconnect on the rear of the transmission to aid in cold weather starting as well as to reduce pump wear while traveling.

## ■ Lower Cab and Controls

**Environmental Cab** - Fully enclosed, single occupancy cab of aluminum construction with acoustical insulation.

Equipped with:

- Tinted and tempered glass windows
- Power left and right door windows for ventilation
- Intermittent windshield wiper and washer
- Six way adjustable and air suspended driver's seat with seat belt
- Two heated and electrically adjustable side view mirrors with passenger infrared camera
- Engine dependent warm- water heater with air ducts for chest/face, foot, and windshield defroster
- Adjustable sun visor
- LED dome lights
- Fire extinguisher

**Air Conditioning** - Integral with cab heating system utilizing the same ventilation outlets

- Automatic temperature control

**Overhead Console** - Located above the sun visor

- AM/FM Bluetooth radio
- Dome light switch
- 12V accessory power outlet

**Camera Display** - Integrated with right side LCD display

- Displays right side of machine
- Displays rear view
- Displays dolly rear view

**Cab Instrumentation** - Ergonomically positioned instrumentation for driving including:

- Digital speedometer with odometer, hour meter, trip meter, clock and outside temperature.
- Tachometer
- Fuel and diesel exhaust fluid (DEF) level with warning indicator

**Indicator Lights**

- Regeneration inhibit
- Check engine
- Stop engine
- Exhaust regeneration
- High exhaust temperature
- Engine air filter high restriction light
- Cruise
- Park brake
- Tire pressure warning
- ABS
- Trailer ABS
- Engine brake level
- Transaxle (cross- axle) differential lock
- Inter- axle differential lock
- Travel mode
- Ride height
- Diesel Exhaust Fluid (DEF)
- Seat belt
- Hill hold start

**Dash Mounted Controls For:**

- Carrier lights
- Console dimmer switch
- Remote mirror control switches
- Mirror heating switch
- Cab heater/air conditioning switch
- Fresh/Recirculation air switch
- Park brake air valve
- Trailer brake air valve
- Carrier engine ignition switch

**Dash Mounted Indicators For:**

- Turn signal indication
- High beam headlights

**Right Side LCD Display** - Ergonomically positioned on the right of driver's dash panel, digital instrumentation and indicators for crane operations including:

- Transmission digital readout
- **Gauges**
  - Engine water temperature
  - Engine oil pressure

**Diagnostic Screens**

- Engine
- Aftertreatment
- Outriggers
- Tire Pressure Monitoring Screen (TPMS)

**Right Side Console** - Controls and indicators for:

- Transmission gear shifting
- Diesel particulate filter switch
- Regeneration inhibit switch
- Fan override switch
- ABS Traction control switch
- Transaxle (cross- axle) differential lock switch with indicator light
- Inter- axle differential lock switch with indicator light
- Travel mode switch
- Ride height switch
- Hill hold start switch
- Rear Steer Axle Lock
- Rear Axle Steering Switch

**Steering Column/Wheel Controls For:**

- Turn signal switch
- High beam switch
- Tilt/telescope adjustments
- Cruise Control
- Engine brake control
- Warning horn
- Hazard light switch
- Intermittent windshield wiper and washer

**Foot Controls For:**

- Carrier service brakes
- Engine throttle

## ■ Additional Equipment

**Standard:**

- Aluminum full deck fenders with mud flaps
- Left and right bubble levels
- Air hose connection ports
- Clearance flags
- Five storage compartments
  - Storage compartment behind carrier cab
  - Left and right side ladders
  - Storage box between axles 3 and 4 on the left and right sides
- Pneumatic and electrical quick disconnect connectors mounted on the rear for trailer or boom dolly brakes and lights
- Wireless rigging remote control with digital inclinometer
  - controls outrigger beams, jacks, boom hoist, main and auxiliary winch.

**Optional:**

- Rear mounted pintle hook
- Trailer rear view camera

# Transport Scenarios - Axle Loads



Base crane: Includes: 250 lb driver, oversize load signs, two winches with cable followers, 730' wire rope on main winch, 600' wire rope on auxiliary winch, no counterweight, 35- 58' two piece offset fly, auxiliary lifting sheave, 60 T hook block, 10 T hookball, and 500 lb rigging		Gross Vehicle Weight		Front Tandem		Rear Tandem	
		lb	kg	lb	kg	lb	kg
		90,229	40,927	44,041	19,978	46,188	20,951
Add	4,000 lb counterweight on carrier	4,000	1,814	3,108	1,410	892	405
	6,000 lb counterweight on carrier*	6,000	2,722	4,662	2,115	1,338	607
	8,000 lb counterweight on carrier	8,000	3,629	6,216	2,820	1784	809
	4,000 lb counterweight on carrier rear	4,000	1,814	- 1,607	- 729	5,607	2,543
	4,500 lb counterweight on upper	4,500	2,041	- 2,399	- 1,088	6,899	3,129
Substitute	9.5' - 35' - 58' 3 piece offset fly	531	241	715	324	- 184	- 83
Remove	35- 58' 2 piece offset fly	- 2,636	- 1,196	- 2,494	- 1,131	- 142	- 64
	60 T hook block	- 1,150	- 522	- 1,961	- 889	811	368
	10 T hookball	- 584	- 265	- 996	- 452	412	187

\*Requires California Counterweight Package



Base crane: Includes: 250 lb driver, oversize load signs, two winches with cable followers, 730' wire rope on main winch, 600' wire rope on auxiliary winch, no counterweight, 35- 58' two piece offset fly, auxiliary lifting sheave, 60 T hook block, 10 T hookball, 500 lb rigging, and 9,000 lb 3- axle close couple dolly. (Boom extended 2' in travel mode)		Gross Vehicle Weight		Front Tandem		Rear Tandem		Dolly	
		lb	kg	lb	kg	lb	kg	lb	kg
		99,264	45,026	31,188	14,147	38,443	17,438	29,633	13,441
Add	36,500 lb of counterweight (28,500 lb on dolly, 8,000 lb on carrier)	36,500	16,556	6,217	2,820	1,783	809	28,500	12,927
	16,500 lb of counterweight (8,500 lb on dolly, 8,000 lb on carrier)	16,500	7,484	6,217	2,820	1,783	809	8,500	3,856
Substitute	9.5' - 35' - 58' 3 piece offset fly	531	241	15	7	15	7	501	227
Remove	35- 58' 2 piece offset fly	-2,636	-387	-2,494	-385	142	64	-1,864	-845
	60 T hook block	-1,150	-522	126	57	126	57	-1,402	-636
	10 T hookball	-584	-265	64	29	64	29	-712	-323

# General Dimensions

## EPA 2021

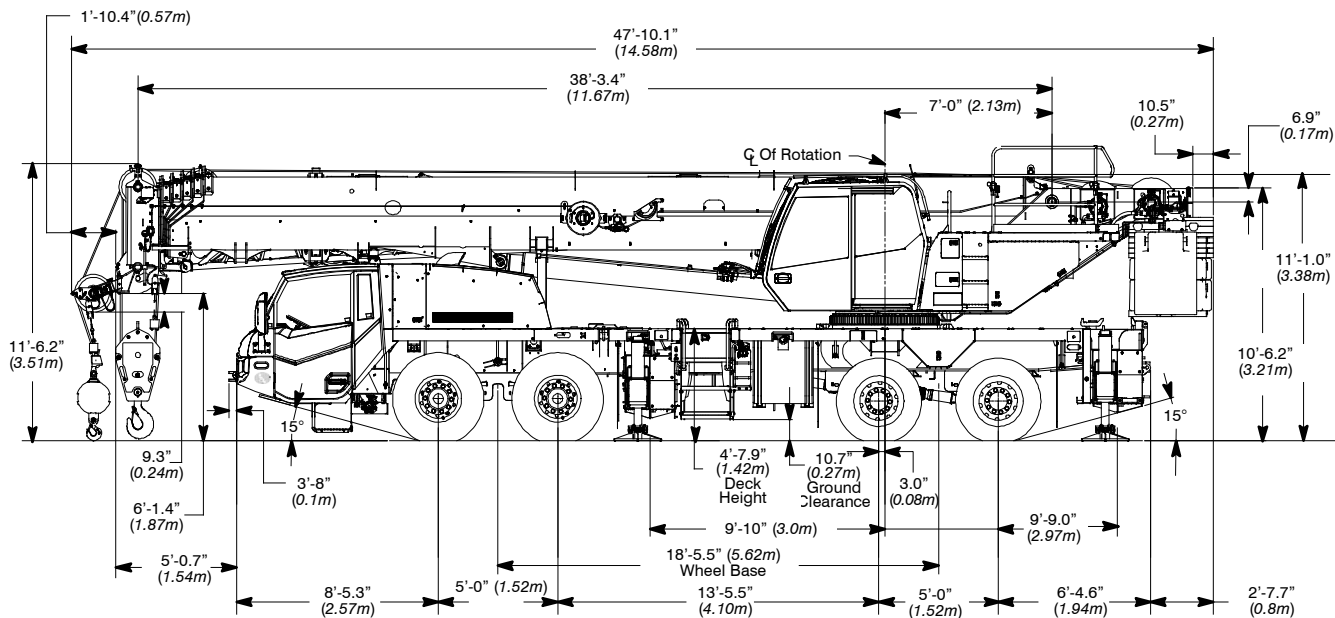

Turning Radius	English	Metric
Wall to wall over carrier	38'-3.46"	11.7m
Wall to wall over boom	39'-7.5"	12.1m
Wall to wall over boom attachment	40'-8.1"	12.4m
Curb to curb	27'-7.4"	8.4m
Centerline of tire	26'-9.7"	8.2m

Tail Swing	English	Metric
With counterweight	13' 9"	4.2m
Without counterweight	13' 0"	4.0m

Overall Width	English	Metric
With up to 36,500 lb (16 556.1kg) counterweight	8' 6"	2.6m
With 49,100 lb (22 271.4kg) counterweight	13' 11"	4.2m

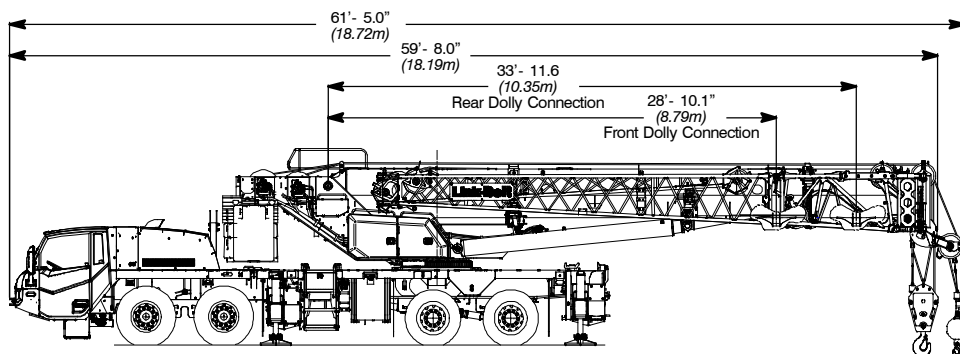
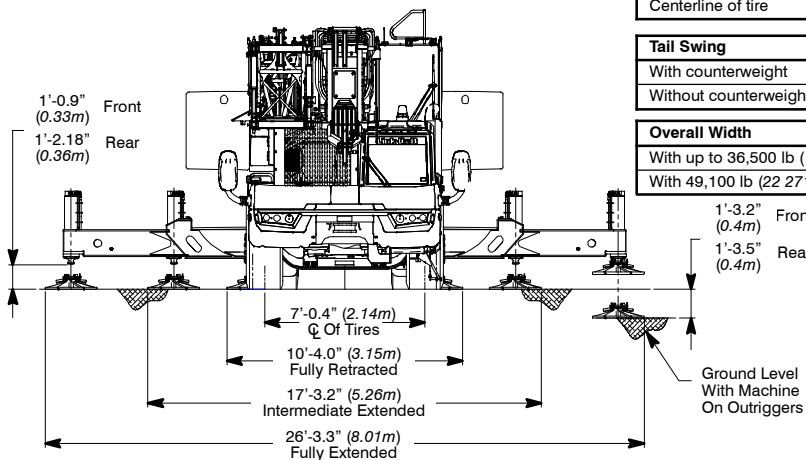

Not To Scale

# Working Range Diagram

## Main Boom + 9.5' Fly

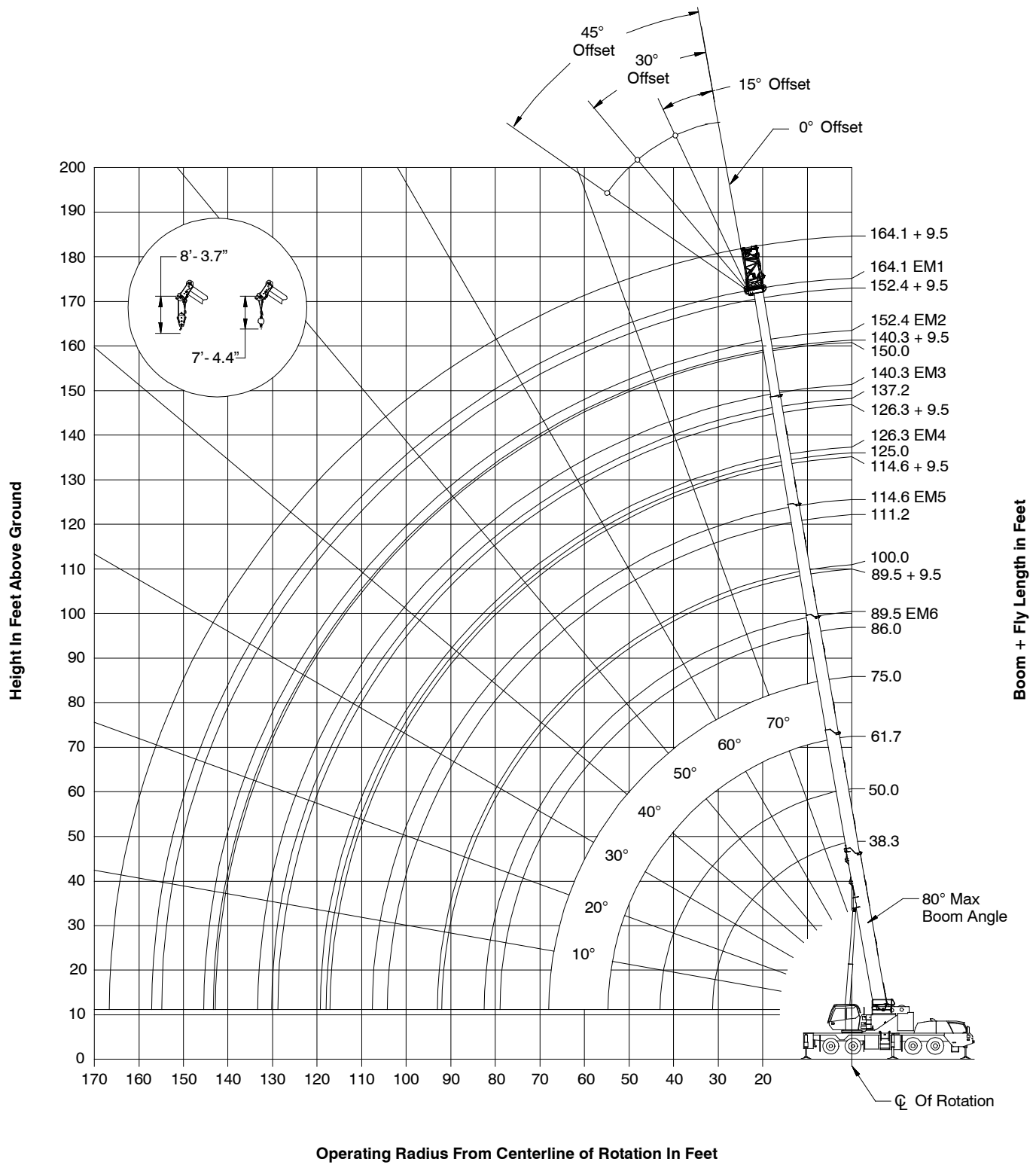

# Working Range Diagram Main Boom + Attachments

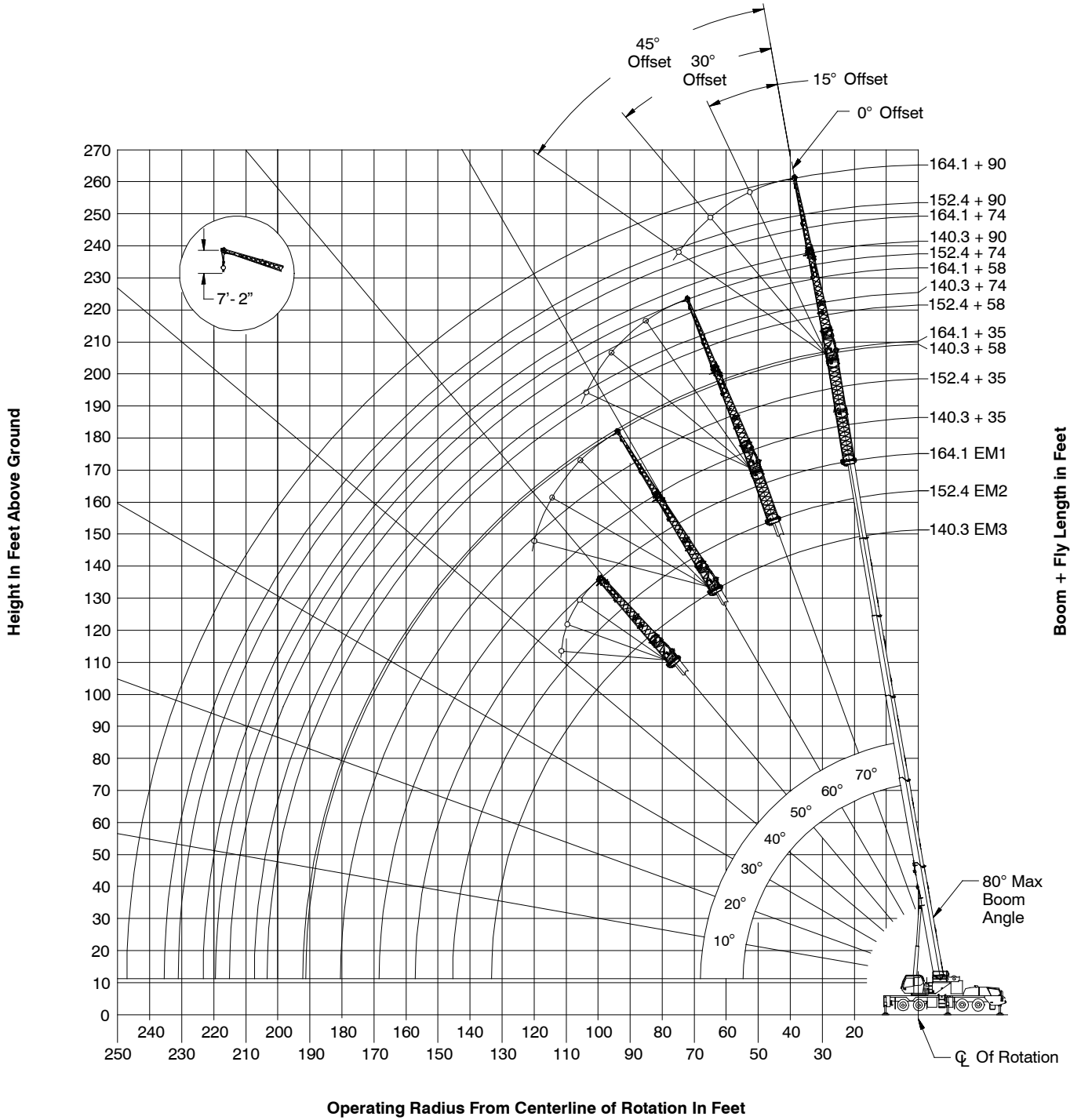

# Boom Extend Modes

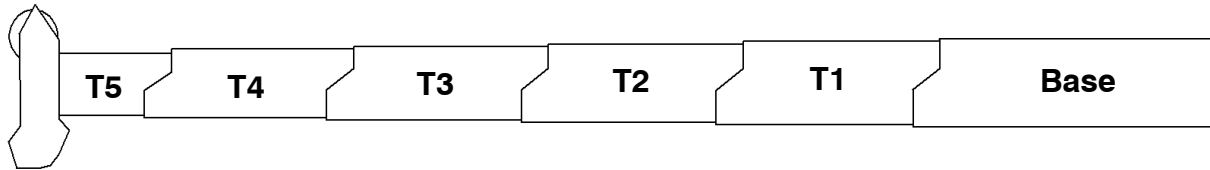

<b>EM 1</b>							
	Boom Length (ft)	Boom Length (m)	Section Length				
			T5	T4	T3	T2	T1
*	38.3	11.68					
	50	15.24	50%				
*	61.7	18.81	100%				
	75	22.87	100%	55%			
*	86	26.22	100%	100%			
	100	30.49	100%	100%	56%		
*	111.2	33.90	100%	100%	100%		
	125	38.11	100%	100%	100%	53%	
*	137.2	41.83	100%	100%	100%	100%	
	150	45.73	100%	100%	100%	100%	48%
*	164.1	50.03	100%	100%	100%	100%	100%

<b>EM 2</b>							
	Boom Length (ft)	Boom Length (m)	Section Length				
			T5	T4	T3	T2	T1
*	38.3	11.68					
*	50	15.24	50%				
	60	18.29	50%	41%			
*	74.3	22.65	50%	100%			
	85	25.91	50%	100%	43%		
*	99.5	30.34	50%	100%	100%		
	110	33.54	50%	100%	100%	40%	
*	125.5	38.26	50%	100%	100%	100%	
	140	42.68	50%	100%	100%	100%	54%
*	152.4	46.46	50%	100%	100%	100%	100%

<b>EM 3</b>							
	Boom Length (ft)	Boom Length (m)	Section Length				
			T5	T4	T3	T2	T1
*	38.3	11.68					
*	50	15.24	50%				
*	62.1	18.93	50%	50%			
	75	22.87	50%	50%	51%		
*	87.3	26.62	50%	50%	100%		
	100	30.49	50%	50%	100%	49%	
*	113.4	34.57	50%	50%	100%	100%	
	125	38.11	50%	50%	100%	100%	43%
*	140.3	42.77	50%	50%	100%	100%	100%

<b>EM 4</b>							
	Boom Length (ft)	Boom Length (m)	Section Length				
			T5	T4	T3	T2	T1
	38.3	11.68					
	50	15.24	50%				
	61.7	18.81	100%				
	73.8	22.50	100%	50%			
	86.4	26.34	100%	50%	50%		
	99.4	30.30	100%	50%	50%	50%	
	115	35.06	100%	50%	50%	50%	
	126.3	38.51	100%	50%	50%	50%	

<b>EM 5</b>							
Boom Length (ft)	Boom Length (m)	Section Length					
		T5	T4	T3	T2	T1	
38.3	11.68						
50	15.24	50%					
62.1	18.93	50%	50%				
74.7	22.77	50%	50%	50%			
87.8	26.77	50%	50%	50%	50%		
100	30.49	50%	50%	50%	50%	46%	
114.6	34.94	50%	50%	50%	50%	100%	

<b>EM 6</b>							
Boom Length (ft)	Boom Length (m)	Section Length					
		T5	T4	T3	T2	T1	
38.3	11.68						
50.5	15.40	0%	50%				
63	19.20	0%	50%	50%			
76.1	23.20	0%	50%	50%	50%		
89.5	27.29	0%	50%	50%	50%	50%	

\* Denotes boom lengths charted with 35 ft (10.7m), 58 ft (17.7m), 74 ft (22.6m), and 90 ft (27.4m) fly.

# Main Boom Lift Capacity Charts

16,000 lb Counterweight - Fully Extended Outriggers - 360° Rotation (All Capacities Are Listed In Pounds)												
Radius (ft)	Boom Length (ft)											Radius (ft)
	38.3	49.99-50.45	60-63.03	73.84-76.05	85-89.50	99.44-100	110-115	125-126.34	137.20-140.25	150.0-152.41	164.1	
10	168,800	160,700	137,600									10
12	143,800	144,200	137,600	120,400								12
15	115,000	116,500	115,900	113,800	91,500							15
20	84,400	86,700	87,000	86,100	84,300	65,800	50,500					20
25	65,200	67,900	68,500	68,000	68,900	65,800	50,500	38,800	25,400			25
30	47,200	51,200	53,600	54,000	53,500	52,400	50,500	38,800	30,800	24,400		30
35		39,500	41,300	41,700	41,200	41,500	40,100	38,800	30,800	24,400	19,600	35
40		31,100	33,000	33,400	33,600	34,000	32,900	32,900	30,800	24,400	19,600	40
45			27,000	27,600	28,600	28,400	28,000	28,000	26,700	24,400	19,600	45
50			22,700	24,000	24,100	23,900	24,200	24,100	23,700	22,500	19,600	50
55			18,900	20,500	20,600	21,100	21,100	20,600	20,200	19,500	18,900	55
60				17,600	18,200	18,200	18,200	17,700	17,400	16,600	16,000	60
65				15,200	15,800	15,800	15,800	15,400	15,100	14,400	13,800	65
70					13,800	13,900	13,900	13,500	13,100	12,500	11,800	70
75					12,100	12,200	12,200	11,800	11,500	10,800	10,200	75
80					9,400	10,800	10,800	10,400	10,000	9,400	8,800	80
85						9,500	9,600	9,100	8,800	8,200	7,600	85
90						8,400	8,500	8,100	7,800	7,100	6,500	90
95							7,500	7,100	6,800	6,200	5,600	95
100							6,600	6,300	6,000	5,400	4,800	100
105							4,100	5,500	5,200	4,600	4,100	105
110								4,800	4,600	4,000	3,400	110
115								4,200	3,900	3,400	2,800	115
120									3,400	2,800	2,300	120
125									2,900	2,300	1,800	125
130									2,400	1,800	1,300	130
135										1,400		135
140										1,000		140

This information is not for crane operation. Operator must refer to the in- cab information for crane operation. Rated lifting capacities shown on fully extended outriggers do not exceed 85% of the tipping loads and on tires do not exceed 75% of the tipping loads.

20,000 lb Counterweight - Fully Extended Outriggers - 360° Rotation (All Capacities Are Listed In Pounds)												
Radius (ft)	Boom Length (ft)											Radius (ft)
	38.3	49-50.5	60-63	73.8-76.1	85-89.5	99.4-100	110-115	125-126.3	137.2-140.2	150.0-152.4	164.1	
10	169,200	160,700	137,600									10
12	147,100	144,200	137,600	120,400								12
15	117,700	116,500	118,400	113,600	91,500							15
20	86,500	86,700	89,100	88,100	86,300	65,800	50,500					20
25	67,000	67,900	70,200	69,700	70,500	65,800	50,500	38,800	25,400			25
30	50,900	51,100	57,100	57,700	57,200	56,100	50,500	38,800	30,800	24,400		30
35		39,400	44,300	44,600	44,200	43,200	42,200	38,800	30,800	24,400	19,600	35
40		31,100	35,400	35,900	36,000	35,600	35,300	34,600	30,800	24,400	19,600	40
45			26,100	29,600	30,300	30,200	30,100	29,700	28,300	24,400	19,600	45
50			24,300	25,600	26,000	25,700	25,300	25,900	25,400	23,600	19,600	50
55			20,500	22,100	22,200	22,000	22,400	22,200	21,900	21,200	19,600	55
60				19,100	19,200	19,700	19,700	19,200	18,900	18,200	17,600	60
65				16,600	17,100	17,300	17,300	16,800	16,500	15,800	15,300	65
70					15,200	15,300	15,300	14,900	14,500	13,900	13,300	70
75					13,400	13,500	13,500	13,100	12,800	12,100	11,500	75
80					10,600	12,000	12,000	11,600	11,300	10,600	10,000	80
85						10,600	10,700	10,300	9,900	9,300	8,700	85
90						9,500	9,500	9,100	8,800	8,200	7,600	90
95							8,500	8,100	7,800	7,200	6,600	95
100							7,600	7,200	6,900	6,300	5,700	100
105							5,000	6,400	6,100	5,500	4,900	105
110								5,700	5,400	4,800	4,200	110
115								5,000	4,700	4,200	3,600	115
120									4,100	3,600	3,000	120
125									3,600	3,000	2,500	125
130									3,100	2,500	2,000	130
135										2,100	1,600	135
140										1,700	1,200	140

This information is not for crane operation. Operator must refer to the in- cab information for crane operation. Rated lifting capacities shown on fully extended outriggers do not exceed 85% of the tipping loads and on tires do not exceed 75% of the tipping loads.

36,500 lb Counterweight - Fully Extended Outriggers - 360° Rotation (All Capacities Are Listed In Pounds)												
Radius (ft)	Boom Length (ft)										Radius (ft)	
	38.3	49.99-50.45	60-63.03	73.84-76.05	85-89.50	99.44-100	110-115	125-126.34	137.20-140.25	150-152.41		164.1
10	171,100	160,700	137,600									10
12	154,700	147,300	137,600	120,400								12
15	128,900	130,100	125,000	120,400	91,500							15
20	95,200	97,300	97,400	96,200	91,500	65,800	50,500					20
25	74,100	76,600	77,200	76,500	75,100	65,800	50,500	38,800	25,400			25
30	59,500	62,300	63,100	62,700	63,600	62,500	50,500	38,800	30,800	24,400		30
35		51,900	52,800	54,100	53,600	52,600	46,400	38,800	30,800	24,400	19,600	35
40		43,100	45,600	46,000	45,500	44,600	41,900	38,300	30,800	24,400	19,600	40
45			37,700	38,300	37,800	36,900	36,100	35,300	30,800	24,400	19,600	45
50			31,900	32,400	32,000	32,200	31,800	31,400	29,600	24,400	19,600	50
55			27,300	27,800	28,000	28,500	27,500	26,900	27,200	24,400	19,600	55
60				24,200	25,000	24,900	24,300	24,000	23,600	23,100	19,600	60
65				21,100	22,300	21,900	21,800	21,400	21,400	21,300	19,600	65
70					19,700	19,600	19,300	19,900	19,500	18,900	18,200	70
75					17,600	17,500	17,200	17,700	17,400	16,800	16,100	75
80					15,000	16,100	16,000	15,900	15,700	15,100	14,500	80
85						14,800	14,800	14,500	14,200	13,500	13,000	85
90						13,400	13,400	13,100	12,800	12,200	11,600	90
95							12,200	11,800	11,600	11,000	10,400	95
100							11,100	10,700	10,500	9,900	9,300	100
105							8,400	9,700	9,500	8,900	8,400	105
110								8,900	8,600	8,100	7,500	110
115								8,100	7,800	7,300	6,700	115
120									7,100	6,500	6,000	120
125									6,400	5,900	5,400	125
130									5,900	5,300	4,800	130
135										4,700	4,200	135
140										4,200	3,700	140
145										2,700	3,200	145
150											2,800	150
155											2,400	155

This information is not for crane operation. Operator must refer to the in- cab information for crane operation. Rated lifting capacities shown on fully extended outriggers do not exceed 85% of the tipping loads and on tires do not exceed 75% of the tipping loads.

49,100 lb Counterweight - Fully Extended Outriggers - 360° Rotation (All Capacities Are Listed In Pounds)												
Radius (ft)	Boom Length (ft)											Radius (ft)
	38.3	49.99-50.45	60-63.03	73.84-76.05	85-89.50	99.44-100	110-115	125-126.34	137.20-140.25	150-152.41	164.1	
7	240,000											7
8	205,000											8
9	180,000											9
10	172,400	160,700	137,600									10
12	156,100	147,300	137,600	120,400								12
15	135,900	130,800	125,000	120,400	91,500							15
20	101,800	103,900	103,800	102,500	91,500	65,800	50,500					20
25	79,500	81,900	82,400	81,600	80,100	65,800	50,500	38,800	25,400			25
30	64,100	66,800	67,500	67,100	65,900	65,800	50,500	38,800	30,800	24,400		30
35		55,800	56,600	57,400	57,400	56,400	46,400	38,800	30,800	24,400	19,600	35
40		47,400	48,700	49,700	49,300	48,300	41,900	38,300	30,800	24,400	19,600	40
45			42,900	43,300	42,900	42,100	38,000	35,300	30,800	24,400	19,600	45
50			37,600	38,000	37,700	36,900	34,700	33,100	29,600	24,400	19,600	50
55			31,300	32,900	32,700	31,800	31,100	30,800	27,500	24,400	19,600	55
60				28,800	28,600	28,700	28,500	27,900	25,700	23,800	19,600	60
65				25,400	25,100	25,800	25,100	24,500	24,000	22,500	19,600	65
70					22,300	23,200	22,400	21,700	22,100	21,500	19,600	70
75					21,100	20,800	20,000	19,600	19,700	20,200	19,000	75
80					18,300	18,700	18,700	18,400	17,700	18,300	17,700	80
85						16,900	16,900	16,700	16,600	16,500	15,900	85
90						15,400	15,400	15,800	15,600	15,100	14,500	90
95							14,000	14,600	14,300	13,700	13,200	95
100							12,800	13,300	13,100	12,500	11,900	100
105							10,800	12,200	11,900	11,400	10,800	105
110								11,200	10,900	10,400	9,900	110
115								10,300	10,000	9,500	9,000	115
120									9,200	8,700	8,100	120
125									8,500	7,900	7,400	125
130									7,700	7,200	6,700	130
135										6,600	6,100	135
140										6,000	5,500	140
145										4,400	5,000	145
150											4,500	150
155											4,000	155

This information is not for crane operation. Operator must refer to the in- cab information for crane operation. Rated lifting capacities shown on fully extended outriggers do not exceed 85% of the tipping loads and on tires do not exceed 75% of the tipping loads.

# Main Boom + Offset Fly Lift Capacity Charts

49,100 lb Counterweight - Fully Extended Outriggers - 360° Rotation (All Capacities Are Listed In Pounds)												
Radius (ft)	Main Boom + 9.5 ft Manual Offset Fly (0°, 15°, 30°, 45° Offset)											Radius (ft)
	Boom Length (ft)											
	38.3	49-50.5	60-63	73.8-76.1	85-89.5	99.4-100	110-115	125-126.3	137.2-140.2	150-152.41	164.1	
10	41,100	42,200	47,700									10
12	40,100	41,300	42,100	47,600								12
15	38,800	40,100	41,000	41,600	47,600							15
20	37,000	38,400	39,400	40,200	40,700	40,700	40,000					20
25	35,700	37,000	38,100	38,900	39,600	39,700	39,800	30,700	20,700			25
30	34,400	36,100	37,000	37,900	38,600	38,800	39,800	30,700	25,700	18,600		30
35	34,200	34,700	36,200	37,000	37,700	38,000	39,100	30,700	25,700	20,500	16,000	35
40	34,200	34,400	35,100	36,300	37,000	36,000	38,300	30,700	25,700	20,500	16,000	40
45		34,100	34,400	35,400	36,400	34,200	37,100	30,700	25,700	20,500	16,000	45
50		34,100	34,300	34,400	35,400	32,500	35,200	29,700	25,700	20,500	16,000	50
55			31,900	31,500	30,400	31,000	33,100	25,500	25,700	20,500	16,000	55
60			27,900	27,400	28,000	27,300	33,400	25,600	23,800	20,500	16,000	60
65			24,600	25,100	24,900	24,000	26,500	23,900	22,100	20,500	16,000	65
70				22,700	22,100	21,900	23,100	21,100	20,700	19,300	16,000	70
75				20,300	19,700	19,800	20,800	18,700	18,900	18,000	16,000	75
80					17,700	17,700	19,300	16,800	16,900	16,600	16,000	80
85					16,200	16,00	17,300	15,700	15,300	15,700	15,200	85
90					14,100	15,100	15,700	14,400	14,300	14,300	13,700	90
95						13,700	14,800	13,200	13,400	12,900	12,300	95
100						12,500	13,500	12,500	12,300	11,700	11,100	100
105							12,300	11,600	11,200	10,600	10,000	105
110							11,200	10,600	10,200	9,600	9,000	110
115							10,300	9,700	9,400	8,700	8,100	115
120							8,600	8,900	8,600	7,900	7,300	120
125								8,200	7,800	7,200	6,600	125
130									7,200	6,500	5,900	130
135									6,600	5,900	5,300	135
140									4,900	5,400	4,800	140
145										4,800	4,200	145
150										4,400	3,800	150
155											3,300	155
160											2,900	160

This information is not for crane operation. Operator must refer to the in- cab information for crane operation. Rated lifting capacities shown on fully extended outriggers do not exceed 85% of the tipping loads and on tires do not exceed 75% of the tipping loads.

16,000 lb Counterweight - Fully Extended Outriggers - 360° Rotation (All Capacities Are Listed In Pounds)									
164.1 ft Main Boom Length									
Radius (ft)	35 ft Manual Offset Fly				58 ft Manual Offset Fly				Radius (ft)
	0°	15°	30°	45°	0°	15°	30°	45°	
40	11,000								40
45	11,000								45
50	11,000				7,400				50
55	11,000	11,500			7,400				55
60	11,000	11,500			7,400				60
65	11,000	11,500	11,300		7,400	7,800			65
70	11,000	11,500	11,100	10,100	7,400	7,600			70
75	10,000	11,000	11,000	9,900	7,400	7,400			75
80	8,600	9,500	10,300	9,700	7,400	7,300	6,200		80
85	7,300	8,200	8,900	9,500	7,400	7,100	6,100		85
90	6,300	7,100	7,700	8,300	6,900	7,000	6,000	5,300	90
95	5,300	6,100	6,700	7,200	5,900	6,900	5,900	5,200	95
100	4,500	5,200	5,700	6,200	5,100	6,200	5,800	5,100	100
105	3,800	4,400	4,900	5,300	4,300	5,400	5,700	5,100	105
110	3,100	3,700	4,100	4,500	3,700	4,600	5,500	5,000	110
115	2,500	3,000	3,500	3,800	3,100	4,000	4,800	5,000	115
120	1,900	2,400	2,800	3,100	2,500	3,400	4,100	4,700	120
125	1,500	1,900	2,300	2,500	2,000	2,800	3,500	4,000	125
130	1,000	1,400	1,800	2,000	1,600	2,300	2,900	3,400	130
135		1,000	1,300	1,500	1,100	1,800	2,400	2,800	135
140				1,000		1,400	1,900	2,300	140
145						1,000	1,500	1,800	145
150							1,100	1,400	150
155								900	155

This information is not for crane operation. Operator must refer to the in- cab information for crane operation. Rated lifting capacities shown on fully extended outriggers do not exceed 85% of the tipping loads and on tires do not exceed 75% of the tipping loads.

16,000 lb Counterweight - Fully Extended Outriggers - 360° Rotation (All Capacities Are Listed In Pounds)									
164.1 ft Main Boom Length									
Radius (ft)	74 ft Manual Offset Fly				90 ft Manual Offset Fly				Radius (ft)
	0°	15°	30°	45°	0°	15°	30°	45°	
50	5,300								50
55	5,300								55
60	5,300				4,000				60
65	5,300				4,000				65
70	5,300	5,300			4,000				70
75	5,300	5,200			4,000				75
80	5,300	5,100			4,000	4,100			80
85	5,300	4,900	4,400		4,000	4,000			85
90	5,300	4,800	4,300	3,900	4,000	3,900			90
95	5,300	4,700	4,200	3,800	4,000	3,800	3,500		95
100	5,200	4,600	4,100	3,700	4,000	3,700	3,300	3,100	100
105	4,400	4,500	4,000	3,600	4,000	3,500	3,200	3,000	105
110	3,700	4,300	3,900	3,600	3,700	3,400	3,100	3,000	110
115	3,100	4,000	3,800	3,500	3,100	3,300	3,100	2,900	115
120	2,600	3,400	3,700	3,400	2,600	3,200	3,000	2,800	120
125	2,000	2,900	3,600	3,400	2,000	2,900	2,900	2,700	125
130	1,600	2,400	3,000	3,300	1,600	2,400	2,800	2,600	130
135	1,200	1,900	2,500	3,000	1,200	1,900	2,600	2,600	135
140		1,400	2,000	2,400		1,500	2,100	2,500	140
145		1,000	1,600	2,000		1,100	1,600	2,000	145
150			1,200	1,500			1,200	1,600	150
155				1,100				1,200	155

This information is not for crane operation. Operator must refer to the in- cab information for crane operation. Rated lifting capacities shown on fully extended outriggers do not exceed 85% of the tipping loads and on tires do not exceed 75% of the tipping loads.

36,500 lb Counterweight - Fully Extended Outriggers - 360° Rotation (All Capacities Are Listed In Pounds)									
164.1 ft Main Boom Length									
Radius (ft)	35 ft Manual Offset Fly				58 ft Manual Offset Fly				Radius (ft)
	0°	15°	30°	45°	0°	15°	30°	45°	
40	11,000								40
45	11,000								45
50	11,000				7,400				50
55	11,000	11,500			7,400				55
60	11,000	11,500			7,400				60
65	11,000	11,500	11,300		7,400	7,800			65
70	11,000	11,500	11,100	10,100	7,400	7,600			70
75	11,000	11,500	11,000	9,900	7,400	7,400			75
80	11,000	11,500	10,800	9,700	7,400	7,300	6,200		80
85	11,000	11,500	10,700	9,600	7,400	7,100	6,100		85
90	11,000	11,500	10,500	9,500	7,400	7,000	6,000	5,300	90
95	10,100	10,800	10,300	9,300	7,400	6,900	5,900	5,200	95
100	9,000	9,700	10,100	9,200	7,400	6,700	5,800	5,100	100
105	8,000	8,700	9,200	9,100	7,400	6,600	5,700	5,100	105
110	7,200	7,800	8,200	8,600	7,400	6,400	5,600	5,000	110
115	6,400	6,900	7,400	7,700	7,000	6,300	5,500	5,000	115
120	5,700	6,200	6,600	6,800	6,200	6,200	5,400	4,900	120
125	5,000	5,500	5,900	6,100	5,600	6,100	5,300	4,900	125
130	4,500	4,900	5,200	5,400	5,000	5,700	5,300	4,800	130
135	3,900	4,300	4,600	4,800	4,400	5,100	5,200	4,800	135
140	3,400	3,800	4,000	4,200	3,900	4,600	5,100	4,800	140
145	2,900	3,300	3,500	3,600	3,500	4,000	4,500	4,700	145
150	2,500	2,800	3,000	3,100	3,000	3,600	4,000	4,300	150
155	2,100	2,400	2,600	2,600	2,600	3,100	3,500	3,800	155
160	1,700	2,000	2,100		2,200	2,700	3,100	3,300	160
165	1,300	1,600	1,700		1,900	2,300	2,700	2,800	165
170	1,000	1,200	1,300		1,500	2,000	2,300	2,400	170
175			900		1,200	1,600	1,900	2,000	175
180					900	1,300	1,500		180
185						900	1,100		185

This information is not for crane operation. Operator must refer to the in- cab information for crane operation. Rated lifting capacities shown on fully extended outriggers do not exceed 85% of the tipping loads and on tires do not exceed 75% of the tipping loads.

36,500 lb Counterweight - Fully Extended Outriggers - 360° Rotation (All Capacities Are Listed In Pounds)									
164.1 ft Main Boom Length									
Radius (ft)	74 ft Manual Offset Fly				90 ft Manual Offset Fly				Radius (ft)
	0°	15°	30°	45°	0°	15°	30°	45°	
50	5,300								50
55	5,300								55
60	5,300				4,000				60
65	5,300				4,000				65
70	5,300	5,300			4,000				70
75	5,300	5,200			4,000				75
80	5,300	5,100			4,000	4,100			80
85	5,300	4,900	4,400		4,000	4,000			85
90	5,300	4,800	4,300	3,900	4,000	3,900			90
95	5,300	4,700	4,200	3,800	4,000	3,800	3,500		95
100	5,300	4,600	4,100	3,700	4,000	3,700	3,300	3,100	100
105	5,200	4,500	4,000	3,600	4,000	3,500	3,200	3,000	105
110	5,000	4,300	3,900	3,600	3,900	3,400	3,100	3,000	110
115	4,900	4,200	3,800	3,500	3,800	3,300	3,100	2,900	115
120	4,800	4,100	3,700	3,400	3,600	3,200	3,000	2,800	120
125	4,600	4,000	3,600	3,400	3,500	3,100	2,900	2,700	125
130	4,500	3,900	3,500	3,300	3,400	3,000	2,800	2,600	130
135	4,400	3,800	3,500	3,300	3,300	2,900	2,700	2,600	135
140	3,900	3,700	3,400	3,200	3,200	2,800	2,600	2,500	140
145	3,500	3,700	3,300	3,200	3,100	2,800	2,500	2,400	145
150	3,000	3,600	3,300	3,100	3,000	2,700	2,500	2,400	150
155	2,600	3,200	3,200	3,100	2,600	2,600	2,400	2,300	155
160	2,200	2,800	3,100	3,000	2,200	2,500	2,300	2,300	160
165	1,900	2,400	2,800	3,000	1,800	2,400	2,300	2,200	165
170	1,500	2,000	2,400	2,600	1,500	2,000	2,200	2,100	170
175	1,200	1,700	2,000	2,200	1,100	1,700	2,000	2,100	175
180		1,300	1,600	1,800		1,300	1,700	1,900	180
185		1,000	1,300	1,400		900	1,300	1,500	185
190			900	1,000			900	1,100	190

This information is not for crane operation. Operator must refer to the in- cab information for crane operation. Rated lifting capacities shown on fully extended outriggers do not exceed 85% of the tipping loads and on tires do not exceed 75% of the tipping loads.

49,100 lb Counterweight - Fully Extended Outriggers - 360° Rotation (All Capacities Are Listed In Pounds)									
164.1 ft Main Boom Length									
Radius (ft)	35 ft Manual Offset Fly				58 ft Manual Offset Fly				Radius (ft)
	0°	15°	30°	45°	0°	15°	30°	45°	
40	11,000								40
45	11,000								45
50	11,000				7,400				50
55	11,000	11,500			7,400				55
60	11,000	11,500			7,400				60
65	11,000	11,500	11,300		7,400	7,800			65
70	11,000	11,500	11,100	10,100	7,400	7,600			70
75	11,000	11,500	11,000	9,900	7,400	7,400			75
80	11,000	11,500	10,800	9,700	7,400	7,300	6,200		80
85	11,000	11,500	10,700	9,600	7,400	7,100	6,100		85
90	11,000	11,500	10,500	9,500	7,400	7,000	6,000	5,300	90
95	11,000	11,500	10,300	9,300	7,400	6,900	5,900	5,200	95
100	11,000	11,300	10,100	9,200	7,400	6,700	5,800	5,100	100
105	10,500	10,900	9,900	9,100	7,400	6,600	5,700	5,100	105
110	9,500	10,100	9,700	9,000	7,400	6,400	5,600	5,000	110
115	8,600	9,200	9,400	8,900	7,400	6,300	5,500	5,000	115
120	7,800	8,300	8,700	8,800	7,300	6,200	5,400	4,900	120
125	7,100	7,500	7,900	8,100	7,100	6,100	5,300	4,900	125
130	6,400	6,800	7,100	7,300	6,900	5,900	5,300	4,800	130
135	5,800	6,200	6,500	6,600	6,300	5,800	5,200	4,800	135
140	5,200	5,600	5,800	6,000	5,700	5,700	5,100	4,800	140
145	4,700	5,000	5,200	5,300	5,200	5,600	5,000	4,700	145
150	4,200	4,500	4,700	4,800	4,700	5,200	5,000	4,700	150
155	3,700	4,000	4,200	4,200	4,200	4,700	4,900	4,700	155
160	3,300	3,500	3,700		3,800	4,300	4,600	4,600	160
165	2,900	3,100	3,200		3,400	3,800	4,200	4,300	165
170	2,500	2,700	2,800		3,000	3,400	3,700	3,900	170
175	2,100	2,300	2,400		2,600	3,000	3,300	3,400	175
180	1,700	1,900			2,300	2,700	2,900	3,000	180
185	1,400	1,500			1,900	2,300	2,500		185
190					1,600	1,900	2,100		190
195					1,300	1,600	1,700		195
200					1,000	1,200	1,300		200
205						900			205

This information is not for crane operation. Operator must refer to the in- cab information for crane operation. Rated lifting capacities shown on fully extended outriggers do not exceed 85% of the tipping loads and on tires do not exceed 75% of the tipping loads.

49,100 lb Counterweight - Fully Extended Outriggers - 360° Rotation (All Capacities Are Listed In Pounds)									
164.1 ft Main Boom Length									
Radius (ft)	74 ft Manual Offset Fly				90 ft Manual Offset Fly				Radius (ft)
	0°	15°	30°	45°	0°	15°	30°	45°	
50	5,300								50
55	5,300								55
60	5,300				4,000				60
65	5,300				4,000				65
70	5,300	5,300			4,000				70
75	5,300	5,200			4,000				75
80	5,300	5,100			4,000	4,100			80
85	5,300	4,900	4,400		4,000	4,000			85
90	5,300	4,800	4,300	3,900	4,000	3,900			90
95	5,300	4,700	4,200	3,800	4,000	3,800	3,500		95
100	5,300	4,600	4,100	3,700	4,000	3,700	3,300	3,100	100
105	5,200	4,500	4,000	3,600	4,000	3,500	3,200	3,000	105
110	5,000	4,300	3,900	3,600	3,900	3,400	3,100	3,000	110
115	4,900	4,200	3,800	3,500	3,800	3,300	3,100	2,900	115
120	4,800	4,100	3,700	3,400	3,600	3,200	3,000	2,800	120
125	4,600	4,000	3,600	3,400	3,500	3,100	2,900	2,700	125
130	4,500	3,900	3,500	3,300	3,400	3,000	2,800	2,600	130
135	4,400	3,800	3,500	3,300	3,300	2,900	2,700	2,600	135
140	4,300	3,700	3,400	3,200	3,200	2,800	2,600	2,500	140
145	4,200	3,700	3,300	3,200	3,100	2,800	2,500	2,400	145
150	4,100	3,600	3,300	3,100	3,000	2,700	2,500	2,400	150
155	4,000	3,500	3,200	3,100	2,900	2,600	2,400	2,300	155
160	3,800	3,400	3,100	3,000	2,800	2,500	2,300	2,300	160
165	3,400	3,300	3,100	3,000	2,700	2,400	2,300	2,200	165
170	3,000	3,300	3,000	3,000	2,600	2,400	2,200	2,100	170
175	2,600	3,100	3,000	2,900	2,500	2,300	2,200	2,100	175
180	2,300	2,700	3,000	2,900	2,200	2,200	2,100	2,100	180
185	1,900	2,300	2,600	2,700	1,900	2,200	2,000	2,000	185
190	1,600	2,000	2,200	2,300	1,500	2,000	2,000	2,000	190
195	1,300	1,600	1,900		1,200	1,600	1,900	1,900	195
200	1,000	1,300	1,500		900	1,300	1,600	1,600	200
205		1,000	1,100			1,000	1,200	1,300	205
210							900		210

This information is not for crane operation. Operator must refer to the in- cab information for crane operation. Rated lifting capacities shown on fully extended outriggers do not exceed 85% of the tipping loads and on tires do not exceed 75% of the tipping loads.

# Main Boom Lift Capacity Charts - Metric 75%ISO

7.2t Counterweight - Fully Extended Outriggers - 360° Rotation (All Capacities Are Listed In Kilograms)												
Radius (m)	Boom Length (m)											Radius (m)
	11.67	15.24-15.38	18.29-19.21	22.51-23.18	25.91-27.28	30.31-30.48	33.53-35.05	38.10-38.51	41.82-42.75	45.72-46.45	50.02	
3.0	77 200	73 400	62 400									3.0
3.5	68 100	68 100	62 400									3.5
4.0	59 750	60 150	59 500	54 600								4.0
4.5	53 000	53 700	53 350	52 350	41 500							4.5
5.0	47 500	48 350	48 200	47 450	41 500							5.0
6.0	38 950	40 000	40 100	39 700	38 850	29 850	22 850					6.0
7.0	31 950	33 550	34 000	33 800	33 250	29 850	22 850					7.0
8.0	24 500	26 100	27 150	27 300	27 050	26 600	22 850	17 600	11 550			8.0
9.0	19 500	21 400	22 050	22 200	22 000	21 600	21 150	17 600	14 000	11 050		9.0
10.0		17 700	18 450	18 600	18 700	18 500	18 350	17 600	14 000	11 050		10.0
12.0		12 800	13 550	13 800	14 200	14 100	13 950	13 750	12 900	11 050	8 900	12.0
14.0			10 600	11 050	11 050	11 250	11 250	11 050	10 900	10 200	8 900	14.0
16.0			8 400	8 850	9 100	9 100	9 050	8 900	8 750	8 450	8 200	16.0
18.0				7 200	7 450	7 500	7 450	7 300	7 150	6 900	6 650	18.0
20.0				6 000	6 250	6 250	6 250	6 050	5 950	5 650	5 400	20.0
22.0					5 200	5 250	5 250	5 050	4 950	4 650	4 350	22.0
24.0					4 400	4 400	4 450	4 250	4 100	3 800	3 550	24.0
26.0						3 700	3 750	3 550	3 400	3 100	2 850	26.0
28.0						3 100	3 150	2 950	2 850	2 550	2 250	28.0
30.0							2 600	2 450	2 350	2 050	1 800	30.0
32.0							1 350	2 000	1 900	1 650	1 350	32.0
34.0								1 650	1 500	1 250	1 000	34.0
36.0								900	1 200	900	700	36.0
38.0									900	650	400	38.0
40.0										400		40.0

This information is not for crane operation. Operator must refer to the in- cab information for crane operation. Rated lifting capacities shown on fully extended outriggers do not exceed 85% of the tipping loads and on tires do not exceed 75% of the tipping loads.

9t Counterweight - Fully Extended Outriggers - 360° Rotation (All Capacities Are Listed In Kilograms)												
Radius (m)	Boom Length (m)											Radius (m)
	11.67	15.24-15.38	18.29-19.21	22.51-23.18	25.91-27.28	30.31-30.48	33.53-35.05	38.10-38.51	41.82-42.75	45.72-46.45	50.02	
3.0	77 400	73 400	62 400									3.0
3.5	69 650	68 300	62 400									3.5
4.0	61 150	61 500	60 450	54 600								4.0
4.5	54 300	54 900	54 550	53 500	41 500							4.5
5.0	48 650	49 450	49 300	48 550	41 500							5.0
6.0	39 950	40 950	41 050	40 600	39 750	29 850	22 850					6.0
7.0	33 550	34 700	34 950	34 650	34 000	29 850	22 850					7.0
8.0	26 300	27 900	28 300	29 050	28 850	28 400	22 850	17 600	11 550			8.0
9.0	21 000	22 850	23 550	23 700	23 500	23 050	22 600	17 600	14 000	11 050		9.0
10.0		19 000	19 700	19 850	19 650	19 800	19 000	17 600	14 000	11 050		10.0
12.0		13 800	14 550	14 700	14 950	14 950	14 900	14 700	13 950	11 050	8 900	12.0
14.0			11 250	11 900	11 900	11 800	11 750	11 850	11 550	10 900	8 900	14.0
16.0			9 100	9 550	9 600	9 800	9 750	9 550	9 450	9 150	8 900	16.0
18.0				7 850	8 050	8 100	8 100	7 900	7 750	7 450	7 200	18.0
20.0				6 550	6 800	6 850	6 850	6 650	6 500	6 250	6 000	20.0
22.0					5 750	5 800	5 800	5 600	5 500	5 200	4 950	22.0
24.0					4 900	4 950	4 950	4 750	4 650	4 350	4 050	24.0
26.0						4 200	4 200	4 050	3 900	3 600	3 300	26.0
28.0							3 550	3 550	3 400	3 250	2 700	28.0
30.0								3 050	2 850	2 750	2 200	30.0
32.0								1 750	2 400	2 250	1 750	32.0
34.0									2 000	1 850	1 350	34.0
36.0									1 250	1 500	1 000	36.0
38.0										1 200	700	38.0
40.0											650	40.0

This information is not for crane operation. Operator must refer to the in- cab information for crane operation. Rated lifting capacities shown on fully extended outriggers do not exceed 85% of the tipping loads and on tires do not exceed 75% of the tipping loads.

16.4t Counterweight - Fully Extended Outriggers - 360° Rotation (All Capacities Are Listed In Kilograms)												
Radius (m)	Boom Length (m)											Radius (m)
	11.67	15.24-15.38	18.29-19.21	22.51-23.18	25.91-27.28	30.31-30.48	33.53-35.05	38.10-38.51	41.82-42.75	45.72-46.45	50.02	
3.0	78 250	73 400	62 400									3.0
3.5	72 000	68 300	62 400									3.5
4.0	66 500	63 800	60 450	54 600								4.0
4.5	59 400	59 900	57 150	54 600	41 500							4.5
5.0	53 350	54 050	53 750	52 800	41 500							5.0
6.0	43 950	44 900	44 900	44 350	41 500	29 850	22 850					6.0
7.0	37 000	38 100	38 300	37 950	37 200	29 850	22 850					7.0
8.0	31 750	32 900	33 200	32 950	32 350	29 850	22 850	17 600	11 550			8.0
9.0	27 200	28 750	29 100	28 950	29 350	28 800	22 850	17 600	14 000	11 050		9.0
10.0		24 000	24 650	25 150	24 950	24 500	22 100	17 600	14 000	11 050		10.0
12.0		17 950	18 700	18 850	18 650	18 250	17 900	17 550	14 000	11 050	8 900	12.0
14.0			14 600	14 800	14 700	14 700	14 600	14 350	14 000	11 050	8 900	14.0
16.0			11 750	12 000	12 400	12 250	12 200	12 050	11 750	11 050	8 900	16.0
18.0				10 200	10 350	10 300	10 150	10 350	10 250	9 950	8 900	18.0
20.0				8 700	8 750	8 700	8 750	8 800	8 650	8 400	8 150	20.0
22.0					7 500	7 700	7 750	7 550	7 400	7 150	6 950	22.0
24.0					6 500	6 700	6 750	6 600	6 450	6 200	5 950	24.0
26.0						5 850	5 900	5 750	5 600	5 350	5 150	26.0
28.0						5 150	5 150	5 000	4 900	4 650	4 400	28.0
30.0							4 550	4 400	4 250	4 000	3 750	30.0
32.0							3 200	3 850	3 700	3 450	3 200	32.0
34.0								3 350	3 200	2 950	2 700	34.0
36.0								2 550	2 800	2 550	2 300	36.0
38.0									2 400	2 150	1 900	38.0
40.0									1 550	1 850	1 600	40.0
42.0										1 550	1 300	42.0
44.0										750	1000	44.0
46.0											800	46.0

This information is not for crane operation. Operator must refer to the in- cab information for crane operation. Rated lifting capacities shown on fully extended outriggers do not exceed 85% of the tipping loads and on tires do not exceed 75% of the tipping loads.

<b>22.2t Counterweight - Fully Extended Outriggers - 360° Rotation</b> (All Capacities Are Listed In Kilograms)												
Radius (m)	Boom Length (m)											Radius (m)
	11.67	15.24-15.38	18.29-19.21	22.51-23.18	25.91-27.28	30.31-30.48	33.53-35.05	38.10-38.51	41.82-42.75	45.72-46.45	50.02	
2.1	110 000*											2.1
3.0	78 250	73 400	62 400									3.0
3.5	72 600	68 300	62 400									3.5
4.0	67 100	63 800	60 450	54 600								4.0
4.5	62 300	59 900	57 150	54 600	41 500							4.5
5.0	56 950	56 350	54 200	54 600	41 500							5.0
6.0	47 000	47 900	47 850	47 200	41 500	29 850	22 850					6.0
7.0	39 650	40 750	40 850	40 450	39 550	29 850	22 850					7.0
8.0	34 050	35 200	35 500	35 200	34 550	29 850	22 850	17 600	11 550			8.0
9.0	29 650	30 850	31 150	30 950	30 400	29 850	22 850	17 600	14 000	11 050		9.0
10.0		27 300	27 700	27 550	28 000	27 500	22 100	17 600	14 000	11 050		10.0
12.0		20 850	21 800	21 950	21 800	21 450	19 250	17 550	14 000	11 050	8 900	12.0
14.0			17 200	17 400	17 200	16 850	16 500	15 850	14 000	11 050	8 900	14.0
16.0			13 950	14 200	14 050	14 150	14 000	13 750	12 900	11 050	8 900	16.0
18.0				11 800	11 900	12 100	11 700	11 450	11 600	10 950	8 900	18.0
20.0				10 000	10 450	10 300	10 200	10 050	9 800	10 050	8 900	20.0
22.0					9 000	8 850	8 850	8 800	8 850	8 650	8 400	22.0
24.0					7 850	7 750	7 650	7 900	7 750	7 500	7 250	24.0
26.0						6 850	6 800	7 000	6 850	6 600	6 400	26.0
28.0						6 300	6 300	6 150	6 050	5 800	5 600	28.0
30.0							5 600	5 450	5 350	5 150	4 900	30.0
32.0							4 250	4 850	4 750	4 500	4 250	32.0
34.0								4 300	4 200	3 950	3 700	34.0
36.0								3 450	3 700	3 450	3 200	36.0
38.0									3 300	3 050	2 800	38.0
40.0									2 350	2 650	2 400	40.0
42.0										2 300	2 050	42.0
44.0										1 500	1 750	44.0
46.0											1 500	46.0

\* Boom centered over rear and special equipment

This information is not for crane operation. Operator must refer to the in-cab information for crane operation. Rated lifting capacities shown on fully extended outriggers do not exceed 85% of the tipping loads and on tires do not exceed 75% of the tipping loads.

# Manual Offset Fly Lift Capacity Charts - Metric 75%ISO

22.2t Counterweight - Fully Extended Outriggers - 360° Rotation (All Capacities Are Listed In Kilograms)												
Radius (m)	Main Boom +2.9m Manual Offset Fly (0°, 15°, 30°, 45° Offsets)											Radius (m)
	Boom Length (m)											
	11.67	15.24- 15.3	18.29- 19.2	22.51- 23.1	25.91- 27.2	30.31- 30.4	33.53- 35.0	38.10- 38.5	41.82- 42.7	45.72- 46.4	50.02	
3.0	18 700	19 200	21 650									3.0
3.5	18 300	18 850	21 650	21 600								3.5
4.0	17 950	18 500	18 900	21 600								4.0
4.5	17 650	18 200	18 600	18 900	21 600							4.5
5.0	17 350	17 950	18 350	18 700	18 850	18 850						5.0
6.0	16 850	17 450	17 900	18 250	18 500	18 500	18 100					6.0
7.0	16 450	17 000	17 500	17 900	18 150	18 200	18 100	13 900				7.0
8.0	15 950	16 700	17 150	17 550	17 850	17 900	18 000	13 900	9 400			8.0
9.0	15 600	16 400	16 850	17 250	17 550	17 650	17 750	13 900	11 650	8 450		9.0
10.0	15 600	16 000	16 600	16 950	17 300	17 400	17 550	13 900	11 650	9 300	7 250	10.0
12.0	15 600	15 600	16 000	16 500	16 800	16 450	16 950	13 900	11 650	9 300	7 250	12.0
14.0		15 450	15 600	15 950	16 250	15 400	15 850	13 900	11 650	9 300	7 250	14.0
16.0		10 850	13 750	13 550	13 650	13 550	13 150	12 950	11 650	9 300	7 250	16.0
18.0			11 450	11 800	11 600	11 450	11 100	11 150	10 850	9 300	7 250	18.0
20.0				10 050	9 800	9 800	9 650	9 400	9 450	9 250	7 250	20.0
22.0				8 650	8 600	8 400	8 300	8 400	8 050	8 250	7 250	22.0
24.0					7 450	7 500	7 450	7 250	7 400	7 150	6 950	24.0
26.0					6 600	6 600	6 550	6 650	6 550	6 300	6 050	26.0
28.0					4 800	5 900	5 750	5 900	5 750	5 500	5 200	28.0
30.0						5 200	5 200	5 200	5 050	4 750	4 500	30.0
32.0							4 850	4 600	4 450	4 150	3 850	32.0
34.0							4 300	4 050	3 900	3 600	3 300	34.0
36.0								3 600	3 400	3 150	2 850	36.0
38.0								3 200	3 000	2 700	2 450	38.0
40.0									2 650	2 350	2 050	40.0
42.0									2 300	2 000	1 750	42.0
44.0										1 700	1 450	44.0
46.0										1 450	1 150	46.0
48.0											900	48.0

This information is not for crane operation. Operator must refer to the in- cab information for crane operation. Rated lifting capacities shown on fully extended outriggers do not exceed 85% of the tipping loads and on tires do not exceed 75% of the tipping loads.

<b>7.2t Counterweight - Fully Extended Outriggers - 360° Rotation</b> (All Capacities Are Listed In Pounds)									
<b>50.2m Main Boom Length</b>									
Radius (m)	10.7m Manual Offset Fly				17.7m Manual Offset Fly				Radius (m)
	0°	15°	30°	45°	0°	15°	30°	45°	
12.0	5 000								12.0
14.0	5 000								14.0
16.0	5 000	5 200			3 400				16.0
18.0	5 000	5 200			3 400				18.0
20.0	5 000	5 200	5 100		3 400	3 500			20.0
22.0	4 250	4 750	5 000	4 550	3 400	3 400			22.0
24.0	3 400	3 850	4 250	4 450	3 400	3 300	2 850		24.0
26.0	2 700	3 100	3 450	3 700	3 000	3 250	2 750		26.0
28.0	2 100	2 500	2 800	3 000	2 400	3 000	2 700	2 400	28.0
30.0	1 650	1 950	2 200	2 400	1 900	2 450	2 650	2 350	30.0
32.0	1 200	1 500	1 750	1 900	1 500	1 950	2 400	2 300	32.0
34.0	850	1 100	1 300	1 450	1 100	1 550	1 950	2 250	34.0
36.0	500	750	950	1 100	800	1 200	1 550	1 800	36.0
38.0			600	750	500	850	1 200	1 400	38.0
40.0						550	850	1 050	40.0
42.0							600	750	42.0

<b>7.2t Counterweight - Fully Extended Outriggers - 360° Rotation</b> (All Capacities Are Listed In Pounds)									
<b>50.2m Main Boom Length</b>									
Radius (m)	33.7m Manual Offset Fly				49.7m Manual Offset Fly				Radius (m)
	0°	15°	30°	45°	0°	15°	30°	45°	
16.0	2 400				1 800				16.0
18.0	2 400				1 800				18.0
20.0	2 400				1 800				20.0
22.0	2 400	2 400			1 800	1 900			22.0
24.07.2	2 400	2 300			1 800	1 900			24.0
26.0	2 400	2 250	2 000		1 800	1 800	1 650		26.0
28.0	2 400	2 150	1 900	1 750	1 800	1 750	1 600		28.0
30.0	1 950	2 100	1 850	1 700	1 800	1 650	1 550	1 450	30.0
32.0	1 500	2 000	1 800	1 650	1 500	1 600	1 450	1 400	32.0
34.0	1 150	1 600	1 750	1 600	1 150	1 550	1 400	1 350	34.0
36.0	800	1 200	1 550	1 550	800	1 200	1 350	1 300	36.0
38.0	500	900	1 200	1 450	500	900	1 250	1 250	38.0
40.0		600	900	1 150		600	900	1 150	40.0
42.0			600	800			650	850	42.0
44.0				550				550	44.0

This information is not for crane operation. Operator must refer to the in- cab information for crane operation. Rated lifting capacities shown on fully extended outriggers do not exceed 85% of the tipping loads and on tires do not exceed 75% of the tipping loads.

16.4t Counterweight - Fully Extended Outriggers - 360° Rotation (All Capacities Are Listed In Pounds)									
50.2m Main Boom Length									
Radius (m)	10.7m Manual Offset Fly				17.7m Manual Offset Fly				Radius (m)
	0°	15°	30°	45°	0°	15°	30°	45°	
12.0	5 000								12.0
14.0	5 000								14.0
16.0	5 000	5 200			3 400				16.0
18.0	5 000	5 200			3 400				18.0
20.0	5 000	5 200	5 100		3 400	3 500			20.0
22.0	5 000	5 200	5 000	4 550	3 400	3 400			22.0
24.0	5 000	5 200	4 900	4 450	3 400	3 300	2 850		24.0
26.0	4 950	5 200	4 850	4 350	3 400	3 250	2 750		26.0
28.0	4 200	4 550	4 750	4 250	3 400	3 150	2 700	2 400	28.0
30.0	3 600	3 900	4 150	4 200	3 400	3 050	2 650	2 350	30.0
32.0	3 050	3 300	3 550	3 750	3 300	3 000	2 600	2 300	32.0
34.0	2 550	2 800	3 050	3 200	2 800	2 900	2 500	2 250	34.0
36.0	2 150	2 400	2 550	2 700	2 400	2 800	2 450	2 200	36.0
38.0	1 800	2 000	2 150	2 250	2 000	2 400	2 400	2 200	38.0
40.0	1 450	1 650	1 800	1 900	1 700	2 000	2 300	2 200	40.0
42.0	1 150	1 350	1 450	1 550	1 400	1 700	1 950	2 100	42.0
44.0	900	1 050	1 150	1 200	1 100	1 400	1 650	1 800	44.0
46.0	650	800	900	900	900	1 150	1 350	1 450	46.0
48.0		550	650		650	900	1 050	1 200	48.0
50.0						650	800	900	50.0
52.0							600	650	52.0

16.4t Counterweight - Fully Extended Outriggers - 360° Rotation (All Capacities Are Listed In Pounds)									
50.2m Main Boom Length									
Radius (m)	33.7m Manual Offset Fly				49.7m Manual Offset Fly				Radius (m)
	0°	15°	30°	45°	0°	15°	30°	45°	
16.0	2 400				1 800				16.0
18.0	2 400				1 800				18.0
20.0	2 400				1 800				20.0
22.0	2 400	2 400			1 800	1 900			22.0
24.0	2 400	2 300			1 800	1 900			24.0
26.0	2 400	2 250	2 000		1 800	1 800	1 650		26.0
28.0	2 400	2 150	1 900	1 750	1 800	1 750	1 600		28.0
30.0	2 400	2 100	1 850	1 700	1 800	1 650	1 550	1 450	30.0
32.0	2 350	2 000	1 800	1 650	1 800	1 600	1 450	1 400	32.0
34.0	2 250	1 950	1 750	1 600	1 750	1 550	1 400	1 350	34.0
36.0	2 200	1 900	1 700	1 550	1 650	1 500	1 350	1 300	36.0
38.0	2 050	1 800	1 650	1 550	1 600	1 400	1 300	1 250	38.0
40.0	1 700	1 750	1 600	1 500	1 550	1 350	1 250	1 200	40.0
42.0	1 400	1 700	1 550	1 450	1 400	1 300	1 200	1 150	42.0
44.0	1 150	1 400	1 500	1 450	1 100	1 250	1 150	1 100	44.0
46.0	900	1 150	1 350	1 400	850	1 150	1 100	1 050	46.0
48.0	650	900	1 100	1 250	650	900	1 050	1 050	48.0
50.0		700	850	950		700	900	1 000	50.0
52.0		500	650	750		500	650	750	52.0
54.0				500				550	54.0

This information is not for crane operation. Operator must refer to the in- cab information for crane operation. Rated lifting capacities shown on fully extended outriggers do not exceed 85% of the tipping loads and on tires do not exceed 75% of the tipping loads.

22.2t Counterweight - Fully Extended Outriggers - 360° Rotation (All Capacities Are Listed In Pounds)									
50.2m Main Boom Length									
Radius (m)	10.7m Manual Offset Fly				17.7m Manual Offset Fly				Radius (m)
	0°	15°	30°	45°	0°	15°	30°	45°	
12.0	5 000								12.0
14.0	5 000								14.0
16.0	5 000	5 200			3 400				16.0
18.0	5 000	5 200			3 400				18.0
20.0	5 000	5 200	5 100		3 400	3 500			20.0
22.0	5 000	5 200	5 000	4 550	3 400	3 400			22.0
24.0	5 000	5 200	4 900	4 450	3 400	3 300	2 850		24.0
26.0	5 000	5 200	4 850	4 350	3 400	3 250	2 750		26.0
28.0	5 000	5 200	4 750	4 250	3 400	3 150	2 700	2 400	28.0
30.0	4 700	5 050	4 600	4 200	3 400	3 050	2 650	2 350	30.0
32.0	4 100	4 350	4 500	4 150	3 400	3 000	2 600	2 300	32.0
34.0	3 550	3 800	4 000	4 050	3 400	2 900	2 500	2 250	34.0
36.0	3 050	3 300	3 500	3 600	3 300	2 800	2 450	2 250	36.0
38.0	2 650	2 850	3 000	3 150	2 900	2 750	2 400	2 200	38.0
40.0	2 250	2 450	2 600	2 700	2 500	2 700	2 350	2 200	40.0
42.0	1 950	2 100	2 250	2 300	2 150	2 450	2 350	2 150	42.0
44.0	1 650	1 800	1 900	1 950	1 850	2 150	2 300	2 150	44.0
46.0	1 350	1 500	1 600	1 600	1 600	1 850	2 050	2 100	46.0
48.0	1 100	1 250	1 300		1 350	1 550	1 750	1 850	48.0
50.0	900	1 000	1 050		1 100	1 300	1 450	1 550	50.0
52.0	650	750	800		900	1 100	1 200	1 300	52.0
54.0	500	550	600		700	850	1 000	1 000	54.0
56.0					500	650	750		56.0
58.0						500	550		58.0

22.2t Counterweight - Fully Extended Outriggers - 360° Rotation (All Capacities Are Listed In Pounds)									
50.2m Main Boom Length									
Radius (m)	33.7m Manual Offset Fly				49.7m Manual Offset Fly				Radius (m)
	0°	15°	30°	45°	0°	15°	30°	45°	
16.0	2 400				1 800				16.0
18.0	2 400				1 800				18.0
20.0	2 400				1 800				20.0
22.0	2 400	2 400			1 800	1 900			22.0
24.0	2 400	2 300			1 800	1 900			24.0
26.0	2 400	2 250	2 000		1 800	1 800	1 650		26.0
28.0	2 400	2 150	1 900	1 750	1 800	1 750	1 600		28.0
30.0	2 400	2 100	1 850	1 700	1 800	1 650	1 550	1 450	30.0
32.0	2 350	2 000	1 800	1 650	1 800	1 600	1 450	1 400	32.0
34.0	2 250	1 950	1 750	1 600	1 750	1 550	1 400	1 350	34.0
36.0	2 200	1 900	1 700	1 550	1 650	1 500	1 350	1 300	36.0
38.0	2 100	1 800	1 650	1 550	1 600	1 400	1 300	1 250	38.0
40.0	2 050	1 750	1 600	1 500	1 550	1 350	1 250	1 200	40.0
42.0	1 950	1 700	1 550	1 450	1 450	1 300	1 200	1 150	42.0
44.0	1 850	1 650	1 500	1 450	1 400	1 250	1 150	1 100	44.0
46.0	1 600	1 600	1 450	1 400	1 350	1 200	1 100	1 050	46.0
48.0	1 350	1 550	1 450	1 400	1 300	1 150	1 050	1 050	48.0
50.0	1 100	1 350	1 400	1 350	1 100	1 100	1 050	1 000	50.0
52.0	900	1 100	1 250	1 350	850	1 050	1 000	950	52.0
54.0	700	900	1 050	1 100	650	900	950	950	54.0
56.0	500	700	800	850	500	700	850	900	56.0
58.0		500	600	650		500	650	700	58.0
60.0								500	60.0

This information is not for crane operation. Operator must refer to the in- cab information for crane operation. Rated lifting capacities shown on fully extended outriggers do not exceed 85% of the tipping loads and on tires do not exceed 75% of the tipping loads.

# Main Boom Lift Capacity Charts - Metric 85%

7.2t Counterweight - Fully Extended Outriggers - 360° Rotation (All Capacities Are Listed In Kilograms)												
Radius (m)	Boom Length (m)											Radius (m)
	11.67	15.24-15.38	18.29-19.21	22.51-23.18	25.91-27.28	30.31-30.48	33.53-35.05	38.10-38.51	41.82-42.75	45.72-46.45	50.02	
3.0	77 200	73 400	62 400									3.0
3.5	68 100	68 100	62 400									3.5
4.0	59 750	60 150	59 500	54 600								4.0
4.5	53 000	53 700	53 350	52 350	41 500							4.5
5.0	47 500	48 350	48 200	47 450	41 500							5.0
6.0	38 950	40 000	40 100	39 700	38 850	29 850	22 850					6.0
7.0	32 700	33 850	34 100	33 800	33 250	29 850	22 850					7.0
8.0	27 800	29 100	29 450	30 000	29 650	29 100	22 850	17 600	11 550			8.0
9.0	22 100	23 900	25 000	25 200	24 950	24 450	22 850	17 600	14 000	11 050		9.0
10.0		20 100	20 900	21 100	20 850	20 400	19 950	17 600	14 000	11 050		10.0
12.0		14 500	15 350	15 550	15 650	15 800	15 300	15 050	14 000	11 050	8 900	12.0
14.0			11 800	12 350	12 550	12 450	12 250	12 500	11 700	11 050	8 900	14.0
16.0			9 550	10 050	10 100	10 300	10 300	10 100	9 900	9 600	8 900	16.0
18.0				8 200	8 400	8 500	8 500	8 250	8 100	7 800	7 450	18.0
20.0				6 800	7 100	7 100	7 100	6 900	6 750	6 400	6 150	20.0
22.0					5 900	5 950	5 950	5 750	5 600	5 300	5 050	22.0
24.0					5 000	5 050	5 050	4 850	4 700	4 400	4 150	24.0
26.0						4 300	4 300	4 100	3 950	3 700	3 400	26.0
28.0						3 650	3 650	3 500	3 350	3 050	2 800	28.0
30.0							3 100	2 950	2 850	2 550	2 300	30.0
32.0							1 850	2 500	2 400	2 100	1 850	32.0
34.0								2 100	2 000	1 700	1 450	34.0
36.0								1 350	1 650	1 350	1 100	36.0
38.0									1 300	1 050	800	38.0
40.0									500	800	550	40.0
32.0										550		32.0

This information is not for crane operation. Operator must refer to the in- cab information for crane operation. Rated lifting capacities shown on fully extended outriggers do not exceed 85% of the tipping loads and on tires do not exceed 75% of the tipping loads.

9t Counterweight - Fully Extended Outriggers - 360° Rotation (All Capacities Are Listed In Kilograms)												
Radius (m)	Boom Length (m)											Radius (m)
	11.67	15.24-15.38	18.29-19.21	22.51-23.18	25.91-27.28	30.31-30.48	33.53-35.05	38.10-38.51	41.82-42.75	45.72-46.45	50.02	
3.0	77 400	73 400	62 400									3.0
3.5	69 650	68 300	62 400									3.5
4.0	61 150	61 500	60 450	54 600								4.0
4.5	54 300	54 900	54 550	53 500	41 500							4.5
5.0	48 650	49 450	49 300	48 550	41 500							5.0
6.0	39 950	40 950	41 050	40 600	39 750	29 850	22 850					6.0
7.0	33 550	34 700	34 950	34 650	34 000	29 850	22 850					7.0
8.0	28 650	29 850	30 150	30 000	30 350	29 800	22 850	17 600	11 550			8.0
9.0	23 800	25 600	26 100	26 900	26 650	26 150	22 850	17 600	14 000	11 050		9.0
10.0		21 550	22 350	22 500	22 250	21 800	21 400	17 600	14 000	11 050		10.0
12.0		15 650	16 500	16 700	16 500	16 600	16 450	16 100	14 000	11 050	8 900	12.0
14.0			12 750	13 000	13 500	13 250	13 200	13 000	12 650	11 050	8 900	14.0
16.0			10 100	10 850	10 900	10 750	10 600	10 850	10 700	10 200	8 900	16.0
18.0				8 900	8 950	9 200	9 150	8 950	8 800	8 500	8 200	18.0
20.0				7 400	7 650	7 700	7 700	7 500	7 350	7 100	6 850	20.0
22.0					6 500	6 550	6 600	6 400	6 250	5 950	5 650	22.0
24.0					5 550	5 600	5 600	5 400	5 250	4 950	4 700	24.0
26.0						4 800	4 800	4 600	4 500	4 200	3 900	26.0
28.0						4 100	4 150	3 950	3 800	3 550	3 250	28.0
30.0							3 550	3 400	3 250	2 950	2 700	30.0
32.0							2 250	2 900	2 750	2 500	2 250	32.0
34.0								2 450	2 350	2 100	1 850	34.0
36.0								1 700	2 000	1 700	1 450	36.0
38.0									1 650	1 400	1 150	38.0
40.0									800	1 100	850	40.0
42.0										850	600	42.0

This information is not for crane operation. Operator must refer to the in- cab information for crane operation. Rated lifting capacities shown on fully extended outriggers do not exceed 85% of the tipping loads and on tires do not exceed 75% of the tipping loads.

**16.4t Counterweight - Fully Extended Outriggers - 360° Rotation**  
 (All Capacities Are Listed In Kilograms)

Radius (m)	Boom Length (m)										Radius (m)	
	11.67	15.24-15.38	18.29-19.21	22.51-23.18	25.91-27.28	30.31-30.48	33.53-35.05	38.10-38.51	41.82-42.75	45.72-46.45		50.02
3.0	78 250	73 400	62 400									3.0
3.5	72 000	68 300	62 400									3.5
4.0	66 500	63 800	60 450	54 600								4.0
4.5	59 400	59 900	57 150	54 600	41 500							4.5
5.0	53 350	54 050	53 750	52 800	41 500							5.0
6.0	43 950	44 900	44 900	44 350	41 500	29 850	22 850					6.0
7.0	37 000	38 100	38 300	37 950	37 200	29 850	22 850					7.0
8.0	31 750	32 900	33 200	32 950	32 350	29 850	22 850	17 600	11 550			8.0
9.0	27 550	28 800	29 100	28 950	29 350	28 800	22 850	17 600	14 000	11 050		9.0
10.0		25 450	25 800	26 400	26 150	25 700	22 100	17 600	14 000	11 050		10.0
12.0		20 050	21 200	21 400	21 150	20 750	19 250	17 550	14 000	11 050	8 900	12.0
14.0			16 550	16 800	16 600	16 200	15 800	15 850	14 000	11 050	8 900	14.0
16.0			13 350	13 600	13 450	13 600	13 400	13 150	12 850	11 050	8 900	16.0
18.0				11 250	11 450	11 550	11 150	11 050	11 000	10 750	8 900	18.0
20.0				9 450	9 950	9 800	9 750	9 550	9 650	9 500	8 900	20.0
22.0					8 500	8 450	8 350	8 550	8 400	8 100	7 850	22.0
24.0					7 350	7 400	7 350	7 400	7 250	7 050	6 800	24.0
26.0						6 650	6 700	6 500	6 400	6 100	5 850	26.0
28.0						5 850	5 850	5 700	5 600	5 300	5 050	28.0
30.0							5 150	5 000	4 900	4 650	4 400	30.0
32.0								3 800	4 400	4 300	4 050	32.0
34.0									3 900	3 800	3 550	34.0
36.0										3 350	3 100	36.0
38.0											2 950	38.0
40.0											2 300	40.0
42.0											2 000	42.0
44.0											2 250	44.0
46.0											1 250	46.0

This information is not for crane operation. Operator must refer to the in- cab information for crane operation. Rated lifting capacities shown on fully extended outriggers do not exceed 85% of the tipping loads and on tires do not exceed 75% of the tipping loads.

<b>22.2t Counterweight - Fully Extended Outriggers - 360° Rotation</b> (All Capacities Are Listed In Kilograms)												
Radius (m)	Boom Length (m)											Radius (m)
	11.67	15.24-15.38	18.29-19.21	22.51-23.18	25.91-27.28	30.31-30.48	33.53-35.05	38.10-38.51	41.82-42.75	45.72-46.45	50.02	
2.1	110 000*											2.1
3.0	78 850	73 400	62 400									3.0
3.5	72 600	68 300	62 400									3.5
4.0	67 100	63 800	60 450	54 600								4.0
4.5	62 300	59 900	57 150	54 600	41 500							4.5
5.0	56 950	56 350	54 200	54 600	41 500							5.0
6.0	47 000	47 900	47 850	47 200	41 500	29 850	22 850					6.0
7.0	39 650	40 750	40 850	40 450	39 550	29 850	22 850					7.0
8.0	34 050	35 200	35 500	35 200	34 550	29 850	22 850	17 600	11 550			8.0
9.0	29 650	30 850	31 150	30 950	30 400	29 850	22 850	17 600	14 000	11 050		9.0
10.0		27 300	27 700	27 550	28 000	27 500	22 100	17 600	14 000	11 050		10.0
12.0		21 900	22 350	22 950	22 750	22 350	19 250	17 550	14 000	11 050	8 900	12.0
14.0			18 950	19 150	19 000	18 600	16 950	15 850	14 000	11 050	8 900	14.0
16.0			15 800	16 050	15 900	15 500	15 050	14 550	12 900	11 050	8 900	16.0
18.0				13 400	13 300	13 150	13 250	12 950	11 800	10 950	8 900	18.0
20.0				11 350	11 200	11 650	11 200	10 950	10 800	10 200	8 900	20.0
22.0					9 850	10 050	9 650	9 350	9 500	9 500	8 900	22.0
24.0					8 900	8 700	8 700	8 450	8 250	8 500	8 200	24.0
26.0						7 650	7 600	7 550	7 500	7 450	7 150	26.0
28.0						6 800	6 700	7 000	6 900	6 600	6 350	28.0
30.0							5 950	6 200	6 100	5 850	5 600	30.0
32.0							4 900	5 550	5 400	5 150	4 900	32.0
34.0								4 950	4 850	4 550	4 350	34.0
36.0								4 050	4 300	4 050	3 850	36.0
38.0									3 850	3 600	3 350	38.0
40.0									2 900	3 200	2 950	40.0
42.0										2 850	2 600	42.0
44.0										2 050	2 300	44.0
46.0											2 000	46.0

\* Boom centered over rear and special equipment

This information is not for crane operation. Operator must refer to the in-cab information for crane operation. Rated lifting capacities shown on fully extended outriggers do not exceed 85% of the tipping loads and on tires do not exceed 75% of the tipping loads.

# Manual Offset Fly Lift Capacity Charts - Metric 85%

22.2t Counterweight - Fully Extended Outriggers - 360° Rotation (All Capacities Are Listed In Kilograms)												
Radius (m)	Main Boom +2.9m Manual Offset Fly (0°, 15°, 30°, 45° Offsets)											Radius (m)
	Boom Length (m)											
	11.67	15.24- 15.3	18.29- 19.2	22.51- 23.1	25.91- 27.2	30.31- 30.4	33.53- 35.0	38.10- 38.5	41.82- 42.7	45.72- 46.4	50.02	
3.0	18 700	19 200	21 650									3.0
3.5	18 300	18 850	21 650	21 600								3.5
4.0	17 950	18 500	18 900	21 600								4.0
4.5	17 650	18 200	18 600	18 900	21 600							4.5
5.0	17 350	17 950	18 350	18 700	18 850	18 850						5.0
6.0	16 850	17 450	17 900	18 250	18 500	18 500	18 100					6.0
7.0	16 450	17 000	17 500	17 900	18 150	18 200	18 100	13 900				7.0
8.0	15 950	16 700	17 150	17 550	17 850	17 900	18 000	13 900	9 400			8.0
9.0	15 600	16 400	16 850	17 250	17 550	17 650	17 750	13 900	11 650	8 450		9.0
10.0	15 600	16 000	16 600	16 950	17 300	17 400	17 550	13 900	11 650	9 300	7 250	10.0
12.0	15 600	15 600	16 000	16 500	16 800	16 450	16 950	13 900	11 650	9 300	7 250	12.0
14.0		15 450	15 600	15 950	16 450	15 400	15 850	13 900	11 650	9 300	7 250	14.0
16.0		10 850	15 450	15 300	14 850	14 400	14 400	12 950	11 650	9 300	7 250	16.0
18.0			12 950	12 750	12 800	12 700	12 300	11 750	10 950	9 300	7 250	18.0
20.0				11 350	11 100	10 700	10 300	10 650	9 900	9 300	7 250	20.0
22.0				9 800	9 500	9 550	9 150	9 050	9 100	8 500	7 250	22.0
24.0					8 250	8 250	8 050	7 750	7 850	7 600	7 250	24.0
26.0					7 350	7 200	7 100	7 100	6 850	7 100	6 850	26.0
28.0					5 000	6 600	6 500	6 300	6 300	6 250	5 950	28.0
30.0						5 850	5 750	5 800	5 750	5 450	5 200	30.0
32.0							5 100	5 250	5 100	4 800	4 550	32.0
34.0							4 500	4 700	4 500	4 250	3 950	34.0
36.0								4 200	4 000	3 750	3 450	36.0
38.0								3 750	3 550	3 300	3 000	38.0
40.0									3 200	2 900	2 600	40.0
42.0									2 850	2 550	2 250	42.0
44.0										2 200	1 950	44.0
46.0										1 950	1 650	46.0
48.0											1 400	48.0

This information is not for crane operation. Operator must refer to the in- cab information for crane operation. Rated lifting capacities shown on fully extended outriggers do not exceed 85% of the tipping loads and on tires do not exceed 75% of the tipping loads.

7.2t Counterweight - Fully Extended Outriggers - 360° Rotation (All Capacities Are Listed In Pounds)									
50.2m Main Boom Length									
Radius (m)	10.7m Manual Offset Fly				17.7m Manual Offset Fly				Radius (m)
	0°	15°	30°	45°	0°	15°	30°	45°	
12.0	5 000								12.0
14.0	5 000								14.0
16.0	5 000	5 200			3 400				16.0
18.0	5 000	5 200			3 400				18.0
20.0	5 000	5 200	5 100		3 400	3 500			20.0
22.0	4 950	5 200	5 000	4 550	3 400	3 400			22.0
24.0	4 050	4 450	4 850	4 450	3 400	3 300	2 850		24.0
26.0	3 300	3 700	4 000	4 300	3 400	3 250	2 750		26.0
28.0	2 650	3 000	3 300	3 550	2 950	3 150	2 700	2 400	28.0
30.0	2 150	2 450	2 750	2 950	2 400	2 950	2 650	2 350	30.0
32.0	1 700	2 000	2 200	2 400	1 950	2 450	2 600	2 300	32.0
34.0	1 300	1 550	1 800	1 900	1 550	2 000	2 400	2 250	34.0
36.0	950	1 200	1 400	1 500	1 250	1 600	1 950	2 200	36.0
38.0	650	900	1 050	1 150	900	1 300	1 600	1 850	38.0
40.0		600	750	850	650	1 000	1 250	1 450	40.0
42.0				550		700	950	1 150	42.0
44.0							700	850	44.0
46.0								550	46.0

7.2t Counterweight - Fully Extended Outriggers - 360° Rotation (All Capacities Are Listed In Pounds)									
50.2m Main Boom Length									
Radius (m)	33.7m Manual Offset Fly				49.7m Manual Offset Fly				Radius (m)
	0°	15°	30°	45°	0°	15°	30°	45°	
16.0	2 400				1 800				16.0
18.0	2 400				1 800				18.0
20.0	2 400				1 800				20.0
22.0	2 400	2 400			1 800	1 900			22.0
24.0	2 400	2 300			1 800	1 900			24.0
26.0	2 400	2 250	2 000		1 800	1 800	1 650		26.0
28.0	2 400	2 150	1 900	1 750	1 800	1 750	1 600		28.0
30.0	2 400	2 100	1 850	1 700	1 800	1 650	1 550	1 450	30.0
32.0	2 000	2 000	1 800	1 650	1 800	1 600	1 450	1 400	32.0
34.0	1 600	1 950	1 750	1 600	1 600	1 550	1 400	1 350	34.0
36.0	1 250	1 650	1 700	1 550	1 250	1 500	1 350	1 300	36.0
38.0	950	1 300	1 650	1 550	950	1 350	1 300	1 250	38.0
40.0	650	1 000	1 300	1 500	650	1 000	1 250	1 200	40.0
42.0		750	1 000	1 200		750	1 050	1 150	42.0
44.0		500	750	900		500	750	950	44.0
46.0			500	650			500	700	46.0

This information is not for crane operation. Operator must refer to the in- cab information for crane operation. Rated lifting capacities shown on fully extended outriggers do not exceed 85% of the tipping loads and on tires do not exceed 75% of the tipping loads.

16.4t Counterweight - Fully Extended Outriggers - 360° Rotation (All Capacities Are Listed In Pounds)									
50.2m Main Boom Length									
Radius (m)	10.7m Manual Offset Fly				17.7m Manual Offset Fly				Radius (m)
	0°	15°	30°	45°	0°	15°	30°	45°	
12.0	5 000								12.0
14.0	5 000								14.0
16.0	5 000	5 200			3 400				16.0
18.0	5 000	5 200			3 400				18.0
20.0	5 000	5 200	5 100		3 400	3 500			20.0
22.0	5 000	5 200	5 000	4 550	3 400	3 400			22.0
24.0	5 000	5 200	4 900	4 450	3 400	3 300	2 850		24.0
26.0	4 950	5 200	4 850	4 350	3 400	3 250	2 750		26.0
28.0	4 900	5 200	4 750	4 250	3 400	3 150	2 700	2 400	28.0
30.0	4 250	4 550	4 600	4 200	3 400	3 050	2 650	2 350	30.0
32.0	3 650	3 950	4 150	4 150	3 400	3 000	2 600	2 300	32.0
34.0	3 150	3 400	3 600	3 750	3 400	2 900	2 500	2 250	34.0
36.0	2 700	2 900	3 100	3 250	2 950	2 800	2 450	2 250	36.0
38.0	2 300	2 500	2 650	2 800	2 550	2 750	2 400	2 200	38.0
40.0	1 950	2 150	2 300	2 350	2 200	2 500	2 350	2 200	40.0
42.0	1 650	1 800	1 950	2 000	1 900	2 150	2 350	2 150	42.0
44.0	1 350	1 500	1 600	1 650	1 600	1 850	2 100	2 150	44.0
46.0	1 100	1 250	1 350	1 350	1 350	1 600	1 800	1 900	46.0
48.0	850	1 000	1 050		1 100	1 300	1 500	1 600	48.0
50.0	650	750	800		900	1 100	1 250	1 300	50.0
52.0		500	550		650	850	1 000	1 050	52.0
54.0						650	800	800	54.0
56.0							550		56.0

16.4t Counterweight - Fully Extended Outriggers - 360° Rotation (All Capacities Are Listed In Pounds)									
50.2m Main Boom Length									
Radius (m)	33.7m Manual Offset Fly				49.7m Manual Offset Fly				Radius (m)
	0°	15°	30°	45°	0°	15°	30°	45°	
16.0	2 400				1 800				16.0
18.0	2 400				1 800				18.0
20.0	2 400				1 800				20.0
22.0	2 400	2 400			1 800	1 900			22.0
24.0	2 400	2 300			1 800	1 900			24.0
26.0	2 400	2 250	2 000		1 800	1 800	1 650		26.0
28.0	2 400	2 150	1 900	1 750	1 800	1 750	1 600		28.0
30.0	2 400	2 100	1 850	1 700	1 800	1 650	1 550	1 450	30.0
32.0	2 350	2 000	1 800	1 650	1 800	1 600	1 450	1 400	32.0
34.0	2 250	1 950	1 750	1 600	1 750	1 550	1 400	1 350	34.0
36.0	2 200	1 900	1 700	1 550	1 650	1 500	1 350	1 300	36.0
38.0	2 100	1 800	1 650	1 550	1 600	1 400	1 300	1 250	38.0
40.0	2 050	1 750	1 600	1 500	1 550	1 350	1 250	1 200	40.0
42.0	1 900	1 700	1 550	1 450	1 450	1 300	1 200	1 150	42.0
44.0	1 600	1 650	1 500	1 450	1 400	1 250	1 150	1 100	44.0
46.0	1 350	1 600	1 450	1 400	1 300	1 200	1 100	1 050	46.0
48.0	1 100	1 350	1 450	1 400	1 100	1 150	1 050	1 050	48.0
50.0	900	1 100	1 300	1 350	850	1 100	1 050	1 000	50.0
52.0	650	900	1 050	1 150	650	900	1 000	950	52.0
54.0		700	850	900		650	850	950	54.0
56.0			600	650			650	700	56.0
58.0								500	58.0

This information is not for crane operation. Operator must refer to the in- cab information for crane operation. Rated lifting capacities shown on fully extended outriggers do not exceed 85% of the tipping loads and on tires do not exceed 75% of the tipping loads.

**22.2t Counterweight - Fully Extended Outriggers - 360° Rotation**  
**(All Capacities Are Listed In Pounds)**

**50.2m Main Boom Length**

Radius (m)	10.7m Manual Offset Fly				17.7m Manual Offset Fly				Radius (m)
	0°	15°	30°	45°	0°	15°	30°	45°	
12.0	5 000								12.0
14.0	5 000								14.0
16.0	5 000	5 200			3 400				16.0
18.0	5 000	5 200			3 400				18.0
20.0	5 000	5 200	5 100		3 400	3 500			20.0
22.0	5 000	5 200	5 000	4 550	3 400	3 400			22.0
24.0	5 000	5 200	4 900	4 450	3 400	3 300	2 850		24.0
26.0	5 000	5 200	4 850	4 350	3 400	3 250	2 750		26.0
28.0	5 000	5 200	4 750	4 250	3 400	3 150	2 700	2 400	28.0
30.0	5 000	5 150	4 600	4 200	3 400	3 050	2 650	2 350	30.0
32.0	4 750	4 950	4 500	4 150	3 400	3 000	2 600	2 300	32.0
34.0	4 200	4 450	4 350	4 050	3 400	2 900	2 500	2 250	34.0
36.0	3 700	3 900	4 100	4 000	3 350	2 800	2 450	2 250	36.0
38.0	3 250	3 450	3 600	3 700	3 250	2 750	2 400	2 200	38.0
40.0	2 800	3 000	3 150	3 250	3 050	2 700	2 350	2 200	40.0
42.0	2 450	2 650	2 750	2 850	2 700	2 600	2 350	2 150	42.0
44.0	2 150	2 300	2 400	2 450	2 400	2 550	2 300	2 150	44.0
46.0	1 850	2 000	2 100	2 100	2 100	2 350	2 250	2 100	46.0
48.0	1 600	1 700	1 800		1 800	2 050	2 200	2 100	48.0
50.0	1 350	1 425	1 500		1 550	1 750	1 900	2 000	50.0
52.0	1 100	1 200	1 250		1 350	1 550	1 650	1 700	52.0
54.0	900	950	1 000		1 100	1 300	1 400	1 450	54.0
56.0	650	750			900	1 100	1 200		56.0
58.0					700	850	950		58.0
60.0					550	650	700		60.0

This information is not for crane operation. Operator must refer to the in- cab information for crane operation. Rated lifting capacities shown on fully extended outriggers do not exceed 85% of the tipping loads and on tires do not exceed 75% of the tipping loads.

**22.2t Counterweight - Fully Extended Outriggers - 360° Rotation**  
**(All Capacities Are Listed In Pounds)**

**50.2m Main Boom Length**

Radius (m)	33.7m Manual Offset Fly				49.7m Manual Offset Fly				Radius (m)
	0°	15°	30°	45°	0°	15°	30°	45°	
16.0	2 400				1 800				16.0
18.0	2 400				1 800				18.0
20.0	2 400				1 800				20.0
22.0	2 400	2 400			1 800	1 900			22.0
24.0	2 400	2 300			1 800	1 900			24.0
26.0	2 400	2 250	2 000		1 800	1 800	1 650		26.0
28.0	2 400	2 150	1 900	1 750	1 800	1 750	1 600		28.0
30.0	2 400	2 100	1 850	1 700	1 800	1 650	1 550	1 450	30.0
32.0	2 350	2 000	1 800	1 650	1 800	1 600	1 450	1 400	32.0
34.0	2 250	1 950	1 750	1 600	1 750	1 550	1 400	1 350	34.0
36.0	2 200	1 900	1 700	1 550	1 650	1 500	1 350	1 300	36.0
38.0	2 100	1 800	1 650	1 550	1 600	1 400	1 300	1 250	38.0
40.0	2 050	1 750	1 600	1 500	1 550	1 350	1 250	1 200	40.0
42.0	1 950	1 700	1 550	1 450	1 450	1 300	1 200	1 150	42.0
44.0	1 900	1 650	1 500	1 450	1 400	1 250	1 150	1 100	44.0
46.0	1 850	1 600	1 450	1 400	1 350	1 200	1 100	1 050	46.0
48.0	1 750	1 550	1 450	1 400	1 300	1 150	1 050	1 050	48.0
50.0	1 550	1 500	1 400	1 350	1 250	1 100	1 050	1 000	50.0
52.0	1 350	1 500	1 400	1 350	1 200	1 050	1 000	950	52.0
54.0	1 100	1 300	1 350	1 300	1 100	1 050	950	950	54.0
56.0	900	1 100	1 250	1 300	900	1 000	950	900	56.0
58.0	700	900	1 000	1 050	700	900	900	900	58.0
60.0	500	700	750		500	650	800	850	60.0
62.0		500	550			500	600	600	62.0

This information is not for crane operation. Operator must refer to the in- cab information for crane operation. Rated lifting capacities shown on fully extended outriggers do not exceed 85% of the tipping loads and on tires do not exceed 75% of the tipping loads.

**Link-Belt Cranes**      Lexington, Kentucky      [www.linkbelt.com](http://www.linkbelt.com)

©Link-Belt is a registered trademark. Copyright 2022. We are constantly improving our products and therefore reserve the right to change designs and specifications.