

Technical Data

Specifications & Capacities

ATC 3275

Telescopic Boom All Terrain Crane
275 US ton
250 metric ton

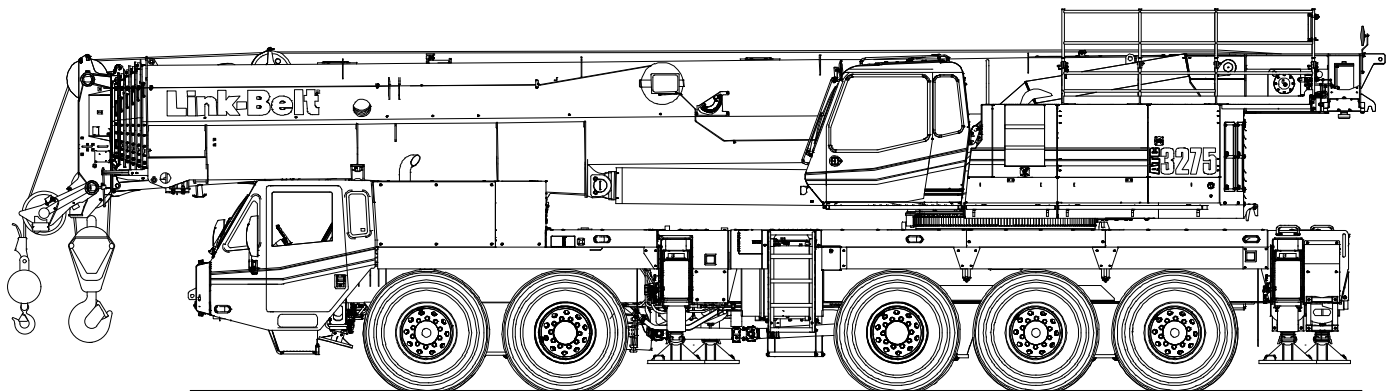

CAUTION: This material is supplied for reference use only. Operator must refer to in-cab Crane Rating Manual and Operator's Manual to determine allowable crane lifting capacities and assembly and operating procedures.

Table Of Contents

Boom, Attachments, and Upper Structure	1
Boom	1
Boom	1
Boom Wear Pads	1
Boom Head	1
Boom Elevation	1
Auxiliary Lifting Sheave – Optional	1
Heavy Duty Lifting Sheave Package – Optional	1
Hook Blocks and Balls – Optional	1
Fly – Optional	1
Fly Extensions – Optional	2
Upper Operator’s Cab and Controls	2
Swing	3
Central Lubrication System	3
Electrical	3
Hydraulic System	4
Pump Drive	4
Fuel Tank	4
Engine	4
Load Hoist System	5
Load Hoist Performance	5
2M Main (Front) and Optional Auxiliary (Rear) Winches	5
Counterweight	5
Carrier	7
General	7
Outriggers	7
Steering and Axles	7
Suspension	7
Ground Control Outrigger/Suspension Controls	7
Tires and Wheels	8
Brakes	8
Central Lubrication System	8
Electrical	8
Transmission	8
Fuel Tank	8
Engine	8
Hydraulic System	8
Pump Drive	8
Carrier Speeds and Gradeability	9
Lower Cab and Controls	10
Additional Equipment	11
Axle Loads – English	12
Axle Loads – Metric	13
Axle Loads with 2–Axle or 3–Axle Boom Dolly (3rd Axle Down) – English	14
Axle Loads with 2–Axle or 3–Axle Boom Dolly (3rd Axle Down) – Metric	15
General Dimensions	16

Boom Extend Modes	17
Working Range Diagram – Main Boom	18
Main Boom Lift Capacity Charts – Standard	19
0 lb Counterweight - Fully Extended Outriggers - 360° Rotation	19
36,000 lb Counterweight - Fully Extended Outriggers - 360° Rotation	20
Main Boom Lift Capacity Charts – Optional	21
80,000 lb Counterweight - Fully Extended Outriggers - 360° Rotation	21
102,000 lb Counterweight - Fully Extended Outriggers - 360° Rotation	22
156,500 lb Counterweight - Fully Extended Outriggers - 360° Rotation	23
Working Range Diagram – Main Boom + Fly	24
Manual & Hydraulic Offset Fly Attachment Lift Capacity Charts – Optional	25
36,000 lb Counterweight - Fully Extended Outriggers - 360° Rotation	25
Main Boom + 12 ft Offset Fly (Manual Offsets 2°, 15°, 30°, 45° & Hydraulic Offsets 2° - 45°)	25
36,000 lb Counterweight - Fully Extended Outriggers - 360° Rotation	26
Main Boom + 12 ft Offset Fly (Manual Offsets 2°, 15°, 30°, 45° & Hydraulic Offsets 2° - 45°)	26
156,500 lb Counterweight - Fully Extended Outriggers - 360° Rotation	27
Main Boom + 12 ft Offset Fly (Manual Offsets 2°, 15°, 30°, 45° & Hydraulic Offsets 2° - 45°)	27
156,500 lb Counterweight - Fully Extended Outriggers - 360° Rotation	28
Main Boom + 12 ft Offset Fly (Manual Offsets 2°, 15°, 30°, 45° & Hydraulic Offsets 2° - 45°)	28
Manual Offset Fly Attachment Lift Capacity Charts – Optional	29
36,000 lb Counterweight - Fully Extended Outriggers - 360° Rotation	29
223 ft Main Boom Length + 40 ft & 67 ft Manual Offset Fly (2°, 15°, 30°, 45° Offsets)	29
156,500 lb Counterweight - Fully Extended Outriggers - 360° Rotation	30
223 ft Main Boom Length + 40 ft & 67 ft Manual Offset Fly (2°, 15°, 30°, 45° Offsets)	30
223 ft Main Boom Length +92 ft & 117 ft Manual Offset Fly (2°, 15°, 30°, 45° Offsets)	31
Hydraulic Offset Fly Attachment Lift Capacity Charts – Optional	32
36,000 lb Counterweight - Fully Extended Outriggers - 360° Rotation	32
223 ft Main Boom Length + 40 ft & 67 ft Hydraulic Offset Fly (2°–45° Offsets)	32
156,500 lb Counterweight - Fully Extended Outriggers - 360° Rotation	33
223 ft Main Boom Length + 40 ft & 67 ft Hydraulic Offset Fly (2°–45° Offsets)	33
223 ft Main Boom Length +92 ft & 117 ft Hydraulic Offset Fly (2°–45° Offsets)	34
Metric Main Boom Lift Capacity Charts	35
0t Counterweight - Fully Extended Outriggers - 360° Rotation	35
16.3t Counterweight - Fully Extended Outriggers - 360° Rotation	36
Metric Main Boom Lift Capacity Charts – Optional	37
36.3t Counterweight - Fully Extended Outriggers - 360° Rotation	37
46.3t Counterweight - Fully Extended Outriggers - 360° Rotation	38
71.0t Counterweight - Fully Extended Outriggers - 360° Rotation	39
Metric Manual & Hydraulic Offset Fly Attachment Lift Capacity Charts – Optional	40
16.3t Counterweight - Fully Extended Outriggers - 360° Rotation	40
Main Boom + 3.7m Offset Fly (Manual Offsets 2°, 15°, 30°, 45° & Hydraulic Offsets 2° - 45°)	40
71.0t Counterweight - Fully Extended Outriggers - 360° Rotation	42
Main Boom + 3.7m Offset Fly (Manual Offsets 2°, 15°, 30°, 45° & Hydraulic Offsets 2° - 45°)	42

Metric Manual Offset Fly Attachment Lift Capacity Charts – Optional	44
16.3t Counterweight - Fully Extended Outriggers - 360° Rotation	44
68m Main Boom Length + 12.2m & 20.4m Manual Offset Fly ((2°, 15°, 30°, 45° Offsets)	44
71.0t Counterweight - Fully Extended Outriggers - 360° Rotation	45
68m Main Boom Length + 12.2m & 20.4m Manual Offset Fly ((2°, 15°, 30°, 45° Offsets)	45
68m Main Boom Length + 28m & 35.7m Manual Offset Fly ((2°, 15°, 30°, 45° Offsets)	46
Metric Hydraulic Offset Fly Attachment Lift Capacity Charts – Optional	47
16.3t Counterweight - Fully Extended Outriggers - 360° Rotation	47
68m Main Boom Length + 12.2m & 20.4m Hydraulic Offset Fly (2°–45° Offsets)	47
71.0t Counterweight - Fully Extended Outriggers - 360° Rotation	48
68m Main Boom Length + 12.2m & 20.4m Hydraulic Offset Fly (2°–45° Offsets)	48
68m Main Boom Length + 28m & 35.7m Hydraulic Offset Fly (2°–45° Offsets)	49

Boom, Attachments, and Upper Structure

■ Boom

Design — Seven section, formed construction of extra high tensile steel consisting of one base section and six telescoping sections. The two plate design of each section has multiple longitudinal bends for superior strength. Each telescoping section extends independently by means of one double – action, single stage hydraulic cylinder with integral holding valves.

Boom

- 43.7 – 223 ft (13.3 – 68m) seven section boom
- Integral boom dolly connection
- Boom removal quick disconnects
- Three pinned positions of 0%, 50%, and 100% on each boom section
- Mechanical boom angle indicator
- Wind speed indicator
- Eight boom extend modes (EM1 – EM8), controlled from the operator's cab, provide superior capacities by varying the extension of the telescoping sections:
 - EM1 extends to 223 ft (68m)
 - EM2 extends to 209.3 ft (63.8m)
 - EM3 extends to 177.5 ft (54.1m)
 - EM4 extends to 163.3 ft (49.8m)
 - EM5 extends to 133.4 ft (40.6m)
 - EM6 extends to 135.9 ft (41.4m)
 - EM7 extends to 105.4 ft (32.1m)
 - EM8 extends to 90.7 ft (27.6m)
- Maximum tip height for each extend mode is:
 - EM1 is 234.1 ft (71.3m)
 - EM2 is 220.5 ft (67.2m)
 - EM3 is 188.9 ft (57.6m)
 - EM4 is 174.8 ft (53.3m)
 - EM5 is 145.1 ft (44.2m)
 - EM6 is 147.6 ft (45.0m)
 - EM7 is 117.4 ft (35.8m)
 - EM8 is 102.8 ft (31.3m)

Boom Wear Pads

- Wear pads with Teflon inserts that self – lubricate the boom sections, inserts are universal for the boom.
- Bottom rear wear pads are universal for all boom sections.
- Top front wear pads are universal for all boom sections.
- Top rear wear pads are common for T3, T4, T5, and T6 boom sections
- Top rear wear pads are common for T1 and T2 boom sections

Boom Head

- Seven 16.53 in (41.99cm) root diameter nylon sheaves to handle up to 16 parts of line with auxiliary lifting sheave
- Easily removable wire rope guards
- Rope dead end lugs on either side of the boom head
- Boom head is designed for quick–reeve of the hook block

Boom Elevation

- One double acting hydraulic cylinder with integral holding valve
- Boom elevation: -1.5° to 83°

Auxiliary Lifting Sheave – Optional

- Single 16.53 in (41.99cm) root diameter nylon sheave
- Easily removable wire rope guards
- Does not affect erection of the fly or use of the main head sheaves
- Can be stored on right side of the boom without removal

Heavy Duty Lifting Sheave Package – Optional

- Six 16.53 in (41.99cm) root diameter nylon sheaves
- Easily removable wire rope guards
- Necessary to achieve greater than 16 parts of line

Hook Blocks and Balls – Optional

- 40 ton (36.3mt) 1 sheave quick–reeve hook block with safety latch
- 66 ton (60mt) 3 sheave quick–reeve hook block with safety latch
- 100 ton (91mt) 5 sheave quick–reeve hook block with safety latch
- 140 ton (127mt) 7 sheave quick–reeve hook block with safety latch
- 200 ton (181mt) 10 sheave quick–reeve hook block with safety latch
- 275 ton (250mt) base rating hook block – two 140 ton (127mt) 7 sheave quick–reeve hook blocks with safety latch and 275 ton (250mt) hook block equalizer
- 12 ton (10.9mt) swivel hook ball with safety latch

Fly – Optional

- 40 – 67 ft (12.19 – 20.42m) two piece bi-fold lattice fly, stowable, offsettable to 2° , 15° , 30° , and 45° . Maximum tip height is 301 ft (91.7m). Minimum of 36,000 lb (16 329kg) of counterweight required.
- 12-40-67 ft (3.65-12.19-20.42m) three piece bi-fold lattice fly, stowable, offsettable to 2° , 15° , 30° , and 45° . Maximum tip height is 301 ft (91.7m). Minimum of 36,000 lb (16 329kg) of counterweight required.
- 12-40-67 ft (3.65-12.19-20.42m) three piece bi-fold lattice fly, stowable hydraulically offsettable to 2° through 45° . Maximum tip height is 301 ft (91.7m). Minimum of 36,000 lb (16 329kg) of counterweight required.

Fly Extensions – Optional

- One 25 ft (7.62m) lattice extension, equipped with one 16.38 in (41.6cm) root diameter nylon deflector sheave to be mounted between the boom head and fly options. Maximum tip height of 325.3 ft (99.2m). Minimum of 58,000 lb (26 308kg) of counterweight required.
- Two 25 ft (7.62m) lattice extensions, equipped with one 16.38 in (41.6cm) root diameter nylon deflector sheave to be mounted between the boom head and fly options. Maximum tip height of 350 ft (106.7m). Minimum of 58,000 lb (26 308kg) of counterweight required.

■ Upper Operator's Cab and Controls

Environmental Cab – Fully enclosed, one person cab of galvanneal steel structure with acoustical insulation.

Equipped with:

- Tilting cab up to 20°
- Tinted and tempered glass windows
- Five way adjustable, cushioned seat with headrests, and seat belt
- Extra—large fixed front window with windshield wiper and washer
- Swing up roof window with windshield wiper
- Sliding left side door with large fixed window
- Sliding right side window for ventilation
- Engine dependent warm – water heater with air ducts for front windshield defroster and cab floor
- Defroster fan for the front window
- Bubble level
- Circulating fan
- Sun screen
- LED Dome light
- Cup holder
- Fire extinguisher
- Left side viewing mirror
- Two position travel swing lock
- AM/FM Radio

Air Conditioning – Integral with cab heating system utilizing the same ventilation outlets

Armrest Controls – Two dual axis electronic joystick controllers or optional single axis electronic controllers for:

- Swing
- Boom hoist
- Main front winch
- Auxiliary rear winch – optional
- Drum rotation indication
- Drum rotation indicator activation switch
- Winch high/low speed disable switch(es)
- Cab heater and A/C controls
- Throttle lock switch
- Throttle set/resume switch
- Cab tilt switch
- Counterweight handling switch
- Warning horn button
- Swing park brake
- Remote controlled boom flood light

Foot Controls

- Boom Telescope
- Swing brake
- Engine throttle

Right Front Console – Controls and indicators for:

- Warning horn button
- Function disable switch
- Cab floodlights switch
- Console dimmer switch
- 2–12 volt accessory outlets (Switched & Unswitched)
- Emergency engine shutdown
- Windshield wiper/washer switch
- Outrigger keypad
- Upper ignition switch
- Lower ignition switch
- DPF regeneration inhibit switch⁽¹⁾
- DPF regeneration initiate switch⁽¹⁾
- Single and dual boom floodlight switches
- Rotating beacon/strobe light switch – optional
- Hydraulic offset fly switch – optional

Camera Display – Located on dash console

- Displays right side of upper
- Displays main and auxiliary winches

Cab Instrumentation – Ergonomically positioned LCD display, CANBUS instrumentation for crane operation including:

- Tachometer
- Change Hydraulic filter indication
- Engine water temperature
- Fuel level
- Hydraulic oil temperature
- Stop engine
- Check engine
- Wait to start
- High exhaust temperature light⁽¹⁾
- Exhaust system cleaning light⁽¹⁾
- Exhaust system cleaning Disabled light⁽¹⁾
- Swing park brake light
- Fine metering function set & %
- Diesel exhaust fluid (DEF) Low Light⁽¹⁾
- Engine air filter high restriction Light
- Engine Running Hours
- Hydraulic Oil Life Indicator
- Engine Oil Life Indicator
- General Service Indicator
- Carrier engine indicator lights and gauges
- Engine oil pressure
- Battery voltage
- Engine hours
- Fuel rate (gal/hr)
- Engine load
- Third wrap indicator activation & setup
- Engine Diagnostics
- Electronic Control Diagnostics
- Outrigger level indicator
- Exhaust system cleaning inhibit switch⁽¹⁾
- Exhaust system cleaning initiate switch⁽¹⁾
- Service interval indicator
 - Hydraulic oil
 - Engine oil
 - Miscellaneous – user defined

⁽¹⁾ (Tier 4f/Stage IV engine only)

Diagnostic Center — Located on the left side of the front panel below the windshield

- Engine diagnostic
- RCL CANBUS diagnostic
- Boom CANBUS diagnostic
- Crane Controller USB diagnostic
- RCL controller USB diagnostic
- Manual boom control connection
- Manual crane control connection

Link-Belt Pulse — The Link-Belt in-house designed, total crane operating system that utilizes the display as a readout and operator interface for the following systems:

- **Rated capacity limiter** — LCD graphic audio — visual warning system integrated into the dash with anti — two block and function limiter. Operating data includes:
 - Crane configuration
 - Boom length
 - Boom head height
 - Allowed load and % of allowed load
 - RCL light bar
 - Boom angle
 - Radius of load
 - Actual load
 - Wind speed
 - Highlighted unit of measurement on working screen
 - Active pin/latch status
 - Telescope operation displayed in real time
 - Counterweight installation/removal
 - Third wrap indicator
 - Diagnostics
 - Outrigger position sensing
 - Drum rotation direction indicator
 - Operator settable alarms (include):
 - Maximum and minimum boom angles
 - Maximum tip height
 - Maximum boom length
 - Swing left/right positions
 - Operator defined area (imaginary plane)
- **Telematics** — Cellular—based data logging and monitoring system that provides:
 - Location and operational settings
 - Routine maintenance
 - Crane and engine monitoring
 - Diagnostic and fault codes
- **Extend control module (ECM)**
 - Controls the extend modes
 - Diagnostics
- **Electronic controllers**
 - Controls all load lifting functions
 - Diagnostics
- **Fine metering**
 - Controls the reaction speeds of the main and auxiliary winches, boom hoist, and swing functions
 - Diagnostics

Integrated Third Wrap Indicator — Optional — Link-Belt Pulse color display visually and audibly warns the operator when the wire rope is on the first/bottom layer and when the wire rope is down to the last three wraps.

Integrated Third Wrap Function Kickout — Optional — Link—Belt Pulse color display visually and audibly warns the operator when the wire rope is on the first/bottom layer and provides a function kickout when the wire rope is down to the last three wraps.

Internal RCL Light Bar — Visually informs the operator when crane is approaching maximum load capacity with a series of green, yellow, and red lights.

External RCL Light Bar — Optional — Visually informs the ground crew when crane is approaching maximum load capacity with a series of green, yellow, and red lights.

■ Swing

Motor/Planetary — Two bi-directional hydraulic swing motors mounted to planetary reduction units for 360° continuous smooth swing at 1.5 rpm.

Swing Park Brake — 360°, electric over hydraulic, (spring applied/hydraulic released) multi—disc brake mounted between the speed reducer and the motor. Operated by a switch in the operator's cab.

Swing Brake — 360°, foot operated, hydraulic applied disc brake mounted to the reduction unit.

Swing Lock — Two — position swing lock (boom over the front or rear) operated from the operator's cab.

360° Positive Swing Lock — Optional — Meets New York City requirement.

■ Central Lubrication System

Automated lubrication unit that injects grease into the turntable bearing, boom hoist cylinder pins, boom foot pins, house lock (2—position), and cab tilt cylinder. Activated by a timer on the ignition switch.

■ Electrical

Two batteries provide 12 — volt operation and starting. CANBUS wiring and components.

Swing Alarm — Audio/Visual warning device signals when the upper is swinging.

Lights

- Two LED working lights on the front of the cab
- Work Lighting Package
 - Includes six (6) LED lights
 - Working light on top of the cab
 - Right side of superstructure facing forward
 - Left & right upper work platforms
 - Left & right sides of superstructure facing down
- One amber strobe beacon on top of the cab — optional
- Boom floodlight
- Boom floodlight — Dual
- Boom floodlight — High intensity remote controlled

Power Panel — Sealed power panel containing:

- Battery disconnects
- Hour meter
- Fuses, circuit breakers, relays, diodes, resistors
- Control modules

Hydraulic System

Main Pumps

- Two piston pumps for boom hoist and telescope
- Two piston pumps for main and auxiliary winches
- One piston pump for swing
- One piston pump for counterweight removal and hydraulic fly option
- One gear pump for engine fan
- One gear pump for upper oil cooler fan
- The upper engine powers the pumps. Combined pump capacity of 218 gpm (825.2Lpm).

Hydraulic Reservoir – 168 gal (635.9L) capacity equipped with sight level gauge. Diffusers built in for deaeration, and magnetic drain plug.

Filtration

- One, 7 – micron filter inside hydraulic reservoir, accessible for easy replacement
- One, 7 – micron charge filter next to the reservoir with an in – cab indicator light
- One suction strainer inside the hydraulic reservoir

“Fine inching” Mode – Special fine metering settings, selectable from the LCD, allows very slow movements to the main and auxiliary winches, boom hoist, and swing for precision work.

Counterbalance Valves – Boom extend cylinder and boom hoist cylinder are equipped with counterbalance valves to provide load lowering and prevents accidental load drop when hydraulic power is suddenly reduced.

Hydraulic Oil Cooler – Mounted on right side above telescoping valve. Removes heat from the hydraulic oil.

Boom Hoist Float Valves – For transporting the boom over the rear of the crane with a boom dolly. Allows hydraulic oil within the boom hoist cylinder to flow between piston side and case side.

Swing Brake Release Valve – For transporting the boom over the rear of the crane with a boom dolly. Holds the 360° swing park brake in the released position allowing free rotation of the upper structure.

Pump Drive

All pumps are mechanically driven by the diesel engine.

Fuel Tank

One 58 gal (219.5L) capacity aluminum diesel tank.

One 5 gal (18.9L) capacity diesel exhaust fluid (DEF) plastic tank.

Engine

Specification	Cummins QSB–6.7	
	Tier 4f/Stage IV ⁽¹⁾	Tier 3/Stage IIIA ⁽²⁾
Emissions Compliance Level	Tier 4f/Stage IV ⁽¹⁾	Tier 3/Stage IIIA ⁽²⁾
Maximum allowable sulfur content of fuel (PPM):	15	5,000
Numbers of cylinders	6	6
Cycle	4	4
Bore and Stroke: inch (mm)	4.21 x 4.88 (106.9 x 124)	4.21 x 4.88 (106.9 x 124)
Piston Displacement: in ³ (cm ³)	408 (6 702)	408 (6 702)
Max. Brake Horsepower: hp (kW)	215 (160) @ 1,800 rpm	205 (152) @ 1,800 rpm
Peak Torque: ft lb (Nm)	700 (949) @ 1,500 rpm	685 (928) @ 1,500 rpm
Alternator: volts – amps	12 – 160	12 – 160
Crankcase Capacity: qt (L)	19 (18)	19 (18)
<ul style="list-style-type: none"> • Water/fuel separator w/ heater and water in fuel (WIF) sensor • 120–volt block heater – Tier 4f/Stage IV • 220–volt block heater – Tier 3 / Stage IIIA • Grid heater – 200 amp • Mechanically driven, variable speed, engine controlled, viscous fan clutch • ⁽¹⁾ Can only be sold and/or operated where Tier 4f/Stage IV off–highway emission standards are accepted. • ⁽²⁾ Can only be sold and/or operated where Tier 3/Stage IIIA off–highway emission standards are accepted. 		

■ Load Hoist System

Load Hoist Performance

Main (Front) and Auxiliary (Rear) Winches – 7/8 in Rope										
Layer	Maximum Line Pull		Normal Line Speed		High Line Speed		Layer		Total	
	lb	kN	ft/min	m/min	ft/min	m/min	ft	m	ft	m
1	25,955	115.5	131	39.9	262	79.9	125	38.1	125	38.1
2	23,418	104.2	145	44.2	291	88.7	138	42.0	263	80.1
3	21,332	94.9	160	48.8	319	97.2	152	46.3	414	126.1
4	19,588	87.1	174	53.0	348	106.0	165	50.3	579	176.5
5	18,108	80.5	188	57.3	376	114.6	179	54.6	758	231.0
6	16,835	74.9	202	61.5	405	123.4	192	58.5	950	289.5

Wire Rope Application	Diameter in	Type	Maximum Permissible Load	
			lb	kN
Main	Standard	7/8	37x7 non-rotating – right lang lay (Type KC)	
	Optional	7/8	34x7 rotation resistant – right regular lay (Type ZB)	
	Optional	7/8	34x7 rotation resistant – right regular lay (Type YB)	
Auxiliary	Standard	7/8	37x7 non-rotating – right lang lay (Type KC)	
	Optional	7/8	34x7 rotation resistant – right regular lay (Type ZB)	
	Optional	7/8	34x7 rotation resistant – right regular lay (Type YB)	

2M Main (Front) and Optional Auxiliary (Rear) Winches

- Axial piston, full and half displacement (2-speed) motors driven through planetary reduction unit for positive control under all load conditions
- Grooved lagging
- Power up/down mode of operation
- Hoist drum cable followers – optional
- Drum rotation indicators
- Drum diameter: 15 in (38.1cm)
- Rope diameter: 22mm (0.875 in)
- Rope length:
 - Main (Front) 950 ft (289.5m)
 - Auxiliary (Rear) 725 ft (221m) or 950 ft (289.5m)
- Maximum rope storage: 951 ft (289.9m)
- Terminator style socket and wedge

■ Counterweight

Standard – Total of 36,000 lbs (16.3t) of total counterweight consisting of two hydraulically removable counterweights. Assembled and disassembled by hydraulic cylinders controlled from the operator's cab with capacities for:

- 0 lb (0t) counterweight
- 14,000 lb (6.4t) counterweight
- 36,000 lb (16.3t) counterweight

Optional – 44,000 lb (20.0t) in addition to standard counterweight for a total of 80,000 lb (36.3t) counterweight for additional capacities for:

- 58,000 lb (26.3t) counterweight
- 80,000 lb (36.3t) counterweight

Optional – 79,500 lb (36.1t) in addition to standard counterweight for a total of 115,500 lbs (52.4t) counterweight for additional capacities for:

- 58,000 lb (26.3t) counterweight
- 80,000 lb (36.3t) counterweight
- 102,000 lb (46.3t) counterweight
- 115,500 lbs (52.4t) counterweight

Optional – 120,500 lb (54.7t) in addition to standard counterweight for a total of 156,500 lbs (71.t) counterweight for additional capacities for:

- 58,000 lb (26.3t) counterweight
- 80,000 lb (36.3t) counterweight
- 102,000 lb (46.3t) counterweight
- 115,500 lb (52.4t) counterweight
- 156,500 lb (71.0t) counterweight*

Low speed jobsite travel is offered for all counterweight configurations and a boom dolly or boom trailer may be required for on-highway travel.

*Overall width of the crane increases to 15 ft 2 in (4.6m).

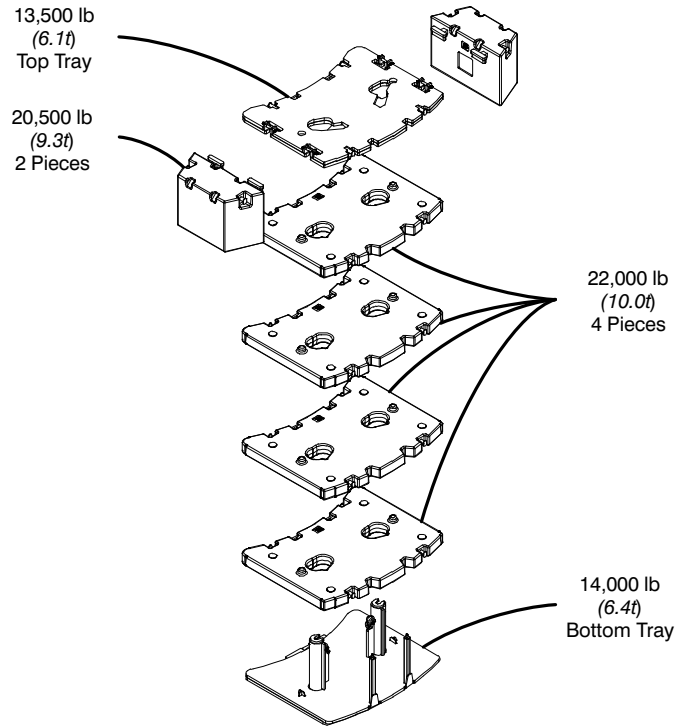

Counterweight Packages		36,000 lb (16.3t) – Standard						
		80,000 lb (36.3t) – Optional						
		115,500 lb (52.4t) – Optional						
		156,500 lb (71.0t) – Optional						
Counterweight Modules		14,000 lb (6.4t) Bottom Tray	22,000 lb (10t) piece	22,000 lb (10t) piece	22,000 lb (10t) piece	(22,000 lb (10t) Piece	13,500 lb (6.1t) Top Tray	20,500lb (9.3t) 2–Piece
Counterweight Usage Configurations	0 lb (0t)							
	14,000 lb (6.4t)	X						
	36,000 lb (16.3t)	X	X					
	58,000 lb (26.3t)	X	X	X				
	80,000 lb (36.3t)	X	X	X	X			
	102,000 lb (46.3t)	X	X	X	X	X		
	115,500 lb (52.4t)	X	X	X	X	X	X	
	156,500 lb (71.0t)	X	X	X	X	X	X	X

Carrier

General

- 9 ft 10 in (3.0m) wide
- 28 ft 9 in (8.76m) wheel base (centerline of first axle to centerline of fifth axle)
- **Frame** — Box — type, torsion resistant, welded construction made of high tensile steel. Equipped with front and rear tie — down lugs and access ladders.

Outriggers

Boxes — Two double box, front and rear welded to the carrier frame

Beams and Jacks — Four dual stage beams with Confined Area Lifting Capacities (CALC) provide selectable outrigger extensions of full, intermediate, and retracted positions. Jacks with integral check valves, hydraulically controlled from the operator's cab and on both sides of the carrier. A fifth front bumper outrigger, 16 in (40.64cm) with integral check valves hydraulically controlled from the operator's cab, both sides of carrier, and at the front bumper of carrier.

Pontoons

- **Main** — Four stow'n go, 22.25" (56.52cm) square steel pontoons with a contact area of 385 in² (2 483.8cm²) can be stored for road travel under the outrigger boxes
- **Front Bumper** — One, lightweight, self-storing, 16" (40.6cm) diameter steel pontoon with a contact area of 201 in² (1 296cm²)

Outrigger Work Station Floodlights — LED Flood lights are mounted at each outrigger beam and 5th outrigger.

Jack Reaction

- **Main** — 203,000 lb (903.0kN) force and 527 psi (3 633.5kPa) ground bearing pressure. Consult factory for base rating ground bearing pressure information.
- **Front Bumper** — 76,000 lb (338.1kN) force and 378 psi (2 606kPa) ground bearing pressure

Steering and Axles

- Sheppard full integral master gear/slave gear steering system provides hydraulic assisted steering with mechanical link between steering wheel and wheels

On Highway (Primary) Steering Mode — Axles 3, 4, and 5 will automatically steer in combination with axles 1 and 2 based on travel speed:

On-Highway (Primary)			
Speed	Less than 18.6 mph (30km/h)	18.6-31 mph (30-50km/h)	Greater than 31 mph (50km/h)
Axle 1	Steered	Steered	Steered
Axle 2	Steered	Steered	Steered
Axle 3	Steered	Locked	Locked
Axle 4	Steered	Locked	Locked
Axle 5	Steered	Steered	Locked

Off Road (Auxiliary) Steering Modes — Four independent modes consisting of:

- **All Wheel:** Axles 1, 2, 3, 4, and 5
- **Diagonal (Crab):** Axles 1, 2, 3, 4, and 5
- **Independent Rear:** Axles 3, 4, and 5
- **Drive Away From Walls:** Temporary crab

The front, all wheel, and diagonal (crab) steering modes are controlled from the steering wheel and are selected by controls in the driver's cab. Switches in the driver's cab control the rear steering mode through the steering module display.

- **Emergency Steering** — A pump is flange-mounted to the transmission and provides hydraulic pressure to the steering circuit as long as the crane is in motion
- **Drive** — 10 x 6 for on/off—highway travel
- **Axle 1** — Steered, driven
- **Axle 2** — Steered
- **Axle 3** — Steered
- **Axle 4** — Steered, driven
- **Axle 5** — Steered, driven
- **Inter-Axle Differential Lock** — Traction aiding device that locks axles 1, 4, and 5. Operated by a switch in the carrier cab.
- **Transverse (Cross-Axle) Differential Locks** — Traction aiding device that locks differentials within axles 1, 4, and 5. Operated by a momentary switch in the carrier cab.

Suspension

Hydro — pneumatic, lockable with level adjustment and automatic ride height leveling. All axles have longitudinal and transverse trailing arms with leveling adjustment and lockable cylinders. The carrier can be raised and lowered by controls in the carrier cab that adjust the suspension cylinders.

- Cylinder stroke: -4.5 in (-11.43cm)/+3.5 in (8.89cm) at ride height

Ground Control Outrigger/Suspension Controls

Environmentally sealed and ergonomically positioned, control stations located on both sides of the carrier with controls for crane operations including:

- Start and stop carrier engine
- Throttle carrier engine up and down
- Raise suspension on outriggers
- Outrigger operation including:
 - Extends and retracts two beams together
 - Extends and retracts all main jacks together
 - Extend and retract fifth (bumper) outrigger
 - Automatic leveling on outriggers
- Outrigger lighting
- Bubble level

■ Tires and Wheels

Standard – Ten (single) 525/80R25 tires on aluminum disc wheels

Optional – Ten (single) 445/95R25 tires on aluminum disc wheels

- Tire inflation kit – optional
- Spare tires and wheels – optional

■ Brakes

Service – Air anti-lock (ABS) braking system. Disc brakes on all wheel ends. Dual circuit compressed air system with air dryer.

Parking/Emergency – Spring loaded type, acting on 3rd, 4th, and 5th axles automatically apply when air pressure drops below 40 psi (275kPa) in both circuits.

Intarder – Hydrodynamic driveline brake that is integral to the transmission. Activated by a switch in the carrier cab and controlled by a lever on the steering column.

Traction Control – ABS activated traction control to limit wheel slip of axles 2, 4, and 5.

■ Central Lubrication System

Automated lubrication unit that injects grease into the steering gear arms, steering knuckles, axle king pins, and suspension cylinders. Activated by a timer on the ignition switch.

■ Electrical

Battery – Three batteries provide 12 volt starting and operation, easily accessible battery disconnects, and battery jumping posts

Lights

- Front lighting includes two main daytime running/headlights, two high beam lights, two LED parking/directional indicators, and three LED cab marker lights
- Side lighting includes four parking/directional indicators per side
- LED Rear lighting includes two parking/directional indicators, two parking/brake lights, two reverse lights, three marker lights, and a license plate light
- Other equipment includes hazard/warning system, cab LED light, instrument panel light, signal horn, two outrigger LED lights on each side, and 5th outrigger light
- One amber strobe beacon behind the cab

■ Transmission

Main Transmission – Automated – ZF AS-Tronic (no clutch pedal) manual transmission with 12 forward gears and 2 reverse gears.

Auxiliary Transmission – Air actuated manual transmission with high/low range

■ Fuel Tank

- One 95 gal (359.6L) capacity aluminum fuel tank
- One 10 gal (37.8L) capacity diesel exhaust fluid (DEF) plastic tank

■ Engine

Specification	Cummins ISX 15	Cummins QSX15
Emission compliance level:	EPA 2017 ⁽¹⁾	Tier 3/Stage IIIA ⁽²⁾
Maximum allowable sulfur content of fuel (PPM):	15	5,000
Numbers of cylinders	6	6
Cycle	4	4
Bore and Stroke: inch (mm)	5.39 x 6.65 (136.9x169)	5.39 x 6.65 (136.9x169)
Piston Displacement: in ³ (cm ³)	912 (14 945)	912 (14 945)
Max. Brake Horsepower: hp (kW)	550 (410) @ 2,000 rpm 564 (421) @ 1,700 rpm	555 (413) @ 1,800 rpm 520 (387) @ 2,100 rpm
Peak Torque: ft lb (Nm)	1,850 (2 508) @ 1,200 rpm	1,744 (2 364) @ 1,400 rpm
Alternator: volts – amps	12 – 160	12 – 160
Crankcase Capacity: qt (L)	48 (45.4)	48 (45.4)

- Cruise control
- Cummins ISX Three stage engine compression brake
- Thermostatically controlled, hydraulically driven radiator fan
- 120 volt engine block heater – ISX
- Ether injection system – optional on ISX
- Grid heater starting aid standard on QSX
- 220 volt engine block heater – QSX
- Cummins QSX Two stage compression brake

- (1) Can only be sold and/or operated where EPA 2017 on-highway emission standards are accepted.
- (2) Can only be sold and/or operated where Tier 3/Stage IIIA off-highway emission standards are accepted.

■ Hydraulic System

All functions are hydraulically powered allowing positive, precise control with independent or simultaneous operation of all functions.

Main Pumps

- Two section fixed displacement gear pump for 1st and 2nd axle steering circuits, suspension, outriggers, and 3rd and 4th axle steering circuits
- One fixed displacement gear pump for 5th axle steering circuit
- One fixed displacement piston pump for cooling fan circuit
- Combined pump capacity of 66 gpm (249.8Lpm)

Hydraulic Reservoir – 57 gal (215.7L) capacity equipped with sight level gauge. Diffusers built in for deaeration.

Filtration – Two 10 micron, full flow return line filters. All oil is filtered prior to return to reservoir. Accessible for easy filter replacement.

■ Pump Drive

- Engine fan, outriggers, steering, and suspension pumps mounted to the back of engine
- Rear steering pump mounted to back of air compressor
- Ground driven pump mounted to back of transmission

Carrier Speeds and Gradeability

ZF AS–Tronic Transmission		Speed				Gradeability (@ peak torque Except Creep @ Idle)	
Gear	Ratio	High Range (0.804)		Low Range (1.781)		% Grade	
		mph	km/h	mph	km/h	Min.	Max.
12th	0.78	62.00	99.78	26.33	42.37	1.51	5.20
11th	1.00	45.50	73.23	20.54	33.06	2.46	6.95
10th	1.27	35.83	57.66	16.17	26.02	3.51	9.06
9th	1.62	28.09	45.21	12.68	20.41	4.81	11.78
8th	2.10	21.67	34.87	9.78	15.74	6.54	15.49
7th	2.69	16.91	27.21	7.64	12.30	8.63	20.04
6th	3.56	12.78	20.57	5.77	9.29	11.68	26.75
5th	4.57	9.96	16.03	4.49	7.23	15.20	34.52
4th	5.78	7.87	12.67	3.55	5.71	19.42	43.84
3rd	7.41	6.14	9.88	2.77	4.46	25.09	56.38
2nd	9.59	4.74	7.63	2.14	3.44	27.01	60.61
1st	12.29	3.70	5.95	1.67	2.69	26.87	60.29
Reverse (1)	11.38	4.00	6.44	1.80	6.13	26.90	60.36
Reverse (2)	8.88	5.12	8.24	2.31	7.85	27.03	60.66
1st @ 700 rpm	12.29	1.30	2.09	0.58	0.93		
Reverse (1) @ 700 rpm	11.38	1.40	2.25	0.63	1.01		
Reverse (2) @ 700 rpm	8.88	1.79	2.88	0.81	1.30		

Based on a gross vehicle weight of 136,000 lb (61 688.5kg) using 525/80R25 tires

■ Lower Cab and Controls

Environmental Cab – Fully enclosed, one person cab of composite structure with acoustical insulation. Equipped with:

- Tinted and tempered glass windows
- Roll down left side window for ventilation
- Intermittent windshield wiper and washer
- Six way adjustable and air suspended driver's seat with seat belt
- Two heated and electrically adjustable side view mirrors
- Engine dependent warm–water heater with air ducts for windshield defroster and cab floor
- Adjustable sun visor
- LED dome light
- Fire extinguisher

Air Conditioning – Integral with cab heating system utilizing the same ventilation outlets

Overhead Console – Located above the sun visor

- Document storage unit
- AM/FM Radio
- Strobe beacon switch

Camera Display – Located on dash console:

- Displays right side of machine
- Displays rear view

Power Panel – Sealed power panel behind carrier cab containing:

- Main circuit breakers & relays
- Rear steer modules
- ABS modules
- 12/24 volt convertor

Cab Instrumentation – Ergonomically positioned instrumentation for driving including:

- Speedometer with odometer, hour meter, trip meter, and clock
- Tachometer
- Front and rear system air pressure with warning indicator
- Diesel exhaust fluid (DEF) level with warning indicator⁽¹⁾

Dash Mounted Controls For:

- Carrier lights
- Console dimmer switch
- Remote mirror control switches
- Mirror heating switch
- Cab heater/air conditioning switch
- Fresh/Recirculation air switch
- Park brake air valve
- Trailer brake air valve
- Carrier engine ignition switch

Dash Mounted Indicators For:

- Turn signal indication
- High beam headlights

Right Side Diagonal LCD Display – Ergonomically positioned on the right of driver's dash panel, digital instrumentation and indicators for crane operations including:

Gauges

- Engine water temperature
- Engine oil pressure
- Fuel level
- Voltmeter

Indicator Lights

- Regeneration inhibit⁽¹⁾
- Check engine
- Stop engine
- Exhaust regeneration⁽¹⁾
- High exhaust temperature⁽¹⁾
- Wait to start
- Malfunction indicator lamp⁽¹⁾
- Engine air filter high restriction light
- Cruise
- Park brake
- ABS
- Trailer ABS
- Steer computer
- Steer pump
- Steer hydraulic oil level
- Transaxle (cross–axle) differential lock
- Inter–axle differential lock
- Transfer case
- Travel mode
- Ride height
- Diesel Exhaust Fluid (DEF) level⁽¹⁾
- Seat belt
- Traction control

Diagnostic Screens

- Engine
- After treatment
- Suspension/Outriggers
- Intarder

Right Side Console – Controls and indicators for:

- Transmission gear shifting
- Transmission digital readout
- Cruise controls
- Engine compression brake controls
- Steering electronic control panel
- Console dimmer switch
- Auxiliary transmission range selector switch
- Intarder on/off switch
- Diesel particulate filter switch⁽¹⁾
- Regeneration inhibit switch⁽¹⁾
- Fan override switch
- ABS Traction control switch
- Transaxle (cross–axle) differential lock switch with indicator light
- Inter–axle differential lock switch with indicator light
- Travel mode switch
- Front axles (axles 1 & 2) suspension height switch
- Rear axles (axles 3–5) suspension height switch
- Ride height switch
- 2/12 volt accessory outlet (switched & unswitched)

Steering Column Controls For:

- Turn signal switch
- High beam switch
- Steering wheel adjustments
- Warning horn
- Hazard light switch
- Intarder brake control lever
- Intermittent windshield wiper and washer

Foot Controls For:

- Carrier service brakes
- Engine throttle

⁽¹⁾ (EPA 2017 engine only)

Fuse & Diagnostic Center – Located inside cab behind seat contains:

- Fuses, Relays
- Control Modules
- Diagnostic ports
 - Suspension diagnostic
 - Engine diagnostic
 - ABS Diagnostic
 - Cab display diagnostic
 - Intruder Diagnostic
 - Transmission Diagnostic
 - Steering Diagnostic

■ Additional Equipment

Standard:

- Aluminum full deck fenders with mud flaps
- One right side aluminum storage box with ladder
- Air hose connection ports
- Clearance flags
- Front and rear anchor shackles
- Pneumatic and electrical quick disconnect connections mounted to the rear for trailer or boom dolly brakes and lights

Optional:

- Rear mounted pintle hook
- Boom removal kit

Axle Loads – English

Base crane with full tanks of fuel and no counterweight	Gross Vehicle Weight (1)	Axle 1	Axle 2	Axle 3	Axle 4	Axle 5
	lb	lb	lb	lb	lb	lb
	134,077	27,175	26,724	26,331	27,015	26,831
Driver in carrier cab	250	177	177	-34	-34	-34
Remove pontoons	-431	-15	-15	-134	-134	-134
Ether injector	5	4	4	-1	-1	-1
Rear pintle hook	44	-13	-13	23	23	23
16.00R25 (445/95R25) tires (instead of standard)	-1,008	-202	-202	-202	-202	-202
Carrier cab strobe light	5	4	4	-1	-1	-1
Hoist drum follower - main	96	-25	-25	49	49	49
Auxiliary winch with 725 ft (221m) of 7/8" (22mm) wire rope	3,205	-988	-988	1,727	1,727	1,727
Remove auxiliary winch with 725 ft (221m) of 7/8" (22mm) wire rope	-2,923	925	925	-1,591	-1,591	-1,591
Hoist drum follower - auxiliary	96	-36	-36	56	56	56
Remove 950 ft (289.5m) of wire rope from front (main) winch	-1,454	334	334	-707	-707	-707
Remove 725 ft (221mm) of wire rope from rear (auxiliary) winch	-1,109	303	303	-572	-572	-572
Substitute 725 ft (221mm) of rope with 950 ft (289.5m) of rope - rear (auxiliary)	344	-94	-94	177	177	177
Substitute 950 ft (289.5m) of rope with 725 ft (221m) of rope - front (main)	-344	79	79	-167	-167	-167
360° mechanical swing lock	151	-52	-52	85	85	85
Boom launching option	77	-10	-10	32	32	32
Floodlight to the front of the boom base section	7	5	5	-1	-1	-1
Fly mounting brackets to boom base section for fly options	309	145	145	6	6	6
12 ft (3.65m) manual and hydraulically offsettable, lattice fly - stowed	2,340	1,755	1,755	-390	-390	-390
12-40 ft (3.65-12.2m) manual and hydraulically offsettable, two-piece (bi-fold) lattice fly - stowed	3,879	2,177	2,177	-158	-158	-158
12-40-67 ft (3.65-12.2-20.4m) manual and hydraulically offsettable, three-piece (bi-fold) lattice fly - stowed	5,062	2,425	2,425	71	71	71
Additional components for hydraulically offsettable fly	422	211	211	0	0	0
Auxiliary lifting sheave	112	102	102	-31	-31	-31
40 ton (36.3mt) 1 sheave hook block at front bumper	1,450	1,138	1,138	-275	-275	-275
66 ton (60mt) 3 sheave hook block at front bumper	1,900	1,491	1,491	-360	-360	-360
100 ton (91mt) 5 sheave hook block at front bumper	2,250	1,765	1,765	-427	-427	-427
140 ton (127mt) 7 sheave hook block at front bumper	2,850	2,236	2,236	-541	-541	-541
200 ton (181mt) 10 sheave hook block at front bumper	3,200	2,511	2,511	-607	-607	-607
12 ton (10.9mt) hookball at front bumper	722	566	566	-137	-137	-137

(1) Adjust gross vehicle weight and axle loading according to component weight. All weights are $\pm 3\%$.

Tire	Maximum Axle Load @ 50 mph Average Speed
20.5R25 (525/80R25) on aluminum disc wheels	28,004 lb
16.00R25 (445/95R25) on aluminum disc wheels	29,224 lb

Axle Loads – Metric

Base crane with full tanks of fuel and no counterweight	Gross Vehicle Weight ⁽¹⁾	Axle 1	Axle 2	Axle 3	Axle 4	Axle 5
	kg	kg	kg	kg	kg	kg
	60 816	12 327	12 122	11 944	12 254	12 170
Driver in carrier cab	113	80	80	-16	-16	-16
Remove pontoons	-195	-7	-7	-61	-61	-61
Ether injector	2	2	2	0	0	0
Rear pintle hook	20	-6	-6	11	11	11
16.00R25 (445/95R25) tires (instead of standard)	-457	-91	-91	-91	-91	-91
Carrier cab strobe light	2	2	2	0	0	0
Hoist drum follower - main	44	-11	-11	22	22	22
Auxiliary winch with 725 ft (221m) of 7/8" (22mm) wire rope	1 454	-448	-448	783	783	783
Remove auxiliary winch with 725 ft (221m) of 7/8" (22mm) wire rope	-1 326	419	419	-722	-722	-722
Hoist drum follower - auxiliary	44	-16	-16	25	25	25
Remove 950 ft (289.5m) of wire rope from front (main) winch	-659	151	151	-321	-321	-321
Remove 725 ft (221m) of wire rope from rear (auxiliary) winch	-503	137	137	-259	-259	-259
Substitute 725 ft (221m) of rope with 950 ft (289.5m) of rope - rear (auxiliary)	156	-43	-43	80	80	80
Substitute 950 ft (289.5m) of rope with 725 ft (221m) of rope - front (main)	-156	36	36	-76	-76	-76
360° mechanical swing lock	69	-23	-23	39	39	39
Boom launching option	35	-5	-5	15	15	15
Floodlight to the front of the boom base section	3	2	2	-1	-1	-1
Fly mounting brackets to boom base section for fly options	140	66	66	3	3	3
12 ft (3.65m) manual and hydraulically offsettable, lattice fly - stowed	1 061	796	796	-177	-177	-177
12-40 ft (3.65-12.2m) manual and hydraulically offsettable, two-piece (bi-fold) lattice fly - stowed	1 759	987	987	-72	-72	-72
12-40-67 ft (3.65-12.2-20.4m) manual and hydraulically offsettable, three-piece (bi-fold) lattice fly - stowed	2 296	1 100	1 100	32	32	32
Additional components for hydraulically offsettable fly	192	96	96	0	0	0
Auxiliary lifting sheave	51	46	46	-14	-14	-14
40 ton (36.3mt) 1 sheave hook block at front bumper	658	516	516	-125	-125	-125
66 ton (60mt) 3 sheave hook block at front bumper	862	676	676	-164	-164	-164
100 ton (91mt) 5 sheave hook block at front bumper	1 021	801	801	-194	-194	-194
140 ton (127mt) 7 sheave hook block at front bumper	1 293	1 014	1 014	-245	-245	-245
200 ton (181mt) 10 sheave hook block at front bumper	1 451	1 139	1 139	-275	-275	-275
12 ton (10.9mt) hookball at front bumper	327	257	257	-62	-62	-62

⁽¹⁾ Adjust gross vehicle weight and axle loading according to component weight. All weights are $\pm 3\%$.

Tire	Maximum Axle Load @ 80.5kph Average Speed
20.5R25 (525/80R25) on aluminum disc wheels	12 702.4kg
16.00R25 (445/95R25) on aluminum disc wheels	13 255.8kg

Axle Loads with 2–Axle or 3–Axle Boom Dolly (3rd Axle Down) – English

Base crane with full tanks of fuel and no counterweight	Gross Vehicle Weight ⁽¹⁾	Axle 1	Axle 2	Axle 3	Axle 4	Axle 5	Dolly
	lb	lb	lb	lb	lb	lb	lb
	134,077	20,628	20,176	21,692	22,376	22,191	27,015
Nelson 2 - axle boom dolly ⁽²⁾	6,600	0	0	0	0	0	6,600
Nelson 3 - axle boom dolly ⁽²⁾	9,400	0	0	0	0	0	9,400
Driver in carrier cab	250	177	177	-34	-34	-34	0
Remove pontoons	-431	-15	-15	-134	-134	-134	0
Ether injector	5	4	4	-1	-1	-1	0
Rear pintle hook	44	-13	-13	23	23	23	0
16.00R25 (445/95R25) tires (instead of standard)	-1,008	-202	-202	-202	-202	-202	0
Carrier cab strobe light	5	4	4	-1	-1	-1	0
Hoist drum follower - main	96	30	30	12	12	12	0
Auxiliary winch with 725 ft (221m) of 7/8" (22mm) wire rope	3,205	1,168	1,168	290	290	290	0
Remove auxiliary winch with 725 ft (221m) of 7/8" (22mm) wire rope	-2,923	-1,089	-1,089	-248	-248	-248	0
Hoist drum follower - auxiliary	96	41	41	4	4	4	0
Remove 950 ft (289.5m) of wire rope from front (main) winch	-1,454	-416	-416	-207	-207	-207	0
Remove 725 ft (221m) of wire rope from rear (auxiliary) winch	-1,109	-365	-365	-126	-126	-126	0
Substitute 725 ft (221m) of rope with 950 ft (289.5m) of rope - rear (auxiliary)	344	113	113	39	39	39	0
Substitute 950 ft (289.5m) of rope with 725 ft (221m) of rope - front (main)	-344	-98	-98	-49	-49	-49	0
360° mechanical swing lock	151	60	60	10	10	10	0
Boom launching option	77	-10	-10	32	32	32	0
Floodlight to the front of the boom base section	7	0	0	0	0	0	7
Fly mounting brackets to boom base section for fly options	298	21	21	16	16	16	210
12 ft (3.65m) manual and hydraulically offsettable, lattice fly - stowed	2,340	-30	-30	-23	-23	-23	2,469
12-40 ft (3.65-12.2m) manual and hydraulically offsettable, two-piece (bi-fold) lattice fly - stowed	3,879	145	145	110	110	110	3,260
12-40-67 ft (3.65-12.2-20.4m) manual and hydraulically offsettable, three-piece (bi-fold) lattice fly - stowed	5,062	300	300	227	227	227	3,782
Additional components for hydraulically offsettable fly	422	23	23	17	17	17	326
Auxiliary lifting sheave	112	-6	-6	-5	-5	-5	139
40 ton (36.3mt) 1 sheave hook block at boom head	1,450	-67	-67	-51	-51	-51	1,735
66 ton (60mt) 3 sheave hook block at boom head	1,900	-88	-88	-66	-66	-66	2,274
100 ton (91mt) 5 sheave hook block at boom head	2,250	-104	-104	-78	-78	-78	2,693
140 ton (127mt) 7 sheave hook block at boom head	2,850	-131	-131	-99	-99	-99	3,411
12 ton (10.9mt) hookball at boom head	722	-33	-33	-25	-25	-25	864

⁽¹⁾ Adjust gross vehicle weight and axle loading according to component weight. All weights are ±3%.

⁽²⁾ Weights may vary.

Tire	Maximum Axle Load @ 50 mph Average Speed
20.5R25 (525/80R25) on aluminum disc wheels	28,004 lb
16.00R25 (445/95R25) on aluminum disc wheels	29,224 lb

Axle Loads with 2–Axle or 3–Axle Boom Dolly (3rd Axle Down) – Metric

Base crane with full tanks of fuel and no counterweight	Gross Vehicle Weight ⁽¹⁾	Axle 1	Axle 2	Axle 3	Axle 4	Axle 5	Dolly
	kg	kg	kg	kg	kg	kg	kg
	60 816	9 357	9 152	9 839	10 149	10 065	12 254
Nelson 2 - axle boom dolly ⁽²⁾	994	0	0	0	0	0	2 994
Nelson 2 - axle boom dolly ⁽²⁾	4 264	0	0	0	0	0	4 264
Driver in carrier cab	113	80	80	-15	-15	-15	0
Remove pontoons	-195	-7	-7	-61	-61	-61	0
Ether injector	2	2	2	0	0	0	0
Rear pintle hook	20	-6	-6	10	10	10	0
16.00R25 (445/95R25) tires (instead of standard)	-457	-92	-92	-92	-92	-92	0
Carrier cab strobe light	2	2	2	0	0	0	0
Hoist drum follower - main	44	14	14	5	5	5	0
Auxiliary winch with 725 ft (221m) of 7/8" (22mm) wire rope	1 454	530	530	131	131	131	0
Remove auxiliary winch with 725 ft (221m) of 7/8" (22mm) wire rope	-1 326	-494	-494	-112	-112	-112	0
Hoist drum follower - auxiliary	44	19	19	2	2	2	0
Remove 950 ft (289.5m) of wire rope from front (main) winch	-660	-189	-189	-94	-94	-94	0
Remove 725 ft (221m) of wire rope from rear (auxiliary) winch	-503	-166	-166	-57	-57	-57	0
Substitute 725 ft (221m) of rope with 950 ft (289.5m) of rope - rear (auxiliary)	156	51	51	18	18	18	0
Substitute 950 ft (289.5m) of rope with 725 ft (221m) of rope - front (main)	-156	-44	-44	-22	-22	-22	0
360° mechanical swing lock	68	27	27	5	5	5	0
Boom launching option	35	-5	-5	15	15	15	0
Floodlight to the front of the boom base section	3	0	0	0	0	0	3
Fly mounting brackets to boom base section for fly options	135	10	10	7	7	7	95
12 ft (3.65m) manual and hydraulically offsettable, lattice fly - stowed	1 061	-14	-14	-10	-10	-10	1 120
12-40 ft (3.65-12.2m) manual and hydraulically offsettable, two-piece (bi-fold) lattice fly - stowed	1 759	66	66	50	50	50	1 479
12-40-67 ft (3.65-12.2-20.4m) manual and hydraulically offsettable, three-piece (bi-fold) lattice fly - stowed	2 296	136	136	103	103	103	1 715
Additional components for hydraulically offsettable fly	192	10	10	8	8	8	148
Auxiliary lifting sheave	51	-3	-3	-2	-2	-2	63
40 ton (36.3mt) 1 sheave hook block at boom head	658	30	30	23	23	23	787
66 ton (60mt) 3 sheave hook block at boom head	862	-40	-40	-30	-30	-30	1 031
100 ton (91mt) 5 sheave hook block at boom head	1 021	-47	-47	-35	-35	-35	1 222
140 ton (127mt) 7 sheave hook block at boom head	1 293	-59	-59	-45	-45	-45	1 547
12 ton (10.9mt) hookball at boom head	327	-15	-15	-11	-11	-11	392

⁽¹⁾ Adjust gross vehicle weight and axle loading according to component weight. All weights are $\pm 3\%$.

⁽²⁾ Weights may vary.

Tire	Maximum Axle Load @ 80.5kph Average Speed
20.5R25 (525/80R25) on aluminum disc wheels	12 702.4kg
16.00R25 (445/95R25) on aluminum disc wheels	13 255.8kg

General Dimensions

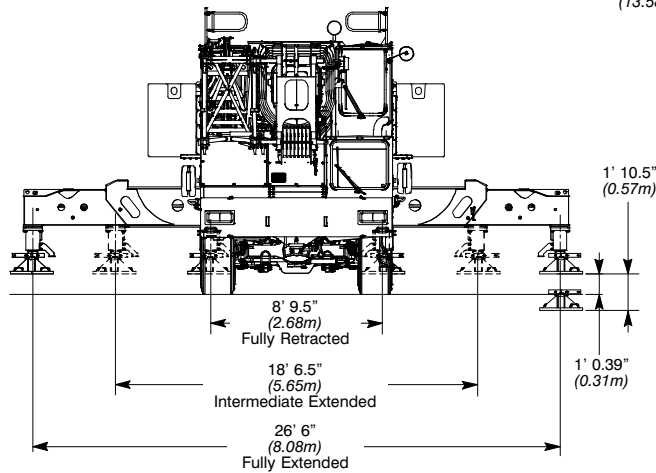
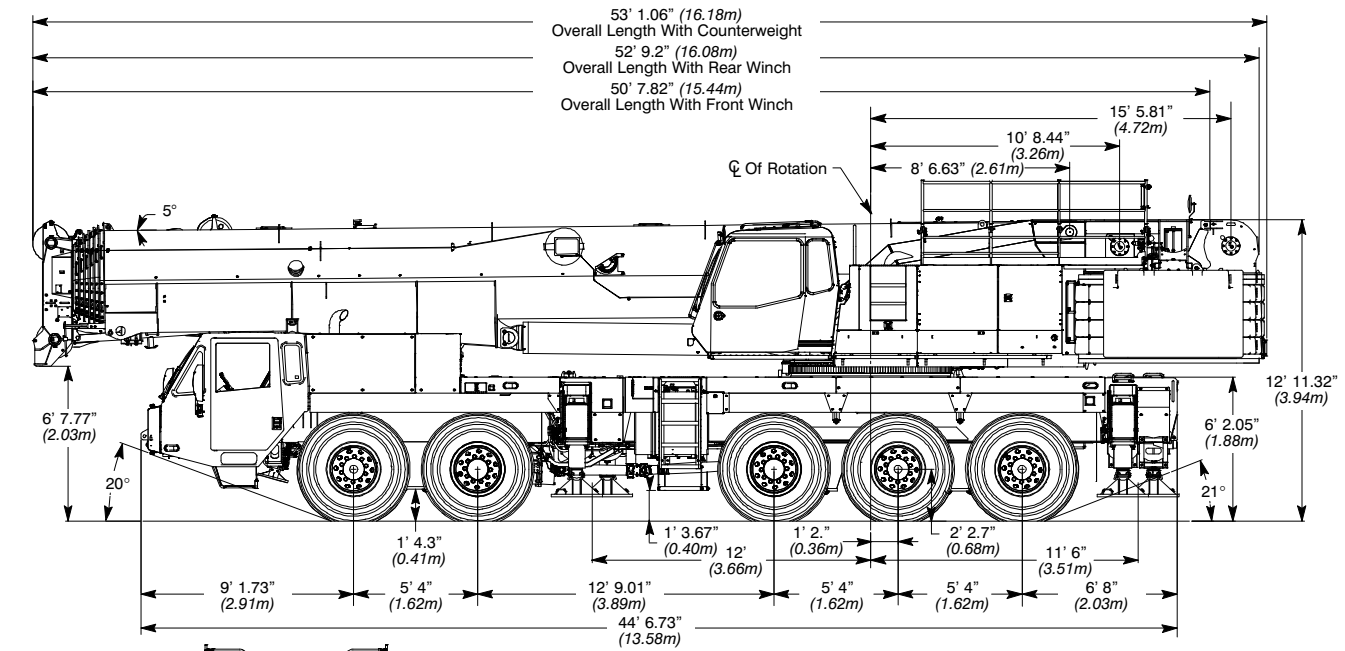

Turning Radius	20.5R25		16.00R25	
	English	Metric	English	Metric
Wall to wall over carrier	42' 0"	12.8m	41' 6"	12.6m
Wall to wall over boom	42' 6"	12.9m	42' 2"	12.8m
Wall to wall over boom attachment	44' 11"	13.7m	44' 6"	13.5m
Curb to curb	37' 1"	11.3m	36' 3"	11.04m
Centerline of tire	36' 2"	11.0m	35' 6"	10.8m

Tail Swing	English	Metric
With auxiliary winch	16' 11"	5.1m
Without auxiliary winch	14' 8"	4.7m
With Counterweight	17' 1"	5.21m

Overall Width	English	Metric
With 14,000 lb (6 350kg) counterweight	9' 10"	3.0m
With 36,000-115,000 lb (16 329-52 390kg) counterweight	10' 3"	3.1m
With 156,500 lb (70 987kg) counterweight	15' 2"	4.6m

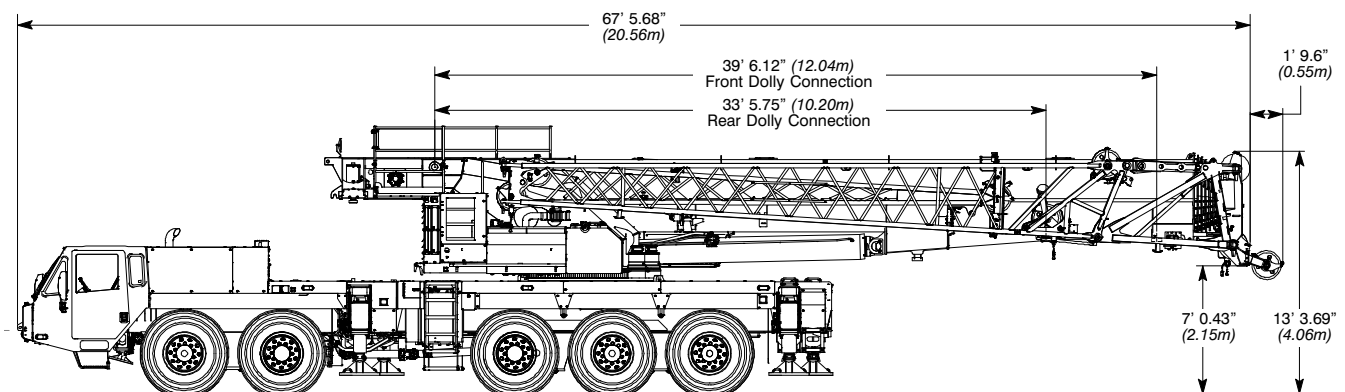

Not To Scale

Boom Extend Modes

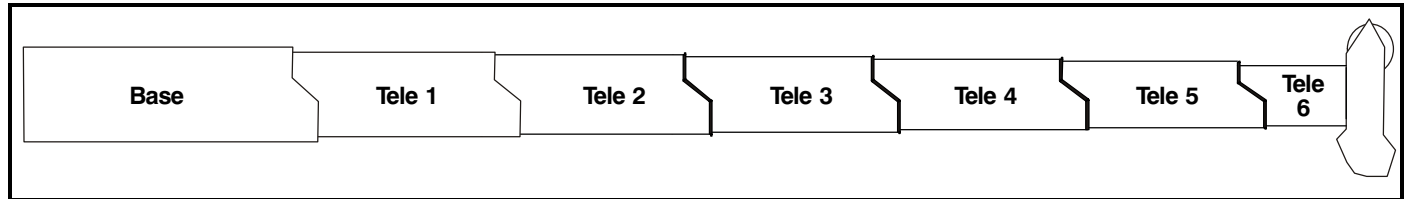

EM1 ALL SECTIONS EXTEND 100%							
Boom Length		Telescope Length					
ft	m	T6	T5	T4	T3	T2	T1
43.7	13.3						
71.1	21.7	100%					
99.6	30.3	100%	100%	0%			
128.9	39.3	100%	100%	100%	0%		
159.3	48.5	100%	100%	100%	100%	0%	
190.5	58.1	100%	100%	100%	100%	100%	0%
206.8	63.0	100%	100%	100%	100%	100%	50%
223	68.0	100%	100%	100%	100%	100%	100%

EM2 T6 50%, OTHERS 100%							
Boom Length		Telescope Length					
ft	m	T6	T5	T4	T3	T2	T1
43.7	13.3						
57.4	17.5	50%	0%	0%			
85.8	26.2	50%	100%	0%	0%		
115.2	35.1	50%	100%	100%	0%	0%	
145.5	44.4	50%	100%	100%	100%	0%	0%
176.8	53.9	50%	100%	100%	100%	100%	0%
193.1	58.8	50%	100%	100%	100%	100%	50%
209.3	63.8	50%	100%	100%	100%	100%	100%

EM3 T2,T3,T4 50%, OTHERS 100%							
Boom Length		Telescope Length					
ft	m	T6	T5	T4	T3	T2	T1
43.7	13.3						
71.1	21.7	100%	0%	0%	0%	0%	
99.5	30.3	100%	100%	0%	0%	0%	
114.2	34.8	100%	100%	50%	0%	0%	
129.4	39.4	100%	100%	50%	50%	0%	0%
145.0	44.2	100%	100%	50%	50%	50%	0%
161.3	49.2	100%	100%	50%	50%	50%	50%
177.5	54.1	100%	100%	50%	50%	50%	100%

EM4 T6,T1 100%, OTHERS 50%							
Boom Length		Telescope Length					
ft	m	T6	T5	T4	T3	T2	T1
43.7	13.3						
71.1	21.7	100%	0%	0%	0%	0%	
85.3	26.0	100%	50%	0%	0%	0%	
100.0	30.5	100%	50%	50%	0%	0%	
115.2	35.1	100%	50%	50%	50%	0%	0%
130.8	39.9	100%	50%	50%	50%	50%	0%
147.1	44.8	100%	50%	50%	50%	50%	50%
163.3	49.8	100%	50%	50%	50%	50%	100%

EM5 ALL SECTIONS 50%							
Boom Length		Telescope Length					
ft	m	T6	T5	T4	T3	T2	T1
43.7	13.3						
57.4	17.5	50%	0%				
71.6	21.8	50%	50%	0%			
86.3	26.3	50%	50%	50%	0%		
101.5	30.9	50%	50%	50%	50%	0%	
117.1	35.7	50%	50%	50%	50%	50%	0%
133.4	40.6	50%	50%	50%	50%	50%	50%

EM6 T6, RETRACTED, T1 100%, OTHERS 50%							
Boom Length		Telescope Length					
ft	m	T6	T5	T4	T3	T2	T1
43.7	13.3						
57.9	17.7	0%	50%	0%			
72.6	22.1	0%	50%	50%	0%		
87.8	26.7	0%	50%	50%	50%	0%	
103.4	31.5	0%	50%	50%	50%	50%	0%
119.6	36.5	0%	50%	50%	50%	50%	50%
135.9	41.4	0%	50%	50%	50%	50%	100%

EM7 T6,T5 RETRACTED, OTHERS 50%							
Boom Length		Telescope Length					
ft	m	T6	T5	T4	T3	T2	T1
43.7	13.3						
58.4	17.8	0%	0%	50%	0%	0%	0%
73.5	22.4	0%	0%	50%	50%	0%	0%
89.2	27.2	0%	0%	50%	50%	50%	0%
105.4	32.1	0%	0%	50%	50%	50%	50%

EM8 T6, T5, T4 RETRACTED, OTHERS 50%							
Boom Length		Telescope Length					
ft	m	T6	T5	T4	T3	T2	T1
43.7	13.3						
58.9	17.9	0%	0%	0%	50%	0%	0%
74.5	22.7	0%	0%	0%	50%	50%	0%
90.7	27.7	0%	0%	0%	50%	50%	50%

Working Range Diagram – Main Boom

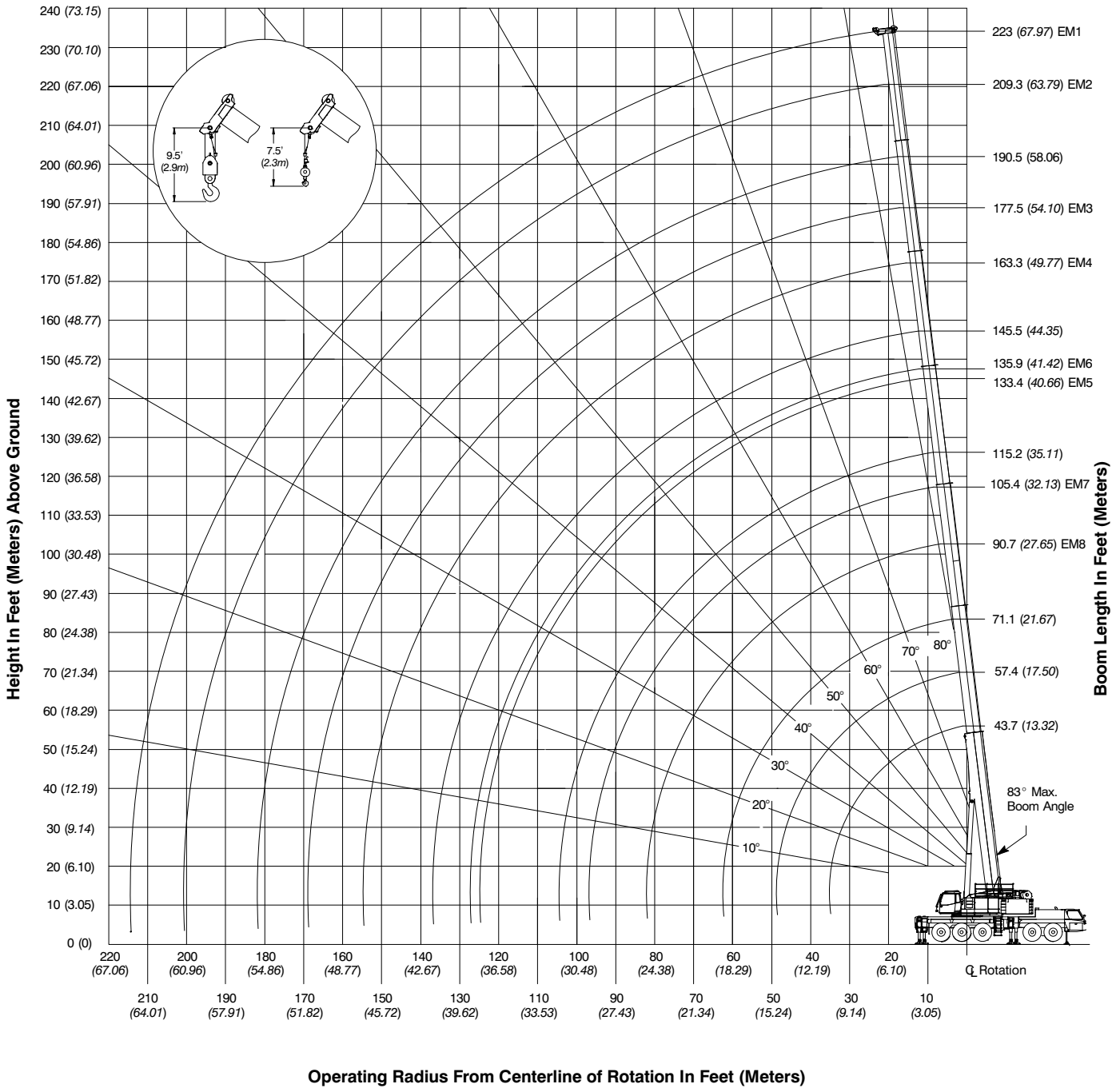

Main Boom Lift Capacity Charts – Standard

0 lb Counterweight - Fully Extended Outriggers - 360° Rotation (All Capacities Are Listed In Pounds)										
Radius (ft)	Boom Length (ft)									Radius (ft)
	43.7	57.4-58.9	71.1-74.5	85.3-90.7	99.6-105.4	114.2-119.7	128.9-135.9	145-147.1	159.3-161.3	
10	324,000	303,000	268,900	225,200						10
12	290,800	293,400	268,900	225,200						12
15	237,700	242,400	241,600	211,500	170,500					15
20	147,000	154,400	156,500	156,100	153,900	142,800	102,900			20
25	99,700	108,800	112,900	114,300	113,900	110,000	102,900	84,500	66,000	25
30	62,900	72,100	77,200	77,400	80,200	79,400	77,500	74,600	66,000	30
35	42,600	51,600	56,100	58,200	58,700	59,900	59,200	57,500	55,000	35
40		38,500	42,900	44,800	46,200	46,500	46,600	44,300	42,000	40
45		29,500	33,900	35,600	36,900	37,100	37,300	35,000	36,200	45
50		18,900	27,200	29,000	30,300	30,500	30,700	28,600	29,600	50
55			22,000	24,000	25,100	25,300	25,500	23,500	24,500	55
60			18,000	19,900	21,100	21,300	21,400	19,500	20,500	60
65			7,400	16,700	17,800	18,000	18,100	16,400	17,200	65
70				13,900	15,300	15,500	15,600	13,800	14,800	70
75				11,700	12,900	13,200	13,400	11,500	12,500	75
80				3,100	11,000	11,300	11,500	9,700	10,600	80
85					9,300	9,600	9,800	8,000	9,000	85
90					7,900	8,100	8,400	6,600	7,500	90
95						6,800	7,100	5,400	6,300	95
100						5,700	5,900	4,300	5,200	100
105						4,800	4,900	3,300	4,200	105
110							4,000	2,400	3,300	110
115							3,200		2,500	115
120							2,500			120

Note: Capacities depict multiple boom modes.

This information is not for crane operation. Operator must refer to the in-cab information for crane operation. Rated lifting capacities shown on fully extended outriggers do not exceed 85% of the tipping loads.

36,000 lb Counterweight - Fully Extended Outriggers - 360° Rotation (All Capacities Are Listed In Pounds)														
Radius (ft)	Boom Length (ft)												Radius (ft)	
	43.7	57.4-58.9	71.1-74.5	85.3-90.7	99.6-105.4	114.2-119.7	128.9-135.9	145-147.1	159.3-163.3	176.8-177.5	190.5-193.1	206.8-209.3		223
10	331,300	303,000	268,900	225,200										10
12	297,500	299,900	268,900	225,200										12
15	257,100	260,200	252,900	211,500	170,500									15
20	193,000	200,100	199,100	196,900	170,500	142,800	102,900							20
25	135,900	142,900	145,300	145,100	143,300	140,300	119,000	84,500	70,200					25
30	102,600	110,400	114,000	115,000	114,400	110,000	106,000	84,500	70,200	55,200	35,500			30
35	78,500	86,900	90,100	91,100	90,800	89,200	86,800	84,500	70,200	55,200	45,600	34,300		35
40		68,300	71,600	72,600	72,300	72,200	72,600	70,300	68,700	55,200	45,600	36,700	30,100	40
45		54,700	58,100	59,100	61,200	60,600	59,200	57,800	58,000	55,200	45,600	36,700	30,100	45
50		40,700	49,000	50,800	51,200	50,700	50,700	50,200	48,200	47,200	45,600	36,700	30,100	50
55			41,200	43,100	43,500	43,500	43,800	42,500	40,500	40,400	38,900	36,700	30,100	55
60			35,100	37,000	37,400	38,300	37,700	36,400	36,400	34,400	35,400	34,300	30,100	60
65			22,900	32,100	33,400	33,500	33,700	31,700	32,700	29,900	30,800	29,500	28,300	65
70				28,000	29,300	29,500	29,600	27,700	28,700	25,900	26,800	25,500	24,300	70
75				24,600	25,900	26,100	26,200	24,400	25,300	22,500	23,500	22,100	21,000	75
80				15,200	22,900	23,200	23,300	21,500	22,400	19,700	20,600	19,300	18,200	80
85					20,400	20,700	20,800	19,000	19,900	17,200	18,200	17,200	16,100	85
90					18,300	18,500	18,700	17,100	17,800	15,400	16,300	15,000	14,000	90
95					7,400	16,700	16,900	15,200	16,100	13,500	14,400	13,200	12,100	95
100						15,000	15,200	13,500	14,400	11,900	12,800	11,500	10,500	100
105							13,500	13,700	12,100	12,900	10,400	11,300	10,100	105
110							5,000	12,300	10,700	11,600	9,100	10,000	8,700	110
115								11,100	9,500	10,400	7,900	8,800	7,600	115
120								10,000	8,400	9,300	6,800	7,700	6,500	120
125									7,400	8,300	5,800	6,700	5,500	125
130									6,500	7,400	4,900	5,800	4,600	130
135									5,700	6,500	4,100	5,000	3,800	135
140										5,700	3,300	4,200	3,100	140
145										5,000	2,600	3,500	2,400	145
150										4,400		2,900		150
155											2,200			155

Note: Capacities depict multiple boom modes.

This information is not for crane operation. Operator must refer to the in-cab information for crane operation. Rated lifting capacities shown on fully extended outriggers do not exceed 85% of the tipping loads.

Main Boom Lift Capacity Charts – Optional

80,000 lb Counterweight - Fully Extended Outriggers - 360° Rotation (All Capacities Are Listed In Pounds)														
Radius (ft)	Boom Length (ft)												Radius (ft)	
	43.7	57.4-58.9	71.1-74.5	85.3-90.7	99.6-105.4	114.2-119.7	128.9-135.9	145-147.1	159.3-163.3	176.8-177.5	190.5-193.1	206.8-209.3		223
10	337,700	303,000	268,900	225,200										10
12	305,400	302,400	268,900	225,200										12
15	264,300	267,100	252,900	211,500	170,500									15
20	214,100	217,600	215,200	211,500	170,500	142,800	102,900							20
25	172,100	177,100	176,900	176,000	168,800	142,800	119,000	84,500	70,200					25
30	135,300	142,300	142,100	140,800	143,000	140,100	113,200	84,500	70,200	55,200	35,500			30
35	107,500	114,100	116,700	117,100	115,600	113,200	102,900	84,500	70,200	55,200	45,600	34,300		35
40		95,300	96,800	97,300	96,200	98,200	95,900	79,300	70,200	55,200	45,600	36,700	30,100	40
45		80,500	83,900	85,100	85,000	83,700	81,500	74,300	70,200	55,200	45,600	36,700	30,100	45
50		65,200	72,300	73,500	73,300	72,000	70,000	69,900	66,000	55,200	45,600	36,700	30,100	50
55			62,400	63,600	63,300	62,100	62,500	61,600	60,000	54,800	45,600	36,700	30,100	55
60			54,300	55,400	55,200	54,700	55,500	53,500	52,000	52,000	44,800	36,700	30,100	60
65			41,400	48,800	48,800	50,400	49,100	47,200	47,700	46,600	42,200	36,700	30,100	65
70				43,400	44,200	44,900	43,700	42,700	42,700	41,200	39,500	36,700	30,100	70
75				38,800	40,600	40,300	39,100	39,800	38,100	36,600	36,700	35,500	30,100	75
80				29,800	36,600	36,300	35,200	35,900	34,400	33,600	33,100	34,000	30,100	80
85					33,300	33,000	33,100	32,700	31,000	30,900	30,500	30,500	29,400	85
90					30,400	30,000	30,800	29,700	28,000	27,900	28,800	27,500	26,400	90
95					19,400	27,300	28,200	27,000	25,300	25,300	26,200	24,900	23,800	95
100						25,400	25,800	24,700	23,000	22,900	23,800	22,600	21,500	100
105						24,200	23,600	22,600	20,900	20,900	21,700	20,500	19,400	105
110						15,100	21,800	20,700	19,700	19,000	19,900	18,600	17,500	110
115							20,100	19,000	18,700	17,300	18,200	16,900	16,200	115
120							18,600	17,400	17,800	16,000	16,900	15,700	14,700	120
125							9,400	16,200	16,900	14,600	15,500	14,300	13,300	125
130								14,900	15,800	13,400	14,200	13,000	12,000	130
135								13,700	14,600	12,200	13,100	11,900	10,900	135
140									13,500	11,100	12,000	10,800	9,800	140
145									12,500	10,100	11,000	9,800	8,800	145
150									11,600	9,100	10,000	8,900	7,900	150
155										8,300	9,200	8,000	7,000	155
160										7,500	8,400	7,200	6,300	160
165										6,800	7,600	6,500	5,500	165
170											6,900	5,800	4,800	170
175											6,300	5,100	4,200	175
180											5,700	4,500	3,500	180
185												3,900	3,000	185
190												3,400	2,400	190

Note: Capacities depict multiple boom modes.

This information is not for crane operation. Operator must refer to the in-cab information for crane operation. Rated lifting capacities shown on fully extended outriggers do not exceed 85% of the tipping loads.

102,000 lb Counterweight - Fully Extended Outriggers - 360° Rotation (All Capacities Are Listed In Pounds)														
Radius (ft)	Boom Length (ft)												Radius (ft)	
	43.7	57.4-58.9	71.1-74.5	85.3-90.7	99.6-105.4	114.2-119.7	128.9-135.9	145-147.1	159.3-163.3	176.8-177.5	190.5-193.1	206.8-209.3		223
10	340,300	303,000	268,900	225,200										10
12	307,900	302,400	268,900	225,200										12
15	267,900	269,800	252,900	211,500	170,500									15
20	217,100	220,600	218,100	211,500	170,500	142,800	102,900							20
25	181,200	185,000	184,300	183,900	168,800	142,800	119,000	84,500	70,200					25
30	148,300	153,500	153,400	152,700	150,800	142,800	113,200	84,500	70,200	55,200	35,500			30
35	121,500	128,200	128,300	127,400	129,600	126,900	102,900	84,500	70,200	55,200	45,600	34,300		35
40		105,900	108,400	108,800	107,700	105,400	102,900	79,300	70,200	55,200	45,600	36,700	30,100	40
45		90,700	92,100	92,600	91,600	93,700	91,400	74,300	70,200	55,200	45,600	36,700	30,100	45
50		74,200	79,600	80,000	81,200	81,200	79,100	69,900	66,000	55,200	45,600	36,700	30,100	50
55			71,200	72,400	72,200	71,100	69,100	66,000	61,200	54,800	45,600	36,700	30,100	55
60			63,000	64,100	64,100	63,000	61,100	62,300	56,800	52,000	44,800	36,700	30,100	60
65			49,400	57,200	57,100	56,000	55,800	55,600	53,000	49,400	42,200	36,700	30,100	65
70				51,200	51,100	50,100	51,500	49,600	48,100	46,800	39,500	36,700	30,100	70
75				46,000	45,900	46,300	46,300	44,500	43,100	43,800	37,400	36,700	30,100	75
80				36,500	41,400	43,000	41,800	40,000	40,900	39,400	35,500	34,900	30,100	80
85					37,800	39,100	38,000	36,300	37,000	35,600	33,700	32,800	30,100	85
90					36,200	35,700	34,600	34,600	33,900	32,500	32,100	30,900	30,100	90
95					25,000	32,800	31,800	32,600	31,000	29,600	29,700	29,300	29,200	95
100						30,200	29,100	30,000	28,400	27,200	27,100	27,900	26,900	100
105						27,900	27,300	27,600	26,000	25,900	24,800	25,600	24,500	105
110						20,000	26,100	25,500	23,900	23,900	23,700	23,500	22,500	110
115							24,600	23,600	22,000	22,000	22,600	21,600	20,600	115
120							23,000	21,800	20,300	20,300	21,100	19,900	18,900	120
125							13,700	20,300	18,700	18,700	19,600	18,400	17,300	125
130								18,900	17,300	17,300	18,100	17,000	16,200	130
135								17,600	16,100	16,100	17,000	15,900	14,900	135
140									14,900	14,900	15,800	14,600	13,700	140
145									13,900	13,700	14,600	13,500	12,500	145
150									13,300	12,700	13,600	12,500	11,500	150
155										11,700	12,600	11,500	10,500	155
160										10,800	11,700	10,600	9,600	160
165										10,000	10,800	9,700	8,700	165
170											10,000	8,900	7,900	170
175											9,300	8,200	7,100	175
180											8,600	7,400	6,300	180
185												6,700	5,600	185
190												6,000	4,900	190
195												3,400	4,300	195
200												2,800	3,700	200
205													3,200	205

Note: Capacities depict multiple boom modes.

This information is not for crane operation. Operator must refer to the in-cab information for crane operation. Rated lifting capacities shown on fully extended outriggers do not exceed 85% of the tipping loads.

156,500 lb Counterweight - Fully Extended Outriggers - 360° Rotation (All Capacities Are Listed In Pounds)															
Radius (ft)	Boom Length (ft)												Radius (ft)		
	43.7	57.4-58.9	71.1-74.5	85.3-90.7	99.6-105.4	114.2-119.7	128.9-135.9	145-147.1	159.3-163.3	176.8-177.5	190.5-193.1	206.8-209.3		223	
8	550,000*													8	
10	350,000	303,000	268,900	225,200										10	
12	313,900	302,400	268,900	225,200										12	
15	274,100	275,700	252,900	211,500	170,500									15	
20	224,600	226,900	225,300	211,500	170,500	142,800	102,900							20	
25	187,500	191,300	189,000	190,100	168,800	142,800	119,000	84,500	70,200					25	
30	159,900	163,900	162,700	163,000	159,400	142,800	113,200	84,500	70,200	55,200	35,500			30	
35	138,500	142,700	142,600	142,000	140,500	141,800	102,900	84,500	70,200	55,200	45,600	34,300		35	
40		125,900	125,900	125,300	124,000	125,200	102,900	79,300	70,200	55,200	45,600	36,700	30,100	40	
45		110,100	110,100	109,600	111,500	109,700	102,900	74,300	70,200	55,200	45,600	36,700	30,100	45	
50		94,800	97,300	96,800	98,700	97,000	96,100	69,900	66,000	55,200	45,600	36,700	30,100	50	
55			88,600	86,200	88,100	86,500	88,100	66,000	61,200	54,800	45,600	36,700	30,100	55	
60			79,800	80,100	79,300	78,000	79,400	62,300	56,800	52,000	44,800	36,700	30,100	60	
65			66,300	71,700	70,800	72,900	71,000	59,100	53,000	49,400	42,200	36,700	30,100	65	
70				64,500	63,700	65,800	63,900	56,300	49,500	46,800	39,500	36,700	30,100	70	
75				58,400	57,700	59,600	57,800	53,700	46,400	43,900	37,400	36,700	30,100	75	
80				50,200	54,500	54,300	52,400	51,400	43,500	41,300	35,500	34,900	30,100	80	
85					50,900	49,800	48,000	49,200	41,000	39,000	33,700	32,800	30,100	85	
90					46,900	45,700	44,000	45,500	38,700	36,800	32,100	30,900	30,100	90	
95					36,400	42,100	42,200	41,900	36,500	34,800	30,600	29,300	29,200	95	
100							38,900	40,500	38,600	34,600	32,900	29,200	27,900	27,600	100
105							36,100	37,600	35,700	32,900	31,200	27,800	26,700	26,100	105
110							29,800	34,900	33,300	31,600	29,700	26,600	25,500	24,700	110
115								32,700	30,900	30,400	28,200	25,500	24,300	23,400	115
120								29,400	28,700	29,300	26,800	24,400	23,300	22,200	120
125								22,000	26,700	27,600	25,500	23,200	22,300	21,000	125
130									24,900	25,800	24,300	22,000	21,400	20,000	130
135									23,300	24,100	22,700	21,000	20,400	19,000	135
140										22,600	21,200	19,900	19,600	18,000	140
145										21,200	19,700	19,000	18,800	17,100	145
150										19,800	18,400	18,100	18,100	16,300	150
155											17,300	17,200	17,400	15,500	155
160											16,100	16,200	16,600	14,800	160
165											15,000	15,100	15,900	14,000	165
170												14,100	15,000	13,400	170
175												13,200	14,000	12,700	175
180												12,700	13,100	12,100	180
185													12,300	11,200	185
190													11,500	10,400	190
195													8,700	9,600	195
200													7,800	8,900	200
205														8,200	205

Note: Capacities depict multiple boom modes.
 * Over rear intermediate outriggers additional equipment required.

This information is not for crane operation. Operator must refer to the in-cab information for crane operation. Rated lifting capacities shown on fully extended outriggers do not exceed 85% of the tipping loads.

Working Range Diagram – Main Boom + Fly

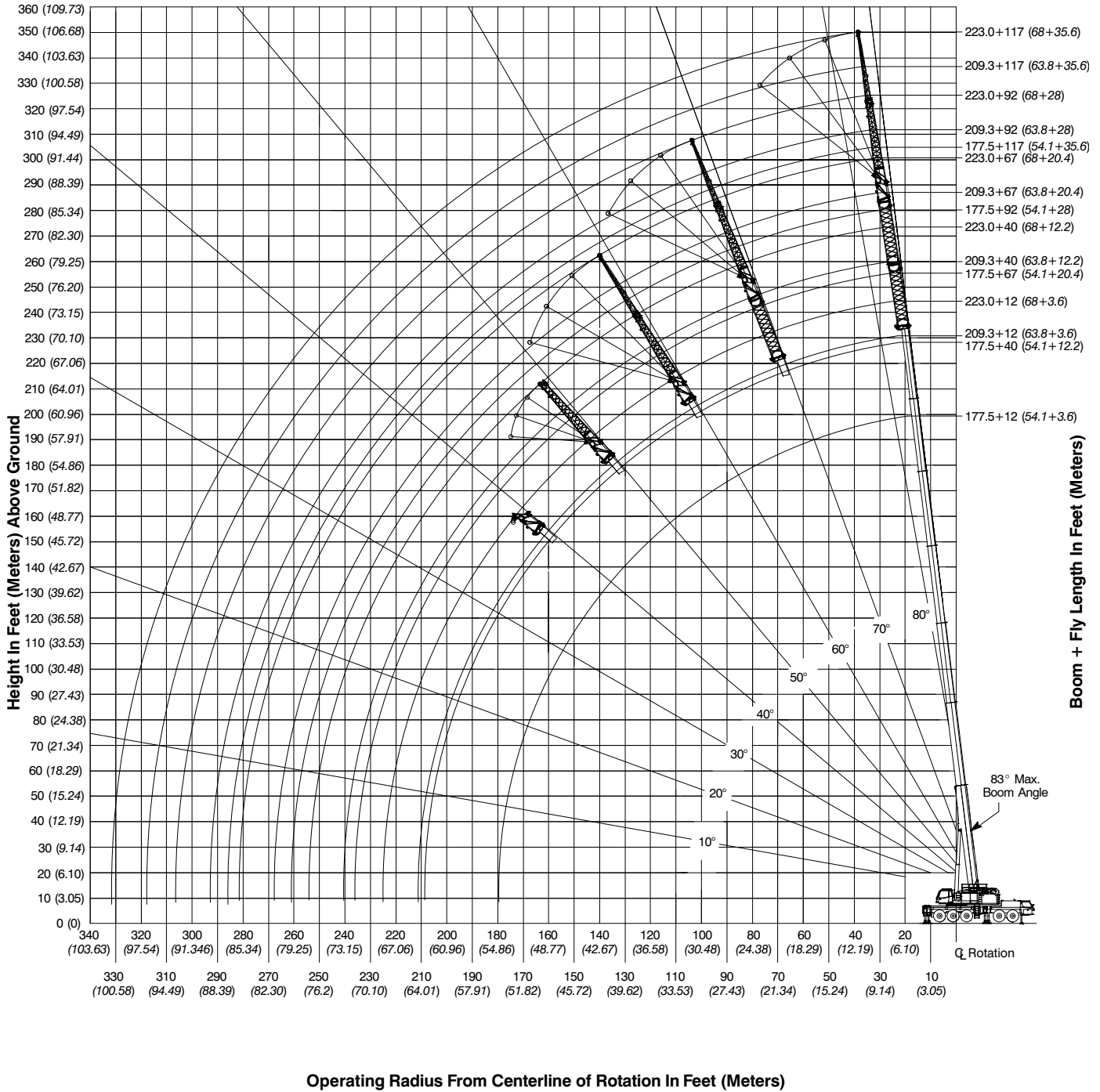

Manual & Hydraulic Offset Fly Attachment Lift Capacity Charts – Optional

36,000 lb Counterweight - Fully Extended Outriggers - 360° Rotation (All Capacities Are Listed In Pounds)															
Main Boom + 12 ft Offset Fly (Manual Offsets 2°, 15°, 30°, 45° & Hydraulic Offsets 2° - 45°)															
Boom Length (ft)															
Radius (ft)	43.7		57.4 – 58.8		71.1 – 74.4		85.3 – 90.7		99.5 – 105.4		114.2 – 119.6		128.9 – 135.9		Radius (ft)
	2°–4°	4°–45°	2°–4°	4°–45°	2°–4°	4°–45°	2°–4°	4°–45°	2°–4°	4°–45°	2°–4°	4°–45°	2°–4°	4°–45°	
10	69,600	69,600	69,600	69,600	69,500	69,500	69,400	69,400							10
12	69,600	69,600	69,600	69,600	69,500	69,500	69,400	69,400							12
15	69,600	69,600	69,600	69,600	69,500	69,500	69,400	69,400	69,300	69,300	69,200	69,200	69,100	69,100	15
20	69,600	69,600	69,600	69,600	69,500	69,500	69,400	69,400	69,300	69,300	69,200	69,200	69,100	69,100	20
25	69,600	69,600	69,600	69,600	69,500	69,500	69,400	69,400	69,300	69,300	69,200	69,200	69,100	69,100	25
30	69,600	69,600	69,600	69,600	69,500	69,500	69,400	69,400	69,300	69,300	69,200	69,200	69,100	69,100	30
35	69,600	66,700	69,600	69,600	69,500	69,500	69,400	69,400	69,300	69,300	69,200	69,200	69,100	69,100	35
40	66,800	61,000	69,600	69,500	69,500	69,500	69,400	69,400	69,300	69,300	69,200	69,200	68,100	68,000	40
45	53,600	53,600	57,200	57,200	58,900	58,900	59,300	59,300	58,500	58,500	60,000	57,700	58,300	58,300	45
50			47,400	47,400	49,000	49,000	49,300	49,300	50,800	49,400	50,000	50,000	48,500	48,500	50
55			39,900	39,900	41,400	41,400	42,300	41,600	43,100	43,100	42,300	42,300	42,900	42,000	55
60			32,200	32,200	36,100	36,100	37,000	37,000	37,000	37,000	37,100	36,300	36,800	36,800	60
65					31,400	31,400	32,200	32,200	32,200	32,200	32,800	32,800	32,100	32,100	65
70					27,500	27,500	28,200	28,200	28,900	28,800	28,800	28,800	28,700	28,700	70
75					20,200	20,200	24,900	24,900	25,500	25,500	25,400	25,400	25,300	25,300	75
80							22,100	22,100	22,600	22,600	22,500	22,500	22,400	22,400	80
85							19,700	19,700	20,200	20,200	20,000	20,000	19,900	19,900	85
90							11,800	11,800	18,000	18,000	17,900	17,900	17,800	17,800	90
95									16,300	16,300	16,200	16,200	16,100	16,100	95
100									14,700	14,700	14,500	14,500	14,400	14,400	100
105									8,300	8,300	13,000	13,000	12,900	12,900	105
110											11,700	11,700	11,600	11,600	110
115											10,600	10,600	10,400	10,400	115
120											2,900	2,900	9,400	9,400	120
125													8,400	8,400	125
130													7,600	7,600	130
135															135
140															140
145															145
150															150
155															155
160															160

Note: Capacities depict multiple boom modes.

This information is not for crane operation. Operator must refer to the in-cab information for crane operation. Rated lifting capacities shown on fully extended outriggers do not exceed 85% of the tipping loads.

**36,000 lb Counterweight - Fully Extended Outriggers - 360° Rotation
(All Capacities Are Listed In Pounds)**

Main Boom + 12 ft Offset Fly (Manual Offsets 2°, 15°, 30°, 45° & Hydraulic Offsets 2° - 45°)

Boom Length (ft)													
Radius (ft)	145 – 147		159.2 – 163.3		176.8 – 177.5		190.5 – 193.0		206.7 – 209.3		223		Radius (ft)
	2°–4°	4°–45°	2°–4°	4°–45°	2°–4°	4°–45°	2°–4°	4°–45°	2°–4°	4°–45°	2°–4°	4°–45°	
10													10
12													12
15													15
20	69,000	68,900	33,900	33,800									20
25	69,000	68,900	58,100	57,000	47,500	46,600	36,700	36,700					25
30	69,000	68,900	58,100	57,000	47,500	46,600	36,700	36,500	31,900	31,900			30
35	69,000	68,900	58,100	57,000	47,500	46,600	36,700	36,200	31,900	31,400	26,000	25,900	35
40	69,000	68,700	58,100	57,000	47,500	46,600	36,700	36,200	31,900	31,400	26,000	25,700	40
45	55,900	55,900	54,600	54,000	47,500	46,600	36,700	36,200	31,900	31,400	26,000	25,700	45
50	49,200	47,900	47,000	47,000	45,300	45,300	36,700	36,200	31,900	31,400	26,000	25,700	50
55	41,500	41,500	39,400	39,400	37,900	37,700	36,700	36,200	31,900	31,400	26,000	25,700	55
60	35,400	35,400	33,900	33,700	33,500	33,500	32,000	32,000	30,700	30,700	26,000	25,700	60
65	30,800	30,800	31,600	31,600	28,700	28,700	29,500	29,500	28,100	28,100	26,000	25,700	65
70	26,800	26,800	27,500	27,500	24,700	24,700	25,500	25,500	24,100	24,100	22,900	22,900	70
75	23,400	23,400	24,200	24,200	21,400	21,400	22,200	22,200	20,800	20,800	19,600	19,600	75
80	20,500	20,500	21,300	21,300	18,600	18,600	19,400	19,400	18,000	18,000	16,800	16,800	80
85	18,100	18,100	18,800	18,800	16,400	16,400	16,900	16,900	15,900	15,900	14,800	14,800	85
90	16,200	16,200	16,900	16,900	14,300	14,300	15,100	15,100	13,800	13,800	12,700	12,700	90
95	14,300	14,300	15,000	15,000	12,400	12,400	13,200	13,200	11,900	11,900	10,800	10,800	95
100	12,600	12,600	13,400	13,400	10,800	10,800	11,600	11,600	10,300	10,300	9,200	9,200	100
105	11,200	11,200	11,900	11,900	9,300	9,300	10,100	10,100	8,800	8,800	7,700	7,700	105
110	9,800	9,800	10,500	10,500	8,000	8,000	8,800	8,800	7,500	7,500	6,400	6,400	110
115	8,700	8,700	9,300	9,300	6,800	6,800	7,600	7,600	6,300	6,300	5,300	5,300	115
120	7,600	7,600	8,300	8,300	5,800	5,800	6,500	6,500	5,300	5,300	4,200	4,200	120
125	6,600	6,600	7,300	7,300	4,800	4,800	5,500	5,500	4,300	4,300	3,200	3,200	125
130	5,700	5,700	6,400	6,400	3,900	3,900	4,600	4,600	3,400	3,400	2,400	2,400	130
135	4,900	4,900	5,600	5,600	3,100	3,100	3,800	3,800	2,600	2,600			135
140	4,200	4,200	4,800	4,800	2,400	2,400	3,100	3,100					140
145	3,600	3,600	4,100	4,100			2,400	2,400					145
150			3,500	3,500									150
155			2,900	2,900									155
160			2,400	2,400									160

Note: Capacities depict multiple boom modes.

This information is not for crane operation. Operator must refer to the in-cab information for crane operation. Rated lifting capacities shown on fully extended outriggers do not exceed 85% of the tipping loads.

156,500 lb Counterweight - Fully Extended Outriggers - 360° Rotation (All Capacities Are Listed In Pounds)															
Main Boom + 12 ft Offset Fly (Manual Offsets 2°, 15°, 30°, 45° & Hydraulic Offsets 2° - 45°)															
Boom Length (ft)															
Radius (ft)	43.7		57.4 - 58.8		71.1 - 74.4		85.3 - 90.7		99.5 - 105.4		114.2 - 119.6		128.9 - 135.9		Radius (ft)
	2°-4°	4°-45°	2°-4°	4°-45°	2°-4°	4°-45°	2°-4°	4°-45°	2°-4°	4°-45°	2°-4°	4°-45°	2°-4°	4°-45°	
10	69,600	69,600	69,600	69,600	69,500	69,500	69,400	69,400							10
12	69,600	69,600	69,600	69,600	69,500	69,500	69,400	69,400							12
15	69,600	69,600	69,600	69,600	69,500	69,500	69,400	69,400	69,300	69,300	69,200	69,200	69,100	69,100	15
20	69,600	69,600	69,600	69,600	69,500	69,500	69,400	69,400	69,300	69,300	69,200	69,200	69,100	69,100	20
25	69,600	69,600	69,600	69,600	69,500	69,500	69,400	69,400	69,300	69,300	69,200	69,200	69,100	69,100	25
30	69,600	69,600	69,600	69,600	69,500	69,500	69,400	69,400	69,300	69,300	69,200	69,200	69,100	69,100	30
35	69,600	66,700	69,600	69,600	69,500	69,500	69,400	69,400	69,300	69,300	69,200	69,200	69,100	69,100	35
40	69,600	61,000	69,600	69,500	69,500	69,500	69,400	69,400	69,300	69,300	69,200	69,200	69,100	69,100	40
45	63,700	57,700	69,600	67,600	69,500	69,500	69,400	69,400	69,300	69,300	69,200	69,200	69,100	69,100	45
50			69,600	63,700	69,500	69,500	69,400	69,400	69,300	69,300	69,200	69,200	69,100	69,100	50
55			68,800	59,700	69,500	68,300	69,400	69,400	69,300	69,300	69,200	69,200	69,100	69,100	55
60			63,500	57,500	69,500	65,100	69,400	69,400	69,300	69,300	69,200	69,200	69,100	69,100	60
65					69,500	61,500	69,400	68,500	69,300	69,300	68,700	68,700	69,100	69,100	65
70					65,200	59,200	64,700	64,000	63,800	63,800	64,200	63,200	63,100	63,100	70
75					57,900	57,400	59,200	59,200	57,700	57,700	59,200	59,200	57,100	57,100	75
80							53,900	53,900	52,500	52,500	54,000	54,000	51,800	51,800	80
85							49,500	49,500	48,100	48,100	49,600	49,600	47,500	47,500	85
90							42,800	42,800	45,400	45,200	45,500	45,500	43,500	43,500	90
95									43,100	42,900	42,000	42,000	39,900	39,900	95
100									40,300	40,300	38,800	38,800	36,700	36,700	100
105									34,400	34,400	35,900	35,900	34,000	34,000	105
110											33,400	33,400	31,900	31,400	110
115											31,100	31,100	30,700	30,000	115
120											25,600	25,600	29,600	29,000	120
125													28,100	28,100	125
130													26,400	26,400	130
135													18,600	18,600	135
140															140
145															145
150															150
155															155
160															160
165															165
170															170
175															175
180															180
185															185
190															190
195															195
200															200
205															205
210															210
215															215
220															220

Note: Capacities depict multiple boom modes.

This information is not for crane operation. Operator must refer to the in-cab information for crane operation. Rated lifting capacities shown on fully extended outriggers do not exceed 85% of the tipping loads.

156,500 lb Counterweight - Fully Extended Outriggers - 360° Rotation (All Capacities Are Listed In Pounds)													
Main Boom + 12 ft Offset Fly (Manual Offsets 2°, 15°, 30°, 45° & Hydraulic Offsets 2° - 45°)													
Boom Length (ft)													
Radius (ft)	145 – 147		159.2 – 163.3		176.8 – 177.5		190.5 – 193.0		206.7 – 209.3		223		Radius (ft)
	2°–4°	4°–45°	2°–4°	4°–45°	2°–4°	4°–45°	2°–4°	4°–45°	2°–4°	4°–45°	2°–4°	4°–45°	
10													10
12													12
15													15
20	69,000	68,900	33,900	33,800									20
25	69,000	68,900	58,100	57,000	47,500	46,600	36,700	36,700					25
30	69,000	68,900	58,100	57,000	47,500	46,600	36,700	36,500	31,900	31,900			30
35	69,000	68,900	58,100	57,000	47,500	46,600	36,700	36,200	31,900	31,400	26,000	25,900	35
40	69,000	68,700	58,100	57,000	47,500	46,600	36,700	36,200	31,900	31,400	26,000	25,700	40
45	68,300	64,100	58,100	57,000	47,500	46,600	36,700	36,200	31,900	31,400	26,000	25,700	45
50	63,700	60,000	58,100	57,000	47,500	46,600	36,700	36,200	31,900	31,400	26,000	25,700	50
55	59,600	56,500	58,100	57,000	47,500	46,600	36,700	36,200	31,900	31,400	26,000	25,700	55
60	56,100	53,300	54,600	54,300	47,500	45,900	36,700	36,200	31,900	31,400	26,000	25,700	60
65	52,900	50,400	50,700	50,500	45,300	43,500	36,700	36,200	31,900	31,400	26,000	25,700	65
70	50,000	47,800	47,300	47,100	43,000	41,200	36,700	36,200	31,900	31,400	26,000	25,700	70
75	47,400	45,400	44,200	44,100	40,600	39,200	35,100	34,700	31,900	31,400	26,000	25,700	75
80	45,100	43,300	41,600	41,500	38,700	37,400	33,200	32,800	31,900	31,400	26,000	25,700	80
85	42,900	41,300	39,000	39,000	36,900	35,700	31,400	31,000	31,100	31,100	26,000	25,700	85
90	41,000	39,500	36,700	36,700	34,800	34,100	29,700	29,400	29,200	29,200	26,000	25,700	90
95	39,200	37,900	34,600	34,600	32,900	32,700	28,200	27,900	27,500	27,500	26,000	25,700	95
100	37,500	36,400	32,600	32,600	31,000	31,000	26,800	26,600	25,800	25,800	25,900	25,700	100
105	35,000	35,000	30,800	30,800	29,300	29,300	25,500	25,300	24,400	24,300	24,400	24,400	105
110	32,600	32,600	29,100	29,100	27,800	27,800	24,300	24,100	23,200	23,000	23,000	23,000	110
115	30,300	30,300	27,600	27,600	26,300	26,300	23,100	23,000	22,100	22,000	21,700	21,700	115
120	28,100	28,100	26,100	26,100	25,000	25,000	22,100	21,900	21,000	20,900	20,500	20,500	120
125	26,100	26,100	24,900	24,600	23,700	23,700	21,100	20,700	20,000	19,900	19,400	19,400	125
130	24,300	24,300	24,000	23,600	22,500	22,500	19,900	19,800	19,100	19,100	18,400	18,400	130
135	22,700	22,700	23,100	22,800	21,400	21,400	19,100	19,000	18,300	18,200	17,400	17,400	135
140	21,200	21,200	21,800	21,800	20,300	20,300	18,300	18,200	17,500	17,500	16,400	16,400	140
145	19,400	19,300	20,400	20,400	18,800	18,800	17,400	17,400	16,700	16,700	15,500	15,500	145
150			19,000	19,000	17,500	17,500	16,500	16,500	16,000	16,000	14,700	14,700	150
155			17,800	17,800	16,400	16,400	15,700	15,700	15,400	15,300	13,900	13,900	155
160			14,600	14,600	15,300	15,300	14,900	14,900	14,700	14,700	13,100	13,100	160
165					14,200	14,200	14,100	14,100	14,100	14,100	12,400	12,400	165
170					13,200	13,200	13,100	13,100	13,600	13,600	11,800	11,800	170
175					11,600	11,600	12,100	12,100	12,900	12,900	11,100	11,100	175
180							11,200	11,200	12,000	12,000	10,500	10,500	180
185							10,500	10,500	11,200	11,200	9,900	9,900	185
190							9,600	9,600	10,400	10,400	9,200	9,200	190
195									9,600	9,600	8,400	8,400	195
200									8,900	8,900	7,700	7,700	200
205									6,300	6,300	7,000	7,000	205
210											6,400	6,400	210
215											5,800	5,800	215
220											5,200	5,200	220

Note: Capacities depict multiple boom modes.

This information is not for crane operation. Operator must refer to the in-cab information for crane operation. Rated lifting capacities shown on fully extended outriggers do not exceed 85% of the tipping loads.

Manual Offset Fly Attachment Lift Capacity Charts – Optional

36,000 lb Counterweight - Fully Extended Outriggers - 360° Rotation
 (All Capacities Are Listed In Pounds)

223 ft Main Boom Length									
Radius (ft)	40 ft Manual Offset Fly				67 ft Manual Offset Fly				Radius (ft)
	2°	15°	30°	45°	2°	15°	30°	45°	
40									40
45	14,900								45
50	14,900				10,100				50
55	14,900	14,800			10,100				55
60	14,900	14,800			10,100				60
65	14,900	14,800	14,600		10,100				65
70	14,900	14,800	14,600		10,100	10,100			70
75	14,900	14,800	14,600	14,300	10,100	10,100			75
80	14,900	14,800	14,600	14,300	10,100	10,100			80
85	14,900	14,800	14,600	14,300	10,100	10,100	9,900		85
90	13,900	14,800	14,600	14,300	10,100	10,100	9,900		90
95	12,000	13,300	14,600	14,300	10,100	10,100	9,900		95
100	10,300	11,500	12,800	13,700	10,100	10,100	9,900	9,700	100
105	8,900	10,000	11,100	12,000	9,800	10,100	9,900	9,700	105
110	7,500	8,600	9,600	10,500	8,500	10,100	9,900	9,700	110
115	6,300	7,300	8,300	9,100	7,300	9,000	9,900	9,700	115
120	5,200	6,200	7,100	7,800	6,200	7,800	9,500	9,700	120
125	4,300	5,100	6,000	6,600	5,100	6,700	8,300	9,500	125
130	3,400	4,200	5,000	5,600	4,200	5,700	7,200	8,400	130
135	2,500	3,300	4,100	4,600	3,400	4,800	6,200	7,300	135
140		2,500	3,200	3,700	2,600	3,900	5,200	6,300	140
145			2,400	2,900		3,100	4,400	5,300	145
150				2,100		2,400	3,600	4,500	150
155							2,800	3,700	155
160							2,100	2,900	160
165								2,200	165

This information is not for crane operation. Operator must refer to the in-cab information for crane operation. Rated lifting capacities shown on fully extended outriggers do not exceed 85% of the tipping loads.

156,500 lb Counterweight - Fully Extended Outriggers - 360° Rotation (All Capacities Are Listed In Pounds)									
223 ft Main Boom Length									
Radius (ft)	40 ft Manual Offset Fly				67 ft Manual Offset Fly				Radius (ft)
	2°	15°	30°	45°	2°	15°	30°	45°	
40									40
45	14,900								45
50	14,900				10,100				50
55	14,900	14,800			10,100				55
60	14,900	14,800			10,100				60
65	14,900	14,800	14,600		10,100				65
70	14,900	14,800	14,600		10,100	10,100			70
75	14,900	14,800	14,600	14,300	10,100	10,100			75
80	14,900	14,800	14,600	14,300	10,100	10,100			80
85	14,900	14,800	14,600	14,300	10,100	10,100	9,900		85
90	14,900	14,800	14,600	14,300	10,100	10,100	9,900		90
95	14,900	14,800	14,600	14,300	10,100	10,100	9,900		95
100	14,900	14,800	14,600	14,300	10,100	10,100	9,900	9,700	100
105	14,900	14,800	14,600	14,300	10,100	10,100	9,900	9,700	105
110	14,900	14,800	14,600	14,300	10,100	10,100	9,900	9,700	110
115	14,900	14,800	14,600	14,300	10,100	10,100	9,900	9,700	115
120	14,900	14,800	14,600	14,300	10,100	10,100	9,900	9,700	120
125	14,900	14,800	14,600	14,300	10,100	10,100	9,900	9,500	125
130	14,900	14,800	14,600	14,300	10,100	10,100	9,900	9,400	130
135	14,900	14,800	14,600	14,300	10,100	10,100	9,900	9,300	135
140	14,900	14,800	14,600	14,300	10,100	10,100	9,900	9,200	140
145	14,900	14,800	14,600	14,300	10,100	10,100	9,900	9,100	145
150	14,300	14,600	14,600	14,300	10,100	10,100	9,900	9,000	150
155	13,500	13,800	14,000	14,200	10,100	10,100	9,800	8,900	155
160	12,800	13,100	13,300	13,500	10,100	10,100	9,600	8,800	160
165	12,100	12,400	12,600	12,700	10,100	10,100	9,500	8,700	165
170	11,400	11,700	11,900	12,100	10,100	10,100	9,300	8,600	170
175	10,800	11,100	11,300	11,400	10,100	10,100	9,200	8,500	175
180	10,200	10,500	10,700	10,800	10,100	10,100	9,100	8,500	180
185	9,700	9,900	10,100	10,200	9,600	10,000	9,000	8,400	185
190	9,100	9,400	9,500	9,600	9,100	9,500	8,800	8,300	190
195	8,600	8,800	9,000	9,100	8,500	9,000	8,700	8,300	195
200	8,100	8,300	8,500	8,500	8,100	8,500	8,600	8,200	200
205	7,600	7,800	8,000	8,000	7,600	8,000	8,300	8,200	205
210	7,200	7,400	7,500	7,500	7,200	7,500	7,800	8,000	210
215	6,600	6,900	7,000	7,100	6,700	7,100	7,400	7,500	215
220	6,000	6,300	6,500		6,300	6,700	6,900	7,100	220
225	5,400	5,700	5,800		5,900	6,300	6,500	6,600	225
230	4,900	5,100	5,200		5,600	5,900	6,100	6,200	230
235	4,400	4,600	4,600		5,100	5,500	5,700	5,700	235
240	3,900	4,000	4,100		4,600	5,000	5,300	5,300	240
245	3,400	3,500			4,100	4,500	4,800		245
250					3,600	4,000	4,300		250
255					3,200	3,500	3,700		255
260					2,800	3,100	3,200		260
265					2,400	2,600	2,700		265
270						2,200			270

This information is not for crane operation. Operator must refer to the in-cab information for crane operation. Rated lifting capacities shown on fully extended outriggers do not exceed 85% of the tipping loads.

156,500 lb Counterweight - Fully Extended Outriggers - 360° Rotation (All Capacities Are Listed In Pounds)									
223 ft Main Boom Length									
Radius (ft)	92 ft Manual Offset Fly				117 ft Manual Offset Fly				Radius (ft)
	2°	15°	30°	45°	2°	15°	30°	45°	
60	7,100								60
65	7,100								65
70	7,100				5,300				70
75	7,100	7,000			5,300				75
80	7,100	7,000			5,300				80
85	7,100	7,000			5,300	5,300			85
90	7,100	7,000			5,300	5,300			90
95	7,100	7,000	6,800		5,300	5,300			95
100	7,100	7,000	6,800		5,300	5,300			100
105	7,100	7,000	6,800	6,600	5,300	5,300	5,100		105
110	7,100	7,000	6,800	6,600	5,300	5,300	5,100		110
115	7,100	7,000	6,800	6,600	5,300	5,300	5,100	4,900	115
120	7,100	7,000	6,800	6,600	5,300	5,300	5,100	4,900	120
125	7,100	7,000	6,800	6,600	5,300	5,300	5,100	4,900	125
130	7,100	7,000	6,800	6,600	5,300	5,300	5,100	4,900	130
135	7,100	7,000	6,800	6,600	5,300	5,300	5,100	4,900	135
140	7,100	7,000	6,800	6,600	5,300	5,300	5,100	4,900	140
145	7,100	7,000	6,800	6,600	5,300	5,300	5,100	4,900	145
150	7,100	7,000	6,800	6,600	5,300	5,300	5,100	4,900	150
155	7,100	7,000	6,800	6,600	5,300	5,300	5,100	4,900	155
160	7,100	7,000	6,800	6,600	5,300	5,300	5,100	4,900	160
165	7,100	7,000	6,800	6,600	5,300	5,300	5,100	4,900	165
170	7,100	7,000	6,800	6,600	5,300	5,300	5,100	4,900	170
175	7,100	7,000	6,800	6,600	5,300	5,300	5,100	4,900	175
180	7,100	7,000	6,800	6,600	5,300	5,300	5,100	4,900	180
185	7,100	7,000	6,800	6,600	5,300	5,300	5,100	4,900	185
190	7,100	7,000	6,800	6,600	5,300	5,300	5,100	4,900	190
195	7,100	7,000	6,800	6,600	5,300	5,300	5,100	4,800	195
200	7,100	7,000	6,800	6,600	5,300	5,300	4,900	4,700	200
205	6,900	7,000	6,800	6,600	5,300	5,100	4,700	4,600	205
210	6,500	6,900	6,700	6,500	5,300	4,900	4,600	4,400	210
215	6,100	6,500	6,600	6,300	5,200	4,800	4,500	4,300	215
220	5,700	6,100	6,400	6,200	5,000	4,600	4,300	4,200	220
225	5,300	5,700	6,000	6,100	4,600	4,400	4,200	4,100	225
230	4,900	5,300	5,600	5,700	4,200	4,300	4,100	4,000	230
235	4,600	4,900	5,200	5,300	3,900	4,200	3,900	3,900	235
240	4,200	4,500	4,800	4,900	3,600	3,900	3,800	3,700	240
245	3,900	4,200	4,400	4,500	3,200	3,600	3,700	3,600	245
250	3,500	3,900	4,100	4,200	2,900	3,300	3,600	3,500	250
255	3,100	3,500	3,800	3,800	2,600	3,000	3,200	3,400	255
260	2,600	3,100	3,400	3,400	2,300	2,600	2,900	3,000	260
265	2,200	2,600	2,900	2,900		2,300	2,600	2,700	265
270		2,200	2,500			2,100	2,300	2,400	270

This information is not for crane operation. Operator must refer to the in-cab information for crane operation. Rated lifting capacities shown on fully extended outriggers do not exceed 85% of the tipping loads.

Hydraulic Offset Fly Attachment Lift Capacity Charts – Optional

36,000 lb Counterweight - Fully Extended Outriggers - 360° Rotation
 (All Capacities Are Listed In Pounds)

223 ft Main Boom Length

Radius (ft)	40 ft Hydraulic Offset Fly				67 ft Hydraulic Offset Fly				Radius (ft)
	2°–4°	4°–15°	15°–30°	30°–45°	2°–4°	4°–15°	15°–30°	30°–45°	
40	14,800	14,800							40
45	14,800	14,800			10,000	10,000			45
50	14,800	14,800	14,800		10,000	10,000			50
55	14,800	14,800	14,800		10,000	10,000			55
60	14,800	14,800	14,500	14,500	10,000	10,000			60
65	14,800	14,800	14,500	14,500	10,000	10,000	10,000		65
70	14,800	14,800	14,500	14,200	10,000	10,000	10,000		70
75	14,800	14,800	14,500	14,200	10,000	10,000	10,000		75
80	14,800	14,800	14,500	14,200	10,000	10,000	10,000		80
85	14,800	14,800	14,500	14,200	10,000	10,000	9,900	9,900	85
90	13,900	14,000	14,500	14,200	10,000	10,000	9,900	9,900	90
95	12,000	12,100	13,300	14,200	10,000	10,000	9,900	9,900	95
100	10,300	10,400	11,500	12,800	10,000	10,000	9,900	9,600	100
105	8,900	9,000	10,000	11,100	9,800	10,000	9,900	9,600	105
110	7,500	7,600	8,600	9,600	8,500	8,600	9,900	9,600	110
115	6,300	6,400	7,300	8,300	7,300	7,400	9,000	9,600	115
120	5,200	5,300	6,200	7,100	6,200	6,300	7,800	9,500	120
125	4,300	4,300	5,100	6,000	5,100	5,300	6,700	8,300	125
130	3,400	3,400	4,200	5,000	4,200	4,300	5,700	7,200	130
135	2,500	2,600	3,300	4,100	3,400	3,500	4,800	6,200	135
140			2,500	3,200	2,600	2,700	3,900	5,200	140
145				2,400			3,100	4,400	145
150							2,400	3,600	150
155								2,800	155
160								2,100	160

This information is not for crane operation. Operator must refer to the in-cab information for crane operation. Rated lifting capacities shown on fully extended outriggers do not exceed 85% of the tipping loads.

156,500 lb Counterweight - Fully Extended Outriggers - 360° Rotation (All Capacities Are Listed In Pounds)									
223 ft Main Boom Length									
Radius (ft)	40 ft Hydraulic Offset Fly				67 ft Hydraulic Offset Fly				Radius (ft)
	2°—4°	4°—15°	15°—30°	30°—45°	2°—4°	4°—15°	15°—30°	30°—45°	
40	14,800	14,800							40
45	14,800	14,800			10,000	10,000			45
50	14,800	14,800	14,800		10,000	10,000			50
55	14,800	14,800	14,800		10,000	10,000			55
60	14,800	14,800	14,500	14,500	10,000	10,000			60
65	14,800	14,800	14,500	14,500	10,000	10,000	10,000		65
70	14,800	14,800	14,500	14,200	10,000	10,000	10,000		70
75	14,800	14,800	14,500	14,200	10,000	10,000	10,000		75
80	14,800	14,800	14,500	14,200	10,000	10,000	10,000		80
85	14,800	14,800	14,500	14,200	10,000	10,000	9,900	9,900	85
90	14,800	14,800	14,500	14,200	10,000	10,000	9,900	9,900	90
95	14,800	14,800	14,500	14,200	10,000	10,000	9,900	9,900	95
100	14,800	14,800	14,500	14,200	10,000	10,000	9,900	9,600	100
105	14,800	14,800	14,500	14,200	10,000	10,000	9,900	9,600	105
110	14,800	14,800	14,500	14,200	10,000	10,000	9,900	9,600	110
115	14,800	14,800	14,500	14,200	10,000	10,000	9,900	9,600	115
120	14,800	14,800	14,500	14,200	10,000	10,000	9,900	9,600	120
125	14,800	14,800	14,500	14,200	10,000	10,000	9,900	9,500	125
130	14,800	14,800	14,500	14,200	10,000	10,000	9,900	9,400	130
135	14,800	14,800	14,500	14,200	10,000	10,000	9,900	9,300	135
140	14,800	14,800	14,500	14,200	10,000	10,000	9,900	9,200	140
145	14,800	14,800	14,500	14,200	10,000	10,000	9,900	9,100	145
150	14,300	14,300	14,500	14,200	10,000	10,000	9,900	9,000	150
155	13,500	13,500	13,800	14,000	10,000	10,000	9,800	8,900	155
160	12,800	12,800	13,100	13,300	10,000	10,000	9,600	8,800	160
165	12,100	12,100	12,400	12,600	10,000	10,000	9,500	8,700	165
170	11,400	11,500	11,700	11,900	10,000	10,000	9,300	8,600	170
175	10,800	10,900	11,100	11,300	10,000	10,000	9,200	8,500	175
180	10,200	10,300	10,500	10,700	10,000	10,000	9,100	8,500	180
185	9,700	9,700	9,900	10,100	9,600	9,600	9,000	8,400	185
190	9,100	9,100	9,400	9,500	9,100	9,100	8,800	8,300	190
195	8,600	8,600	8,800	9,000	8,600	8,600	8,700	8,300	195
200	8,100	8,100	8,300	8,500	8,100	8,100	8,500	8,200	200
205	7,600	7,700	7,800	8,000	7,600	7,600	8,000	8,200	205
210	7,200	7,200	7,400	7,500	7,200	7,200	7,500	7,800	210
215	6,600	6,600	6,900	7,000	6,700	6,800	7,100	7,400	215
220	6,000	6,000	6,300	6,500	6,300	6,400	6,700	6,900	220
225	5,400	5,400	5,700	5,800	5,900	6,000	6,300	6,500	225
230	4,900	4,900	5,100	5,100	5,600	5,600	5,900	6,100	230
235	4,400	4,400	4,600	4,500	5,100	5,100	5,500	5,700	235
240	3,900	3,900	4,000	3,900	4,600	4,600	5,000	5,300	240
245	3,400	3,400	3,500		4,100	4,100	4,500	4,800	245
250					3,600	3,700	4,000	4,200	250
255					3,200	3,200	3,500	3,600	255
260					2,800	2,800	3,100	3,000	260
265					2,400	2,400	2,600		265
270							2,200		270

This information is not for crane operation. Operator must refer to the in-cab information for crane operation. Rated lifting capacities shown on fully extended outriggers do not exceed 85% of the tipping loads.

156,500 lb Counterweight - Fully Extended Outriggers - 360° Rotation (All Capacities Are Listed In Pounds)									
223 ft Main Boom Length									
Radius (ft)	92 ft Hydraulic Offset Fly				117 ft Hydraulic Offset Fly				Radius (ft)
	2°–4°	4°–15°	15°–30°	30°–45°	2°–4°	4°–15°	15°–30°	30°–45°	
50	7,000	7,000							50
55	7,000	7,000							55
60	7,000	7,000			5,300	5,300			60
65	7,000	7,000			5,300	5,300			65
70	7,000	7,000	7,000		5,300	5,300			70
75	7,000	7,000	7,000		5,300	5,300			75
80	7,000	7,000	7,000		5,300	5,200	5,200		80
85	7,000	7,000	6,800	6,800	5,300	5,200	5,200		85
90	7,000	7,000	6,800	6,800	5,300	5,200	5,200		90
95	7,000	7,000	6,800	6,800	5,300	5,200	5,100	5,100	95
100	7,000	7,000	6,800	6,800	5,300	5,200	5,100	5,100	100
105	7,000	7,000	6,800	6,800	5,300	5,200	5,100	5,100	105
110	7,000	7,000	6,800	6,800	5,300	5,200	5,100	5,100	110
115	7,000	7,000	6,800	6,800	5,300	5,200	5,100	5,100	115
120	7,000	7,000	6,800	6,800	5,300	5,200	5,100	5,100	120
125	7,000	7,000	6,800	6,800	5,300	5,200	5,100	5,100	125
130	7,000	7,000	6,800	6,800	5,300	5,200	5,100	5,100	130
135	7,000	7,000	6,800	6,800	5,300	5,200	5,100	5,100	135
140	7,000	7,000	6,800	6,800	5,300	5,200	5,100	5,100	140
145	7,000	7,000	6,800	6,800	5,300	5,200	5,100	5,100	145
150	7,000	7,000	6,800	6,800	5,300	5,200	5,100	5,100	150
155	7,000	7,000	6,800	6,800	5,300	5,200	5,100	5,100	155
160	7,000	7,000	6,800	6,800	5,300	5,200	5,100	5,100	160
165	7,000	7,000	6,800	6,800	5,300	5,200	5,100	5,100	165
170	7,000	7,000	6,800	6,800	5,300	5,200	5,100	5,100	170
175	7,000	7,000	6,800	6,800	5,300	5,200	5,100	5,100	175
180	7,000	7,000	6,800	6,800	5,300	5,200	5,100	5,100	180
185	7,000	7,000	6,800	6,800	5,300	5,200	5,100	5,100	185
190	7,000	7,000	6,800	6,800	5,300	5,200	5,100	5,000	190
195	7,000	7,000	6,800	6,800	5,300	5,200	5,100	4,800	195
200	7,000	7,000	6,800	6,700	5,300	5,200	4,900	4,700	200
205	6,900	7,000	6,800	6,600	5,300	5,100	4,700	4,600	205
210	6,500	6,500	6,700	6,500	5,300	4,900	4,600	4,400	210
215	6,100	6,100	6,500	6,300	5,100	4,800	4,500	4,300	215
220	5,700	5,700	6,100	6,200	4,900	4,600	4,300	4,200	220
225	5,300	5,300	5,700	6,000	4,600	4,400	4,200	4,100	225
230	4,900	4,900	5,300	5,600	4,200	4,300	4,100	4,000	230
235	4,600	4,600	4,900	5,200	3,900	3,900	3,900	3,900	235
240	4,200	4,200	4,500	4,800	3,600	3,600	3,800	3,700	240
245	3,900	3,900	4,200	4,500	3,200	3,300	3,600	3,600	245
250	3,500	3,600	3,900	4,100	2,900	2,900	3,300	3,500	250
255	3,100	3,100	3,500	3,800	2,600	2,600	3,000	3,200	255
260	2,600	2,700	3,100	3,400	2,300	2,300	2,600	2,900	260
265	2,200	2,300	2,600	2,900		2,100	2,300	2,600	265
270			2,200	2,400			2,100	2,300	270
275									275
280									280

This information is not for crane operation. Operator must refer to the in-cab information for crane operation. Rated lifting capacities shown on fully extended outriggers do not exceed 85% of the tipping loads.

Metric Main Boom Lift Capacity Charts

0t Counterweight - Fully Extended Outriggers - 360° Rotation (All Capacities Are Listed In Kilograms)

Radius (m)	Boom Length (m)									Radius (m)
	13.3	517.5-17.9	21.7-22.7	26-27.7	30.3-32.1	34.8-36.5	39.3-40.7	44.2-44.8	48.5-49.2	
3.0	148 300	137 400	121 900	102 100						3.0
3.5	135 500	136 650	121 900	102 100						3.5
4.0	123 300	125 300	121 450	102 050						4.0
4.5	109 550	111 650	111 250	96 200	77 300					4.5
5.0	92 450	95 600	94 850	93 750	77 300					5.0
6.0	68 450	71 750	72 650	72 450	71 450	64 750	46 650			6.0
7.0	48 550	52 500	54 300	54 900	54 700	51 200	46 650			7.0
8.0	35 200	39 200	40 850	41 400	41 200	40 450	39 200	38 350	30 000	8.0
9.0	26 200	29 900	31 950	32 900	33 150	32 800	32 050	30 950	30 000	9.0
10.0	20 100	23 700	25 600	26 500	26 700	27 200	26 900	26 200	25 150	10.0
12.0		15 950	17 700	18 500	19 050	19 150	19 200	18 250	17 800	12.0
14.0		11 200	13 000	13 750	14 250	14 350	14 400	13 500	13 950	14.0
16.0			9 750	10 550	11 000	11 100	11 150	10 300	10 750	16.0
18.0			7 300	8 200	8 700	8 800	8 800	8 000	8 450	18.0
20.0			2 100	6 350	6 950	7 050	7 150	6 300	6 750	20.0
22.0				4 900	5 500	5 650	5 700	4 850	5 300	22.0
24.0				2 050	4 300	4 450	4 550	3 750	4 150	24.0
26.0					3 350	3 500	3 600	2 800	3 250	26.0
28.0					1 350	2 700	2 800	2 050	2 450	28.0
30.0						2 000	2 100	1 400	1 800	30.0
32.0						1,450	1,550		1,250	32.0
34.0							1,050			34.0

Note: Capacities depict multiple boom modes.

This information is not for crane operation. Operator must refer to the in-cab information for crane operation. Rated lifting capacities shown on fully extended outriggers do not exceed 75% of the tipping loads.

**16.3t Counterweight - Fully Extended Outriggers - 360° Rotation
(All Capacities Are Listed In Kilograms)**

Radius (m)	Boom Length (m)													Radius (m)	
	13.3	17.5-17.9	21.7-22.7	26-27.7	30.3-32.1	34.8-36.5	39.3-41.4	44.2-44.8	48.5-49.8	53.9-54.1	58.1-58.8	63-63.8	68.0		
3.0	151 600	137 400	121 900	102 100										3.0	
3.5	138 650	137 400	121 900	102 100										3.5	
4.0	127 500	128 700	121 450	102 050										4.0	
4.5	117 900	119 200	114 650	96 200	77 300									4.5	
5.0	108 900	110 950	109 450	95 950	77 300									5.0	
6.0	89 950	92 250	92 100	91 550	77 300	64 750	46 650							6.0	
7.0	70 250	73 500	74 450	74 250	73 350	64 750	46 650							7.0	
8.0	55 950	58 950	60 050	60 100	59 450	58 300	54 100	38 350	31 850					8.0	
9.0	44 000	47 450	48 850	49 300	49 150	48 450	46 650	38 350	31 850	25 000	16 050			9.0	
10.0	35 700	39 100	40 400	40 800	40 650	40 000	39 100	38 350	31 850	25 000	20 650	15 550		10.0	
12.0		28 100	29 500	29 900	30 750	30 500	29 900	29 000	29 400	25 000	20 650	16 650	13 650	12.0	
14.0		21 050	22 800	23 500	23 600	23 450	23 750	23 250	22 400	21 700	20 650	16 650	13 650	14.0	
16.0			17 950	18 650	18 850	19 200	18 950	18 400	17 800	17 550	16 950	16 450	13 650	16.0	
18.0			14 500	15 250	15 700	15 700	15 750	15 050	15 450	14 250	14 650	14 100	13 600	18.0	
20.0			8 650	12 600	13 100	13 200	13 250	12 450	12 850	11 700	12 100	11 550	11 050	20.0	
22.0				10 600	11 100	11 150	11 200	10 450	10 800	9 700	10 100	9 550	9 050	22.0	
24.0				7 250	9 450	9 550	9 600	8 850	9 200	8 050	8 500	7 850	7 500	24.0	
26.0					8 100	8 200	8 250	7 550	7 900	6 750	7 200	6 600	6 100	26.0	
28.0					5 750	7 050	7 150	6 400	6 800	5 600	6 050	5 450	4 950	28.0	
30.0						6 050	6 150	5 400	5 850	4 650	5 050	4 500	4 000	30.0	
32.0							5 200	5 300	4 550	5 000	3 800	4 200	3 650	3 150	32.0
34.0								4 550	3 800	4 200	3 050	3 500	2 900	2 450	34.0
36.0									3 900	3 150	3 550	2 450	2 300	1 800	36.0
38.0										2 550	3 000	1 850	2 300	1 750	38.0
40.0											2 050	2 450	1 800	1 250	40.0
42.0												2 000	1 300		42.0
44.0													1 600		44.0

Note: Capacities depict multiple boom modes.

This information is not for crane operation. Operator must refer to the in-cab information for crane operation. Rated lifting capacities shown on fully extended outriggers do not exceed 75% of the tipping loads.

Metric Main Boom Lift Capacity Charts – Optional

36.3t Counterweight - Fully Extended Outriggers - 360° Rotation (All Capacities Are Listed In Kilograms)															
Radius (m)	Boom Length (m)												Radius (m)		
	13.3	17.5-17.9	21.7-22.7	26-27.7	30.3-32.1	34.8-36.5	39.3-41.4	44.2-44.8	48.5-49.8	53.9-54.1	58.1-58.8	63-63.8		68.0	
3.0	154 450	137 400	121 900	102 100										3.0	
3.5	142 050	137 400	121 900	102 100										3.5	
4.0	131 000	131 800	121 450	102 050										4.0	
4.5	121 200	122 450	114 650	96 200	77 300									4.5	
5.0	112 600	114 000	112 750	95 950	77 300									5.0	
6.0	98 300	99 900	98 800	95 950	77 300	64 750	46 650							6.0	
7.0	85 650	87 900	87 750	87 250	77 300	64 750	46 650							7.0	
8.0	73 950	76 300	76 200	75 850	74 400	64 750	54 100	38 350	31 850					8.0	
9.0	62 900	66 000	65 950	65 400	66 350	64 750	51 900	38 350	31 850	25 000	16 050			9.0	
10.0	52 850	55 700	56 600	56 650	56 100	55 100	48 200	38 350	31 850	25 000	20 650	15 550		10.0	
12.0		41 200	42 550	42 900	42 750	42 200	41 250	36 300	31 850	25 000	20 650	16 650	13 650	12.0	
14.0		31 900	33 250	33 650	33 500	32 950	32 100	32 750	31 850	25 000	20 650	16 650	13 650	14.0	
16.0			26 900	27 350	27 200	27 300	27 350	26 500	25 850	25 000	20 650	16 650	13 650	16.0	
18.0			22 300	22 750	22 900	23 350	22 800	22 050	22 400	21 800	20 550	16 650	13 650	18.0	
20.0			16 250	19 250	20 000	19 850	19 300	19 650	18 900	18 300	18 350	16 650	13 650	20.0	
22.0				17 050	17 250	17 100	17 300	16 900	16 200	16 150	16 000	15 550	13 650	22.0	
24.0				13 450	15 050	14 950	15 250	14 800	14 100	14 100	14 450	13 950	13 500	24.0	
26.0					13 250	13 400	13 450	13 000	12 300	12 250	12 650	12 100	11 650	26.0	
28.0					10 950	12 050	11 900	11 450	10 900	10 750	11 100	10 550	10 150	28.0	
30.0						10 750	10 600	10 150	10 150	9 450	9 800	9 250	8 800	30.0	
32.0							9 650	9 600	9 000	9 350	8 250	8 650	8 100	7 700	32.0
34.0								8 700	8 000	8 400	7 350	7 750	7 200	6 700	34.0
36.0								7 900	7 150	7 550	6 450	6 850	6 300	5 800	36.0
38.0								4 550	6 300	6 750	5 650	6 050	5 500	5 000	38.0
40.0									5 600	6 050	4 900	5 350	4 800	4 300	40.0
42.0									3 900	5 400	4 250	4 700	4 150	3 700	42.0
44.0										4 800	3 700	4 100	3 600	3 150	44.0
46.0										3 200	3 150	3 600	3 050	2 600	46.0
48.0											2 700	3 100	2 600	2 150	48.0
50.0											2 300	2 700	2 150	1 700	50.0
52.0													2 300	1 300	52.0
54.0													1 950	950	54.0
56.0													1 100		56.0

Note: Capacities depict multiple boom modes.

This information is not for crane operation. Operator must refer to the in-cab information for crane operation. Rated lifting capacities shown on fully extended outriggers do not exceed 75% of the tipping loads.

**46.3t Counterweight - Fully Extended Outriggers - 360° Rotation
(All Capacities Are Listed In Kilograms)**

Radius (m)	Boom Length (m)													Radius (m)
	13.3	17.5-17.9	21.7-22.7	26-27.7	30.3-32.1	34.8-36.5	39.3-41.4	44.2-44.8	48.5-49.8	53.9-54.1	58.1-58.8	63-63.8	68.0	
3.0	155 650	137 400	121 900	102 100										3.0
3.5	143 200	137 400	121 900	102 100										3.5
4.0	132 450	133 100	121 450	102 050										4.0
4.5	122 800	123 700	114 650	96 200	77 300									4.5
5.0	114 150	115 150	114 250	95 950	77 300									5.0
6.0	99 700	101 250	100 150	95 950	77 300	64 750	46 650							6.0
7.0	88 200	89 850	88 800	89 300	77 300	64 750	46 650							7.0
8.0	78 150	80 400	80 300	79 900	74 400	64 750	54 100	38 350	31 850					8.0
9.0	68 500	70 850	70 800	70 500	69 650	64 750	51 900	38 350	31 850	25 000	16 050			9.0
10.0	60 700	63 050	63 050	62 800	63 500	62 700	48 200	38 350	31 850	25 000	20 650	15 550		10.0
12.0		47 400	48 300	48 300	47 800	48 150	46 650	36 300	31 850	25 000	20 650	16 650	13 650	12.0
14.0		37 250	38 500	38 700	38 850	38 300	37 400	33 350	31 850	25 000	20 650	16 650	13 650	14.0
16.0			31 350	31 800	31 650	31 200	30 350	30 800	28 800	25 000	20 650	16 650	13 650	16.0
18.0			26 100	26 550	26 500	26 000	26 600	25 800	25 150	23 800	20 550	16 650	13 650	18.0
20.0			19 650	22 650	22 600	23 200	22 700	21 950	21 500	21 700	18 850	16 650	13 650	20.0
22.0				19 500	19 550	20 100	19 600	18 900	19 200	18 650	17 500	16 650	13 650	22.0
24.0				16 150	17 750	17 600	17 150	17 450	16 750	16 150	16 150	15 700	13 650	24.0
26.0					15 750	15 600	15 150	15 450	14 800	14 350	14 250	14 600	13 650	26.0
28.0					13 250	13 850	14 000	13 750	13 100	13 050	12 850	12 900	12 450	28.0
30.0						12 400	12 700	12 300	11 650	11 600	11 950	11 450	11 000	30.0
32.0							11 150	11 450	11 000	10 400	10 350	10 700	9 800	32.0
34.0								10 350	9 950	9 300	9 300	9 600	8 650	34.0
36.0								9 400	8 950	8 250	8 250	8 650	7 650	36.0
38.0								6 400	8 100	7 700	7 450	7 750	6 900	38.0
40.0									7 350	7 200	6 650	7 050	6 100	40.0
42.0									5 550	6 750	5 900	6 300	5 350	42.0
44.0										6 350	5 250	5 650	4 700	44.0
46.0										4 700	4 700	5 100	4 150	46.0
48.0											4 150	4 550	3 600	48.0
50.0											3 700	4 050	3 100	50.0
52.0												3 600	2 650	52.0
54.0												3 200	2 250	54.0
56.0												1 950	1 850	56.0
58.0												1 950	1 500	58.0
60.0													1 200	60.0

Note: Capacities depict multiple boom modes.

This information is not for crane operation. Operator must refer to the in-cab information for crane operation. Rated lifting capacities shown on fully extended outriggers do not exceed 75% of the tipping loads.

71.0t Counterweight - Fully Extended Outriggers - 360° Rotation (All Capacities Are Listed In Kilograms)															
Radius (m)	Boom Length (m)												Radius (m)		
	13.3	17.5-17.9	21.7-22.7	26-27.7	30.3-32.1	34.8-36.5	39.3-41.4	44.2-44.8	48.5-49.8	53.9-54.1	58.1-58.8	63-63.8		68.0	
2.5	250 000*													2.5	
3.0	230 000*	137 400	121 900	102 100										3.0	
3.5	146 000	137 400	121 900	102 100										3.5	
4.0	135 100	135 550	121 450	102 050										4.0	
4.5	125 600	126 300	114 650	96 200	77 300									4.5	
5.0	117 200	118 050	114 650	95 950	77 300									5.0	
6.0	103 050	104 100	103 300	95 950	77 300	64 750	46 650							6.0	
7.0	91 250	92 750	91 800	92 250	77 300	64 750	46 650							7.0	
8.0	81 600	83 350	82 300	82 800	74 400	64 750	54 100	38 350	31 850					8.0	
9.0	73 550	75 400	74 650	75 000	72 300	64 750	51 900	38 350	31 850	25 000	16 050			9.0	
10.0	66 800	68 700	68 650	68 350	67 650	64 750	48 200	38 350	31 850	25 000	20 650	15 550		10.0	
12.0		58 000	57 950	57 700	57 050	57 650	46 650	36 300	31 850	25 000	20 650	16 650	13 650	12.0	
14.0		48 750	48 750	48 500	49 400	48 600	46 150	33 350	31 850	25 000	20 650	16 650	13 650	14.0	
16.0			41 650	40 650	41 350	40 550	41 250	30 800	28 800	25 000	20 650	16 650	13 650	16.0	
18.0			34 950	35 100	34 700	35 450	34 650	28 600	26 150	23 800	20 550	16 650	13 650	18.0	
20.0			28 050	30 050	29 750	30 450	29 700	26 650	23 800	22 300	18 850	16 650	13 650	20.0	
22.0				26 850	26 900	26 500	25 700	25 000	21 800	20 650	17 500	16 650	13 650	22.0	
24.0				22 900	23 700	23 300	22 600	23 150	20 050	19 000	16 300	16 050	13 650	24.0	
26.0					21 050	20 650	20 800	20 550	18 550	17 600	15 250	14 850	13 650	26.0	
28.0					18 900	18 450	19 000	18 350	17 150	16 350	14 300	13 700	13 650	28.0	
30.0						17 000	17 150	16 450	15 900	15 200	13 400	12 850	12 750	30.0	
32.0							15 250	15 550	14 900	14 900	14 150	12 650	12 100	11 850	32.0
34.0								14 150	13 500	13 850	13 250	11 900	11 400	11 000	34.0
36.0								12 950	12 300	12 600	12 100	11 250	10 750	10 250	36.0
38.0								9 300	11 700	11 500	11 000	10 550	10 150	9 600	38.0
40.0									11 200	10 550	10 050	9 900	9 600	8 950	40.0
42.0									7 900	9 700	9 100	9 150	9 050	8 350	42.0
44.0										8 850	8 250	8 300	8 600	7 800	44.0
46.0										8 150	7 600	7 650	7 950	7 350	46.0
48.0											7 000	7 000	7 350	6 850	48.0
50.0											6 600	6 600	6 700	6 300	50.0
52.0												6 250	6 150	5 700	52.0
54.0													5 900	5 150	54.0
56.0													4 750	4 700	56.0
58.0														4 250	58.0
60.0														3 800	60.0
62.0														3 450	62.0

Note: Capacities depict multiple boom modes.
 * Over rear intermediate outriggers additional equipment required.

This information is not for crane operation. Operator must refer to the in-cab information for crane operation. Rated lifting capacities shown on fully extended outriggers do not exceed 75% of the tipping loads.

Metric Manual & Hydraulic Offset Fly Attachment Lift Capacity Charts – Optional

16.3t Counterweight - Fully Extended Outriggers - 360° Rotation (All Capacities Are Listed In Kilograms)

Main Boom + 3.7m Offset Fly (Manual Offsets 2°, 15°, 30°, 45° & Hydraulic Offsets 2° - 45°)

Boom Length (m)															
Radius (m)	13.3		17.5 – 17.9		21.6 – 22.7		26.0 – 27.6		30.3 – 32.1		34.8 – 36.4		39.2 – 41.4		Radius (m)
	2°–4°	4°–45°	2°–4°	4°–45°	2°–4°	4°–45°	2°–4°	4°–45°	2°–4°	4°–45°	2°–4°	4°–45°	2°–4°	4°–45°	
3.0	31 600	31 600	31 550	31 550	31 500	31 500	31 450	31 450							3.0
3.5	31 600	31 600	31 550	31 550	31 500	31 500	31 450	31 450							3.5
4.0	31 600	31 600	31 550	31 550	31 500	31 500	31 450	31 450							4.0
4.5	31 600	31 600	31 550	31 550	31 500	31 500	31 450	31 450	31 450	31 450	31 400	31 400	31 350	31 350	4.5
5.0	31 600	31 600	31 550	31 550	31 500	31 500	31 450	31 450	31 450	31 450	31 400	31 400	31 350	31 350	5.0
6.0	31 600	31 600	31 550	31 550	31 500	31 500	31 450	31 450	31 450	31 450	31 400	31 400	31 350	31 350	6.0
7.0	31 600	31 600	31 550	31 550	31 500	31 500	31 450	31 450	31 450	31 400	31 400	31 400	31 350	31 350	7.0
8.0	31 600	31 600	31 550	31 550	31 500	31 500	31 450	31 450	31 450	31 400	31 400	31 400	31 350	31 350	8.0
9.0	31 600	31 600	31 550	31 550	31 500	31 500	31 450	31 450	31 450	31 400	31 400	31 400	31 350	31 350	9.0
10.0	31 600	31 250	31 550	31 550	31 500	31 500	31 450	31 450	31 450	31 400	31 400	31 400	31 350	31 350	10.0
12.0	27 500	27 500	29 050	29 050	29 750	29 750	29 900	29 900	29 600	29 600	30 100	28 950	29 500	29 500	12.0
14.0			22 100	22 100	22 750	22 750	22 900	22 900	23 550	23 550	23 200	23 200	22 550	22 550	14.0
16.0			17 350	17 350	18 250	18 250	18 650	18 650	18 650	18 650	18 850	18 400	18 600	18 600	16.0
18.0			14 100	14 100	14 900	14 900	15 250	15 250	15 500	15 250	15 500	15 500	15 500	15 450	18.0
20.0					12 350	12 350	12 650	12 650	12 950	12 950	12 900	12 900	12 850	12 850	20.0
22.0					10 400	10 400	10 650	10 650	10 900	10 900	10 900	10 900	10 850	10 850	22.0
24.0							9 100	9 100	9 300	9 300	9 250	9 250	9 200	9 200	24.0
26.0							7 800	7 800	8 000	8 000	7 950	7 950	7 900	7 900	26.0
28.0							2 500	2 500	6 900	6 900	6 800	6 800	6 800	6 800	28.0
30.0									5 900	5 900	5 850	5 850	5 800	5 800	30.0
32.0									2 800	2 800	5 000	5 000	4 950	4 950	32.0
34.0											4 300	4 300	4 250	4 250	34.0
36.0											2 100	2 100	3 600	3 600	36.0
38.0													3 050	3 050	38.0
40.0													2 350	2 350	40.0
42.0															42.0
44.0															44.0

Note: Capacities depict multiple boom modes.

This information is not for crane operation. Operator must refer to the in-cab information for crane operation. Rated lifting capacities shown on fully extended outriggers do not exceed 85% of the tipping loads.

16.3t Counterweight - Fully Extended Outriggers - 360° Rotation (All Capacities Are Listed In Kilograms)													
Main Boom + 3.7m Offset Fly (Manual Offsets 2°, 15°, 30°, 45° & Hydraulic Offsets 2° - 45°)													
Boom Length (m)													
Radius (m)	44.2 – 44.8		48.5 – 49.7		53.8 – 54.1		58.0 – 58.8		63.0 – 63.8		68		Radius (m)
	2°–4°	4°–45°	2°–4°	4°–45°	2°–4°	4°–45°	2°–4°	4°–45°	2°–4°	4°–45°	2°–4°	4°–45°	
3.0													3.0
3.5													3.5
4.0													4.0
4.5													4.5
5.0													5.0
6.0	31 300	31 250	15 350	15 300									6.0
7.0	31 300	31 250	15 350	15 300									7.0
8.0	31 300	31 250	26 400	25 850	21 600	21 200	16 650	16 650					8.0
9.0	31 300	31 250	26 400	25 850	21 600	21 200	16 650	16 550	14 450	14 450			9.0
10.0	31 300	31 250	26 400	25 850	21 600	21 200	16 650	16 450	14 450	14 250	11 800	11 700	10.0
12.0	28 550	28 550	26 400	25 850	21 600	21 200	16 650	16 450	14 450	14 250	11 800	11 650	12.0
14.0	22 850	22 850	21 950	21 950	21 200	21 200	16 650	16 450	14 450	14 250	11 800	11 650	14.0
16.0	18 000	18 000	17 150	17 150	17 050	16 950	16 400	16 400	14 450	14 250	11 800	11 650	16.0
18.0	14 650	14 650	15 000	15 000	13 800	13 800	13 950	13 750	13 450	13 250	11 800	11 650	18.0
20.0	12 050	12 050	12 400	12 400	11 250	11 250	11 550	11 550	11 000	11 000	10 500	10 500	20.0
22.0	10 050	10 050	10 350	10 350	9 200	9 200	9 550	9 550	8 950	8 950	8 400	8 400	22.0
24.0	8 400	8 400	8 750	8 750	7 650	7 650	7 900	7 900	7 400	7 400	6 850	6 850	24.0
26.0	7 100	7 100	7 450	7 450	6 250	6 250	6 600	6 600	6 000	6 000	5 500	5 500	26.0
28.0	5 950	5 950	6 300	6 300	5 100	5 100	5 450	5 450	4 850	4 850	4 350	4 350	28.0
30.0	4 950	4 950	5 300	5 300	4 100	4 100	4 500	4 500	3 900	3 900	3 400	3 400	30.0
32.0	4 150	4 150	4 450	4 450	3 300	3 300	3 650	3 650	3 050	3 050	2 550	2 550	32.0
34.0	3 400	3 400	3 750	3 750	2 550	2 550	2 900	2 900	2 350	2 350	1 850	1 850	34.0
36.0	2 800	2 800	3 100	3 100	1 950	1 950	2 300	2 300	1 700	1 700	1 200	1 200	36.0
38.0	2 250	2 250	2 550	2 550	1 400	1 400	1 750	1 750	1 150	1 150			38.0
40.0	1 750	1 750	2 050	2 050			1 250	1 250					40.0
42.0	1 300	1 300	1 600	1 600									42.0
44.0			1 200	1 200									44.0

Note: Capacities depict multiple boom modes.

This information is not for crane operation. Operator must refer to the in-cab information for crane operation. Rated lifting capacities shown on fully extended outriggers do not exceed 85% of the tipping loads.

71.0t Counterweight - Fully Extended Outriggers - 360° Rotation (All Capacities Are Listed In Kilograms)															
Main Boom + 3.7m Offset Fly (Manual Offsets 2°, 15°, 30°, 45° & Hydraulic Offsets 2° - 45°)															
Boom Length (m)															
Radius (m)	13.3		17.5 – 17.9		21.6 – 22.7		26.0 – 27.6		30.3 – 32.1		34.8 – 36.4		39.2 – 41.4		Radius (m)
	2°–4°	4°–45°	2°–4°	4°–45°	2°–4°	4°–45°	2°–4°	4°–45°	2°–4°	4°–45°	2°–4°	4°–45°	2°–4°	4°–45°	
3.0	31 600	31 600	31 550	31 550	31 500	31 500	31 450	31 450							3.0
3.5	31 600	31 600	31 550	31 550	31 500	31 500	31 450	31 450							3.5
4.0	31 600	31 600	31 550	31 550	31 500	31 500	31 450	31 450							4.0
4.5	31 600	31 600	31 550	31 550	31 500	31 500	31 450	31 450	31 450	31 450	31 400	31 400	31 350	31 350	4.5
5.0	31 600	31 600	31 550	31 550	31 500	31 500	31 450	31 450	31 450	31 450	31 400	31 400	31 350	31 350	5.0
6.0	31 600	31 600	31 550	31 550	31 500	31 500	31 450	31 450	31 450	31 450	31 400	31 400	31 350	31 350	6.0
7.0	31 600	31 600	31 550	31 550	31 500	31 500	31 450	31 450	31 450	31 400	31 400	31 400	31 350	31 350	7.0
8.0	31 600	31 600	31 550	31 550	31 500	31 500	31 450	31 450	31 450	31 400	31 400	31 400	31 350	31 350	8.0
9.0	31 600	31 600	31 550	31 550	31 500	31 500	31 450	31 450	31 450	31 400	31 400	31 400	31 350	31 350	9.0
10.0	31 600	31 250	31 550	31 550	31 500	31 500	31 450	31 450	31 450	31 400	31 400	31 400	31 350	31 350	10.0
12.0	31 600	27 950	31 550	31 550	31 500	31 500	31 450	31 450	31 400	31 400	31 400	31 400	31 350	31 350	12.0
14.0			31 550	30 300	31 500	31 500	31 450	31 450	31 400	31 400	31 400	31 400	31 350	31 350	14.0
16.0			31 550	27 750	31 500	31 500	31 450	31 450	31 400	31 400	31 400	31 400	31 350	31 350	16.0
18.0			29 250	26 200	31 500	29 750	31 450	31 450	31 400	31 400	31 400	31 400	31 350	31 350	18.0
20.0					30 400	27 750	30 200	30 200	29 650	29 650	30 200	30 200	29 400	29 400	20.0
22.0					26 500	26 200	26 250	26 250	25 700	25 700	26 250	26 250	25 450	25 450	22.0
24.0							23 100	23 100	23 400	23 250	23 150	23 150	22 350	22 350	24.0
26.0							21 100	20 950	21 050	21 050	20 500	20 500	19 750	19 750	26.0
28.0							16 150	16 150	18 850	18 850	18 300	18 300	17 550	17 550	28.0
30.0									17 050	17 050	16 450	16 450	15 950	15 700	30.0
32.0									14 450	14 450	14 950	14 950	15 050	14 700	32.0
34.0											13 550	13 550	13 950	13 950	34.0
36.0											12 400	12 400	12 750	12 750	36.0
38.0													11 650	11 650	38.0
40.0													10 750	10 750	40.0
42.0													5 850	5 850	42.0
44.0															44.0
46.0															46.0
48.0															48.0
50.0															50.0
52.0															52.0
54.0															54.0
56.0															56.0
58.0															58.0
60.0															60.0
62.0															62.0
64.0															64.0
66.0															66.0

Note: Capacities depict multiple boom modes.

This information is not for crane operation. Operator must refer to the in-cab information for crane operation. Rated lifting capacities shown on fully extended outriggers do not exceed 85% of the tipping loads.

71.0t Counterweight - Fully Extended Outriggers - 360° Rotation (All Capacities Are Listed In Kilograms)													
Main Boom + 3.7m Offset Fly (Manual Offsets 2°, 15°, 30°, 45° & Hydraulic Offsets 2° - 45°)													
Boom Length (m)													
Radius (m)	44.2 – 44.8		48.5 – 49.7		53.8 – 54.1		58.0 – 58.8		63.0 – 63.8		68		Radius (m)
	2°–4°	4°–45°	2°–4°	4°–45°	2°–4°	4°–45°	2°–4°	4°–45°	2°–4°	4°–45°	2°–4°	4°–45°	
3.0													3.0
3.5													3.5
4.0													4.0
4.5													4.5
5.0													5.0
6.0	31 300	31 250	15 350	15 300									6.0
7.0	31 300	31 250	15 350	15 300									7.0
8.0	31 300	31 250	26 400	25 850	21 600	21 200	16 650	16 650					8.0
9.0	31 300	31 250	26 400	25 850	21 600	21 200	16 650	16 550	14 450	14 450			9.0
10.0	31 300	31 250	26 400	25 850	21 600	21 200	16 650	16 450	14 450	14 250	11 800	11 700	10.0
12.0	31 300	31 250	26 400	25 850	21 600	21 200	16 650	16 450	14 450	14 250	11 800	11 650	12.0
14.0	30 550	28 700	26 400	25 850	21 600	21 200	16 650	16 450	14 450	14 250	11 800	11 650	14.0
16.0	27 950	26 400	26 400	25 850	21 600	21 200	16 650	16 450	14 450	14 250	11 800	11 650	16.0
18.0	25 700	24 400	25 100	24 950	21 600	21 050	16 650	16 450	14 450	14 250	11 800	11 650	18.0
20.0	23 800	22 700	22 800	22 700	20 400	19 600	16 650	16 450	14 450	14 250	11 800	11 650	20.0
22.0	22 150	21 200	20 800	20 750	18 950	18 250	16 450	16 250	14 450	14 250	11 800	11 650	22.0
24.0	20 700	19 850	19 050	19 050	17 750	17 150	15 250	15 050	14 450	14 250	11 800	11 650	24.0
26.0	19 400	18 700	17 650	17 600	16 700	16 150	14 200	14 050	14 050	14 050	11 800	11 650	26.0
28.0	18 000	17 650	16 300	16 250	15 450	15 250	13 200	13 100	12 950	12 950	11 800	11 650	28.0
30.0	16 100	16 100	15 050	15 050	14 350	14 350	12 350	12 250	11 950	11 950	11 800	11 650	30.0
32.0	14 600	14 600	13 950	13 950	13 300	13 300	11 550	11 450	11 050	11 050	11 050	11 050	32.0
34.0	13 200	13 200	12 650	12 650	12 400	12 400	10 850	10 750	10 350	10 300	10 250	10 250	34.0
36.0	12 000	12 000	11 900	11 650	11 550	11 550	10 200	10 100	9 700	9 650	9 500	9 500	36.0
38.0	10 950	10 950	11 150	11 100	10 600	10 600	9 600	9 550	9 100	9 050	8 850	8 850	38.0
40.0	10 000	10 000	10 200	10 200	9 600	9 600	8 950	8 900	8 600	8 550	8 200	8 200	40.0
42.0	9 300	9 200	9 350	9 350	8 700	8 700	8 450	8 400	8 100	8 050	7 650	7 650	42.0
44.0	8 850	8 800	8 500	8 500	7 900	7 900	7 850	7 850	7 650	7 600	7 100	7 100	44.0
46.0			7 850	7 800	7 200	7 200	7 200	7 200	7 200	7 200	6 600	6 600	46.0
48.0			6 250	6 250	6 550	6 550	6 500	6 500	6 850	6 800	6 150	6 150	48.0
50.0					5 950	5 950	5 900	5 900	6 250	6 250	5 700	5 700	50.0
52.0					5 500	5 500	5 450	5 450	5 650	5 650	5 200	5 200	52.0
54.0					5 150	5 150	5 100	5 100	5 150	5 150	4 650	4 650	54.0
56.0							4 800	4 800	4 650	4 650	4 200	4 200	56.0
58.0									4 200	4 200	3 750	3 750	58.0
60.0									3 800	3 800	3 350	3 350	60.0
62.0									2 650	2 650	2 950	2 950	62.0
64.0											2 600	2 600	64.0
66.0											2 300	2 300	66.0

Note: Capacities depict multiple boom modes.

This information is not for crane operation. Operator must refer to the in-cab information for crane operation. Rated lifting capacities shown on fully extended outriggers do not exceed 85% of the tipping loads.

Metric Manual Offset Fly Attachment Lift Capacity Charts – Optional

16.3t Counterweight - Fully Extended Outriggers - 360° Rotation
(All Capacities Are Listed In Kilograms)

68m Main Boom Length

Radius (m)	12.2m Manual Offset Fly				20.4m Manual Offset Fly				Radius (m)
	2°	15°	30°	45°	2°	15°	30°	45°	
14	6 750								14
16	6 750				4 550				16
18	6 750	6 700			4 550				18
20	6 750	6 700	6 600		4 550				20
22	6 750	6 700	6 600	6 450	4 550	4 550			22
24	6 750	6 700	6 600	6 450	4 550	4 550			24
26	6 050	6 700	6 600	6 450	4 550	4 550	4 450		26
28	4 900	5 500	6 150	6 450	4 550	4 550	4 450		28
30	3 900	4 500	5 050	5 500	4 350	4 550	4 450	4 350	30
32	3 050	3 600	4 100	4 500	3 500	4 400	4 450	4 350	32
34	2 350	2 800	3 300	3 650	2 750	3 600	4 450	4 350	34
36	1 700	2 150	2 550	2 900	2 100	2 850	3 650	4 300	36
38	1 150	1 550	1 950	2 250	1 550	2 250	3 000	3 550	38
40		1 000	1 350	1 650	1 000	1 700	2 350	2 900	40
42				1 100		1 200	1 800	2 300	42
44							1 300	1 750	44
46								1 250	46

This information is not for crane operation. Operator must refer to the in-cab information for crane operation. Rated lifting capacities shown on fully extended outriggers do not exceed 75% of the tipping loads.

71.0t Counterweight - Fully Extended Outriggers - 360° Rotation (All Capacities Are Listed In Kilograms)									
68m Main Boom Length									
Radius (m)	12.2m Manual Offset Fly				20.4m Manual Offset Fly				Radius (m)
	2°	15°	30°	45°	2°	15°	30°	45°	
14	6 750								14
16	6 750				4 550				16
18	6 750	6 700			4 550				18
20	6 750	6 700	6 600		4 550				20
22	6 750	6 700	6 600	6 450	4 550	4 550			22
24	6 750	6 700	6 600	6 450	4 550	4 550			24
26	6 750	6 700	6 600	6 450	4 550	4 550	4 450		26
28	6 750	6 700	6 600	6 450	4 550	4 550	4 450		28
30	6 750	6 700	6 600	6 450	4 550	4 550	4 450	4 350	30
32	6 750	6 700	6 600	6 450	4 550	4 550	4 450	4 350	32
34	6 750	6 700	6 600	6 450	4 550	4 550	4 450	4 350	34
36	6 750	6 700	6 600	6 450	4 550	4 550	4 450	4 350	36
38	6 750	6 700	6 600	6 450	4 550	4 550	4 450	4 350	38
40	6 750	6 700	6 600	6 450	4 550	4 550	4 450	4 250	40
42	6 750	6 700	6 600	6 450	4 550	4 550	4 450	4 200	42
44	6 750	6 700	6 600	6 450	4 550	4 550	4 450	4 100	44
46	6 400	6 550	6 600	6 450	4 550	4 550	4 450	4 050	46
48	5 950	6 100	6 200	6 300	4 550	4 550	4 400	4 000	48
50	5 550	5 650	5 800	5 850	4 550	4 550	4 300	3 950	50
52	5 150	5 250	5 400	5 450	4 550	4 550	4 200	3 900	52
54	4 800	4 900	5 000	5 050	4 550	4 550	4 150	3 850	54
56	4 450	4 550	4 650	4 700	4 400	4 550	4 100	3 800	56
58	4 100	4 200	4 300	4 350	4 100	4 300	4 000	3 800	58
60	3 700	3 850	4 000	4 000	3 800	3 950	3 950	3 750	60
62	3 300	3 450	3 550	3 600	3 500	3 700	3 850	3 700	62
64	2 950	3 050	3 200	3 200	3 250	3 400	3 550	3 650	64
66	2 600	2 700	2 800		2 900	3 150	3 300	3 350	66
68	2 300	2 400	2 450		2 600	2 800	3 000	3 050	68
70	2 000	2 100	2 150		2 300	2 500	2 700	2 750	70
72	1 700	1 800	1 800		2 000	2 200	2 350	2 400	72
74	1 450	1 500			1 750	1 900	2 050	2 050	74
76					1 500	1 650	1 750		76
78					1 250	1 400	1 450		78
80					1 050	1 150	1 200		80

This information is not for crane operation. Operator must refer to the in-cab information for crane operation. Rated lifting capacities shown on fully extended outriggers do not exceed 75% of the tipping loads.

**71.0t Counterweight - Fully Extended Outriggers - 360° Rotation
(All Capacities Are Listed In Kilograms)**

68m Main Boom Length									
Radius (m)	28m Manual Offset Fly				35.7m Manual Offset Fly				Radius (m)
	2°	15°	30°	45°	2°	15°	30°	45°	
20	3 200								20
22	3 200	3 150			2 400				22
24	3 200	3 150			2 400				24
26	3 200	3 150			2 400	2 400			26
28	3 200	3 150			2 400	2 400			28
30	3 200	3 150	3 050		2 400	2 400			30
32	3 200	3 150	3 050	2 950	2 400	2 400	2 300		32
34	3 200	3 150	3 050	2 950	2 400	2 400	2 300		34
36	3 200	3 150	3 050	2 950	2 400	2 400	2 300	2 200	36
38	3 200	3 150	3 050	2 950	2 400	2 400	2 300	2 200	38
40	3 200	3 150	3 050	2 950	2 400	2 400	2 300	2 200	40
42	3 200	3 150	3 050	2 950	2 400	2 400	2 300	2 200	42
44	3 200	3 150	3 050	2 950	2 400	2 400	2 300	2 200	44
46	3 200	3 150	3 050	2 950	2 400	2 400	2 300	2 200	46
48	3 200	3 150	3 050	2 950	2 400	2 400	2,300	2 200	48
50	3 200	3 150	3 050	2 950	2 400	2 400	2 300	2 200	50
52	3 200	3 150	3 050	2 950	2 400	2 400	2 300	2 200	52
54	3 200	3 150	3 050	2 950	2 400	2 400	2 300	2 200	54
56	3 200	3 150	3 050	2 950	2 400	2 400	2 300	2 200	56
58	3 200	3 150	3 050	2 950	2 400	2 400	2 300	2 200	58
60	3 200	3 150	3 050	2 950	2 400	2 400	2 250	2 150	60
62	3 200	3 150	3 050	2 950	2 400	2 350	2 150	2 100	62
64	2 950	3 150	3 050	2 950	2 400	2 250	2 100	2 000	64
66	2 700	2 850	2 950	2 850	2 300	2 150	2 000	1 950	66
68	2 450	2 650	2 800	2 800	2 150	2 050	1 900	1 850	68
70	2 250	2 400	2 550	2 600	1 950	1 950	1 850	1 800	70
72	1 950	2 200	2 300	2 350	1 750	1 850	1 750	1 750	72
74	1 700	1 900	2 100	2 150	1 550	1 700	1 700	1 650	74
76	1 450	1 650	1 800	1 850	1 350	1 500	1 650	1 600	76
78	1 200	1 400	1 550	1 550	1 150	1 300	1 450	1 500	78
80	1 000	1 150	1 250	1 300		1 100	1 250	1 300	80
82			1 000				1 050	1 100	82

This information is not for crane operation. Operator must refer to the in-cab information for crane operation. Rated lifting capacities shown on fully extended outriggers do not exceed 75% of the tipping loads.

Metric Hydraulic Offset Fly Attachment Lift Capacity Charts – Optional

16.3t Counterweight - Fully Extended Outriggers - 360° Rotation
(All Capacities Are Listed In Kilograms)

68m Main Boom Length

Radius (m)	12.2m Hydraulic Offset Fly				20.4m Hydraulic Offset Fly				Radius (m)
	2°–4°	4°–15°	15°–30°	30°–45°	2°–4°	4°–15°	15°–30°	30°–45°	
12.0	6 700	6 700							12.0
14.0	6 700	6 700			4 550	4 550			14.0
16.0	6 700	6 700	6 700		4 550	4 550			16.0
18.0	6 700	6 700	6 700		4 550	4 550			18.0
20.0	6 700	6 700	6 600	6 600	4 550	4 550	4 550		20.0
22.0	6 700	6 700	6 600	6 450	4 550	4 550	4 550		22.0
24.0	6 700	6 700	6 600	6 450	4 550	4 550	4 550		24.0
26.0	6 050	6 100	6 600	6 450	4 550	4 550	4 450	4 450	26.0
28.0	4 900	4 950	5 500	6 150	4 550	4 550	4 450	4 450	28.0
30.0	3 900	3 950	4 500	5 050	4 350	4 450	4 450	4 350	30.0
32.0	3 050	3 100	3 600	4 100	3 500	3 600	4 400	4 350	32.0
34.0	2 350	2 350	2 800	3 300	2 750	2 800	3 600	4 350	34.0
36.0	1 700	1 750	2 150	2 550	2 100	2 150	2 850	3 650	36.0
38.0	1 150	1 150	1 550	1 950	1 550	1 600	2 250	3 000	38.0
40.0			1 000	1 350	1 000	1 050	1 700	2 350	40.0
42.0							1 200	1 800	42.0
44.0								1 300	44.0

This information is not for crane operation. Operator must refer to the in-cab information for crane operation. Rated lifting capacities shown on fully extended outriggers do not exceed 75% of the tipping loads.

**71.0t Counterweight - Fully Extended Outriggers - 360° Rotation
(All Capacities Are Listed In Kilograms)**

68m Main Boom Length

Radius (m)	12.2m Hydraulic Offset Fly				20.4m Hydraulic Offset Fly				Radius (m)
	2°–4°	4°–15°	15°–30°	30°–45°	2° - 15°	15° - 30°	30° - 45°	30° - 45°	
14.0	6 750								14.0
16.0	6 750				4 550				16.0
18.0	6 750	6 700			4 550				18.0
20.0	6 750	6 700	6 600		4 550				20.0
22.0	6 750	6 700	6 600	6 450	4 550	4 550			22.0
24.0	6 750	6 700	6 600	6 450	4 550	4 550			24.0
26.0	6 750	6 700	6 600	6 450	4 550	4 550	4 450		26.0
28.0	6 750	6 700	6 600	6 450	4 550	4 550	4 450		28.0
30.0	6 750	6 700	6 600	6 450	4 550	4 550	4 450	4 350	30.0
32.0	6 750	6 700	6 600	6 450	4 550	4 550	4 450	4 350	32.0
34.0	6 750	6 700	6 600	6 450	4 550	4 550	4 450	4 350	34.0
36.0	6 750	6 700	6 600	6 450	4 550	4 550	4 450	4 350	36.0
38.0	6 750	6 700	6 600	6 450	4 550	4 550	4 450	4 350	38.0
40.0	6 750	6 700	6 600	6 450	4 550	4 550	4 450	4 250	40.0
42.0	6 750	6 700	6 600	6 450	4 550	4 550	4 450	4 200	42.0
44.0	6 750	6 700	6 600	6 450	4 550	4 550	4 450	4 100	44.0
46.0	6 400	6 550	6 600	6 450	4 550	4 550	4 450	4 050	46.0
48.0	5 950	6 100	6 200	6 300	4 550	4 550	4 400	4 000	48.0
50.0	5 550	5 650	5 800	5 850	4 550	4 550	4 300	3 950	50.0
52.0	5 150	5 250	5 400	5 450	4 550	4 550	4 200	3 900	52.0
54.0	4 800	4 900	5 000	5 050	4 550	4 550	4 150	3 850	54.0
56.0	4 450	4 550	4 650	4 700	4 400	4 550	4 100	3 800	56.0
58.0	4 100	4 200	4 300	4 350	4 100	4 300	4 000	3 800	58.0
60.0	3 700	3 850	4 000	4 000	3 800	3 950	3 950	3 750	60.0
62.0	3 300	3 450	3 550	3 600	3 500	3 700	3 850	3 700	62.0
64.0	2 950	3 050	3 200	3 200	3 250	3 400	3 550	3 650	64.0
66.0	2 600	2 700	2 800		2 900	3 150	3 300	3 350	66.0
68.0	2 300	2 400	2 450		2 600	2 800	3 000	3 050	68.0
70.0	2 000	2 100	2 150		2 300	2 500	2 700	2 750	70.0
72.0	1 700	1 800	1 800		2 000	2 200	2 350	2 400	72.0
74.0	1 450	1 500			1 750	1 900	2 050	2 050	74.0
76.0					1 500	1 650	1 750		76.0
78.0					1 250	1 400	1 450		78.0
80.0					1 050	1 150	1 200		80.0

This information is not for crane operation. Operator must refer to the in-cab information for crane operation. Rated lifting capacities shown on fully extended outriggers do not exceed 75% of the tipping loads.

71.0t Counterweight - Fully Extended Outriggers - 360° Rotation (All Capacities Are Listed In Kilograms)									
68m Main Boom Length									
Radius (m)	28m Hydraulic Offset Fly				35.7m Hydraulic Offset Fly				Radius (m)
	2° - 15°	15° - 30°	30° - 45°	30° - 45°	2° - 15°	15° - 30°	30° - 45°	30° - 45°	
16.0	3 150	3 150							16.0
18.0	3 150	3 150							18.0
20.0	3 150	3 150			2 400	2 400			20.0
22.0	3 150	3 150	3 150		2 400	2 400			22.0
24.0	3 150	3 150	3 150		2 400	2 350	2 350		24.0
26.0	3 150	3 150	3 050	3 050	2 400	2 350	2 350		26.0
28.0	3 150	3 150	3 050	3 050	2 400	2 350	2 350		28.0
30.0	3 150	3 150	3 050	3 050	2 400	2 350	2 300	2 300	30.0
32.0	3 150	3 150	3 050	3 050	2 400	2 350	2 300	2 300	32.0
34.0	3 150	3 150	3 050	3 050	2 400	2 350	2 300	2 300	34.0
36.0	3 150	3 150	3 050	3 050	2 400	2 350	2 300	2 300	36.0
38.0	3 150	3 150	3 050	3 050	2 400	2 350	2 300	2 300	38.0
40.0	3 150	3 150	3 050	3 050	2 400	2 350	2 300	2 300	40.0
42.0	3 150	3 150	3 050	3 050	2 400	2 350	2 300	2 300	42.0
44.0	3 150	3 150	3 050	3 050	2 400	2 350	2 300	2 300	44.0
46.0	3 150	3 150	3 050	3 050	2 400	2 350	2 300	2 300	46.0
48.0	3 150	3 150	3 050	3 050	2 400	2 350	2 300	2 300	48.0
50.0	3 150	3 150	3 050	3 050	2 400	2 350	2 300	2 300	50.0
52.0	3 150	3 150	3 050	3 050	2 400	2 350	2 300	2 300	52.0
54.0	3 150	3 150	3 050	3 050	2 400	2 350	2 300	2 300	54.0
56.0	3 150	3 150	3 050	3 050	2 400	2 350	2 300	2 300	56.0
58.0	3 150	3 150	3 050	3 050	2 400	2 350	2 300	2 250	58.0
60.0	3 150	3 150	3 050	3 050	2 400	2 350	2 250	2 150	60.0
62.0	3 150	3 150	3 050	3 000	2 400	2 350	2 150	2 100	62.0
64.0	2 950	2 950	3 050	2 950	2 400	2 250	2 100	2 000	64.0
66.0	2 700	2 700	2 850	2 850	2 300	2 150	2 000	1 950	66.0
68.0	2 450	2 450	2 650	2 800	2 150	2 050	1 900	1 850	68.0
70.0	2 250	2 250	2 400	2 550	1 950	1 950	1 850	1 800	70.0
72.0	1 950	2 000	2 200	2 300	1 750	1 750	1 750	1 750	72.0
74.0	1 700	1 700	1 900	2 100	1 550	1 550	1 700	1 650	74.0
76.0	1 450	1 450	1 650	1 800	1 350	1 350	1 500	1 600	76.0
78.0	1 200	1 200	1 400	1 550	1 150	1 150	1 300	1 450	78.0
80.0	1 000	1 000	1 150	1 250			1 100	1 250	80.0
82.0				1 000				1 050	82.0

This information is not for crane operation. Operator must refer to the in-cab information for crane operation. Rated lifting capacities shown on fully extended outriggers do not exceed 75% of the tipping loads.

This Page Intentionally Blank

Link-Belt Cranes Lexington, Kentucky www.linkbelt.com

®Link-Belt is a registered trademark. Copyright 2019. We are constantly improving our products and therefore reserve the right to change designs and specifications.