

# Technical Data

## Specifications & Capacities

# TCC 450

Telescopic Crawler Crane  
45 Ton (40.8 metric ton)

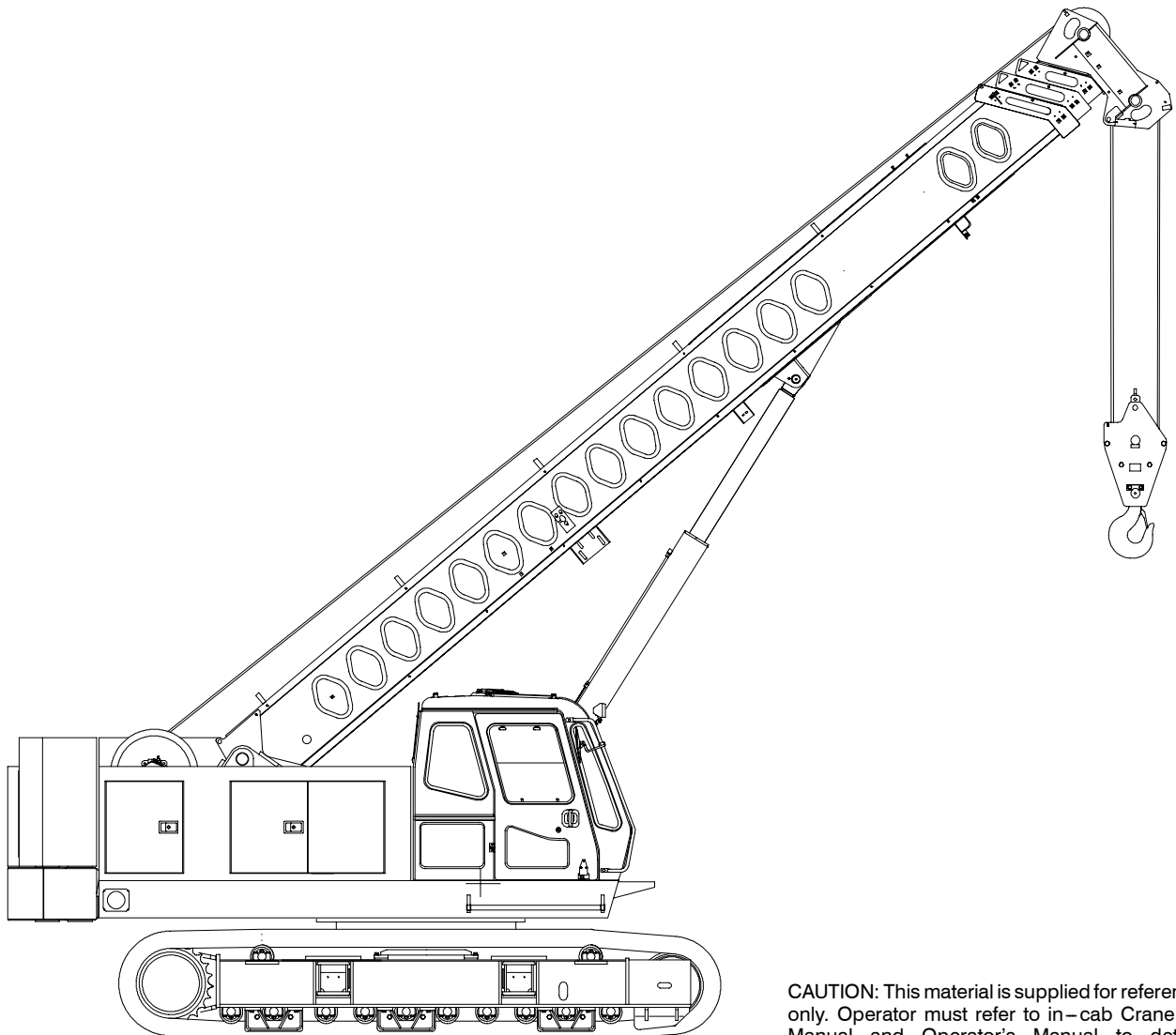

**CAUTION:** This material is supplied for reference use only. Operator must refer to in-cab Crane Rating Manual and Operator's Manual to determine allowable crane lifting capacities and assembly and operating procedures.



# Table Of Contents

<b>Upper Structure</b> .....	<b>1</b>
Frame .....	1
Engine .....	1
Hydraulic System .....	1
Load Hoist Drum .....	1
Optional Auxiliary Hoist Drum .....	1
Swing System .....	1
Counterweight .....	1
Operator's Cab .....	2
Rated Capacity Limiter System .....	2
Machinery Cab .....	2
Catwalks .....	2
<b>Lower Structure</b> .....	<b>2</b>
Carbody .....	2
Side Frames .....	2
Travel and Steering .....	2
<b>Boom and Attachments</b> .....	<b>3</b>
Design .....	3
Boom .....	3
Boom Head .....	3
Boom Elevation .....	3
Optional Auxiliary Lifting Sheave .....	3
Optional Fly .....	3
<b>Dimensions</b> .....	<b>4</b>
Base Crane .....	4
Fly .....	6
Auxiliary Lifting Sheave .....	6
Counterweights .....	7
Hook Balls .....	8
Hook Blocks .....	8
<b>Working Weights</b> .....	<b>9</b>
<b>Transport Drawing</b> .....	<b>9</b>
<b>Load Hoist Performance</b> .....	<b>10</b>
<b>Working Areas</b> .....	<b>11</b>
<b>Boom Extend Modes</b> .....	<b>12</b>
<b>Attachments</b> .....	<b>13</b>
<b>Main Boom Working Range Diagrams</b> .....	<b>14</b>
<b>Main Boom Load Charts</b> .....	<b>16</b>
<b>Main Boom + Fly Load Charts</b> .....	<b>18</b>



# Upper Structure

## Frame

All welded and precision machined surfaces.

### Turntable Bearing

- Inner race with internal swing gear is bolted to lower frame
- Outer race bolted to upper frame

## Engine

### Engine

Full pressure lubrication, oil filter, air cleaner, hour meter, throttle, and electric control shutdown.

### Isuzu AH-4HK1X

Number of cylinders	4
Bore and stroke	4.53 in x 4.92 in (115 x 125mm)
Piston displacement	317 in <sup>3</sup> (5.22L)
Engine rpm at full load speed	2,100 rpm
Hi-idle rpm	2,100 rpm
Gross engine hp	197 hp (147kw)
Peak torque	506 ft lb (688joule) @ 1,500 rpm
Electrical system	24 volt
Fuel tank capacity	80 gal (300L)
Batteries	2-12 volt
Approximate fuel consumption	gal/hr (L/hr)
100% hp	10.27 (38.88)
75% hp	8.12 (30.74)
50% hp	5.97 (22.60)
25% hp	2.98 (11.28)

### Fuel Tank

Equipped with fuel sight level gauge and flame arrester.

## Hydraulic System

### Hydraulic Pumps

The pump arrangement is designed to provide hydraulically powered functions allowing positive, precise control with independent or simultaneous operation of all crane functions.

- Two variable displacement pumps operating at 4,264 psi (300kg/cm<sup>2</sup>) and 57 gal/min (216L/min) powers load hoist drums, boom hoist cylinder, and travel.
- One fixed displacement gear type pump operating at 3,974 psi (280kg/cm<sup>2</sup>) and 35.7 gal/min (135L/min) powers the swing motor.
- One fixed displacement gear type pump operating at 711 psi (50kg/cm<sup>2</sup>) and 8.5 gal/min (32.4L/min) powers the controls.

### Pump Control “Fine Inching” Mode

Special pump setting, selectable from the operator’s cab, that allows very slow movements of load hoist drums, boom hoist drum, and travel for precision work.

### Hydraulic Reservoir

119 gal (450L), equipped with sight level gauge. Diffusers built in for deaeration.

### Filtration

Twelve micron, full flow, line filter in the control circuit. All oil is filtered prior to entering the reservoir.

### Counterbalance Valves

All hoist motors are equipped with counterbalance valves to provide positive load lowering and prevent accidental load drop if the hydraulic pressure is suddenly lost.

## Load Hoist Drum

Each drum contains a pilot controlled, bi-directional, axial piston motor and a planetary gear reduction unit to provide positive control under all load conditions.

- Power up/down
- Automatic multiple wet-disc type brake (spring applied, hydraulically released)
- Drum pawl controlled manually
- Electronic drum rotation indicators
- 16.54 in (42.01cm) root diameter
- 27.56 in (70.00cm) flange diameter
- 14.51 in (36.86cm) width
- Parallel grooved lagging for 18mm wire rope.

The automatic brake mode meets all OSHA requirements for personnel handling.

## Optional Auxiliary Hoist Drum

Each drum contains a pilot controlled, bi-directional, axial piston motor and a planetary gear reduction unit to provide positive control under all load conditions.

- Power up/down
- Automatic multiple wet-disc type brake (spring applied, hydraulically released)
- Electronic drum rotation indicators
- 15.8 in (40.13cm) root diameter
- 27.56 in (70.00cm) flange diameter
- 14.50 in (36.83cm) width
- Parallel grooved lagging for 5/8” wire rope.

## Swing System

Pilot controlled bi-directional axial piston motors and planetary gear reduction units to provide positive control under all load conditions.

- Spring applied, hydraulically released, 360° multiple wet-disc type brake
- Free swing mode when lever is in neutral position
- Two position positive house lock
- Audio/Visual swing alarm
- Maximum swing speed is 3.7 rpm

## Counterweight

Consists of a four piece design.

- One “A” counterweight, 10,803 lb (4 900kg) base slab
- Two “B” counterweights, 6,173 lb (2 800kg) each
- One “C” counterweight, 2,380 lb (1 080kg)
- One counterweight cover, 286 lb (130kg)

## Operator's Cab

Fully enclosed modular steel compartment is independently mounted and padded to protect against vibration and noise.

- All tinted/tempered safety glass
- Sliding entry door and side window
- Door and window locks
- Hot water heater
- Air conditioner
- Sun visor
- Cloth seat
- Circulating fan
- Windshield wipers and washer
- Dry chemical fire extinguisher
- Engine instrumentation panel (tachometer, voltmeter, engine oil pressure, engine water temperature, fuel level, hydraulic oil temperature, hour meter, and service monitor system)
- Mechanical drum rotation indicators for front and rear hoist drums
- Six way adjustable seat
- Hand and foot throttle
- Fully adjustable single axis controls
- Swing lever with swing brake and horn located on handle
- Bubble type level
- Ergonomic gauge layout
- Controls shut off lever
- Right hand control stand is adjustable by electric motor for operator comfort.
- AM/FM Radio

## Rated Capacity Limiter System

The rated capacity limiter system is a wireless load cell system. This system provides the operator with useful geometrical data, to include:

- Main Boom Length
- Main Boom Angle
- Operating Mode
- Load Radius
- Boom Tip Height
- Audible Alarm
- Pre-Warning Light
- Overload Light
- Load On Hook
- Function kick-outs including over load
- Operator settable stops (ramped stops)
- Wireless Anti-Two Block Indicator
- Wireless load cell

## Machinery Cab

Hinged doors (two on right side, three on left side) for machinery access. Equipped with rooftop access ladder and skid resistant finish on roof.

## Catwalks

Standard on right and left sides. Catwalks fold up and pin for reduced travel width.

# Lower Structure

## Carbody

### Lower Frame

All welded box construction frame with precision machined surfaces for turntable bearing and rotating joint.

## Side Frames

### Side Frames

All welded, precision machined, steel frames can be hydraulically extended and retracted by a hydraulic cylinder mounted in the lower frame.

- 10 ft 10 in (4.11m) extended gauge
- 8 ft 4 in (2.54m) retracted gauge
- 18 ft (5.48m) overall length

- 32 in (0.81m) wide track shoes
- Sealed (oil filled) idler and drive planetaries
- Compact travel drives
- Hydraulic self adjusting tracks

### Track Rollers

- Ten sealed (oil filled) track rollers per side frame
- Heat treated, mounted on anti-friction bearings

### Tracks

Heat treated, self-cleaning, tractor type with triple grouser shoes and heat treated track pins with dirt seals. 56 track shoes per side.

### Take Up Idlers

Cast steel, heat treated, self-cleaning, mounted on sealed tapered roller bearings

## Travel and Steering

### Travel and Steering

Each side frame contains a pilot controlled, bi-directional, axial piston motor and a planetary gear reduction unit to provide positive control under all load conditions.

- 2-speed travel
- Individual control provides smooth, precise maneuverability including full counter-rotation.
- Spring applied, hydraulically released multiple wet-disc type brake controlled automatically
- Maximum travel speed is 1.2 mph (1.9km/h).
- Designed to 40% gradeability

# Boom and Attachments

## Design

Four section, box type construction of high tensile steel consisting of one base section and three telescoping sections. The vertical side plates have diamond shaped steel impressions for superior strength to weight ratio. The first telescoping section extends independently by means of one double-acting, single stage hydraulic cylinder with integrated holding valves. The second and third telescoping sections extend proportionally by means of one double-acting, single stage cylinder with integrated holding valves and cables.

## Boom

- 33–105 ft (10.05–32.00m) four section full power boom
- Two mode boom extension: *A-max* mode provides superior capacities by extending the first telescoping section to 57 ft (17.37m). Standard mode synchronizes all the telescoping sections proportionally to 105 ft (32.00m). Controlled from the operator's cab
- Mechanical boom angle indicator
- Maximum tip height for *A-max* mode is 64 ft 11 in (19.79m) and standard mode is 111 ft (33.83m).
- Telescope speed 33 ft – 105 ft (10.21–32.00m) in 70 seconds.

## Boom Head

- Four 16.5 in (41.91cm) root diameter nylon sheaves to handle up to eight parts of line
- Easily removable wire rope guards
- Rope dead end lugs on each side of the boom head
- Boom head is designed for quick-reeve of the hook block

## Boom Elevation

- One double acting hydraulic cylinder with integral holding valve
- Boom elevation:  $-3^{\circ}$  to  $78^{\circ}$
- Boom elevation speed: 0 to  $78^{\circ}$  in 40 seconds

## Optional Auxiliary Lifting Sheave

- Single 16.5 in (41.91m) root diameter nylon sheave
- Easily removable wire rope guards
- Does not affect erection of the fly or use of the main head sheaves

## Optional Fly

- 20 ft (6.10m) one piece fly
- Stowable
- Offsettable to  $2^{\circ}$ ,  $20^{\circ}$ , and  $40^{\circ}$
- Maximum tip height is 128 ft (39.0m)

# Dimensions

## Base Crane

General Dimensions	English	Metric
Basic Boom	33-105 ft	10.05-32.00m
Minimum Load Radius	8.2 ft	2.50m
Maximum Boom Angle	78°	78°
Track Shoe Width	32 in	0.81m

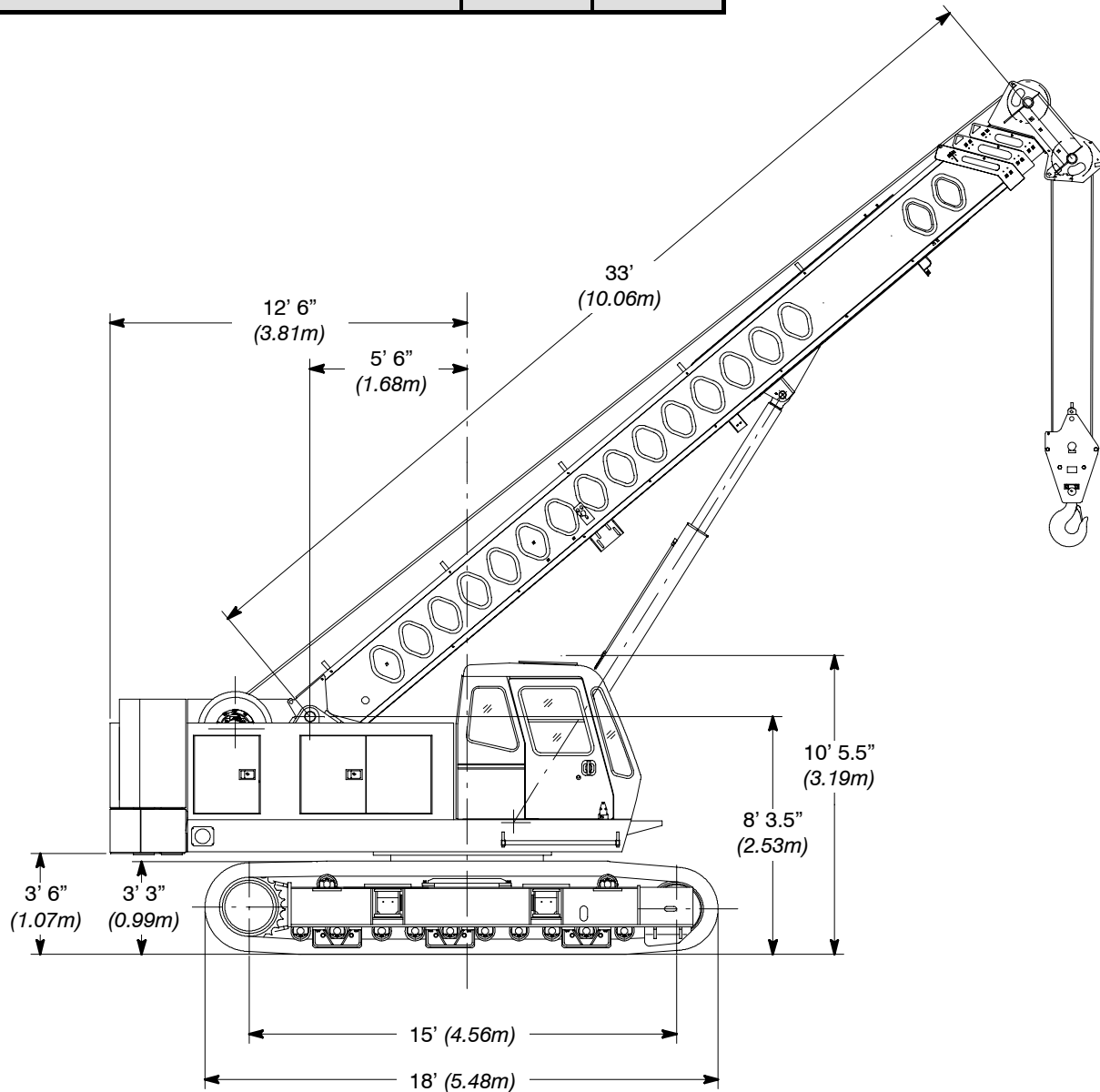

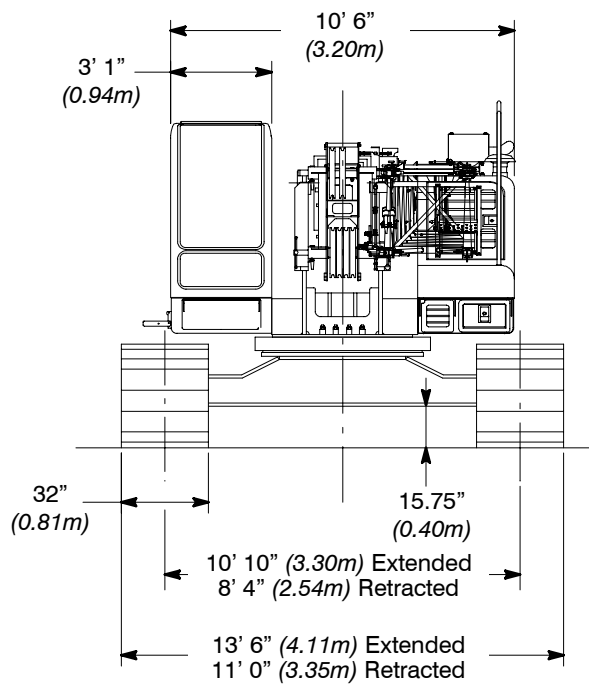
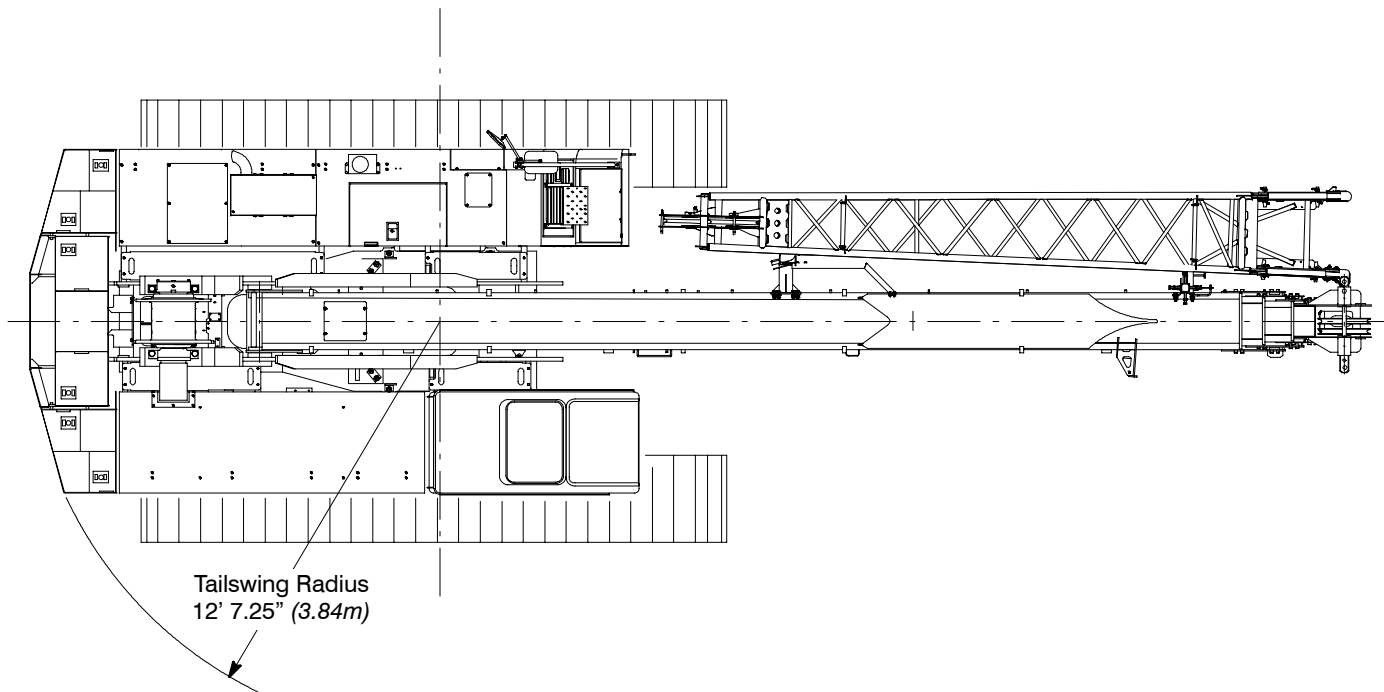

# Auxiliary Lifting Sheave

## Auxiliary Lifting Sheave ①

Length	34.88 in	(0.89m)
Width	16.31 in	(0.41m)
Height	19 in	(0.48m)
Weight	84 lb	(38kg)

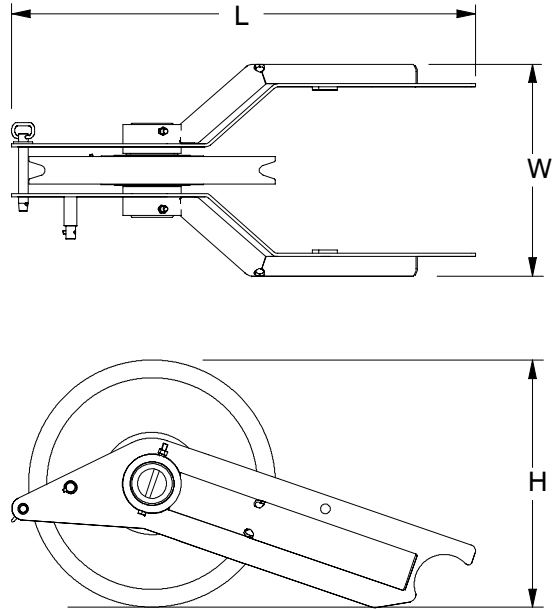

# Fly

## 20 ft (6.10m) Offset Fly ①

Length	21 ft 1 in	(6.43m)
Width	36.40 in	(0.92m)
Height	36.8 in	(0.93m)
Weight	1,049 lb	(476kg)

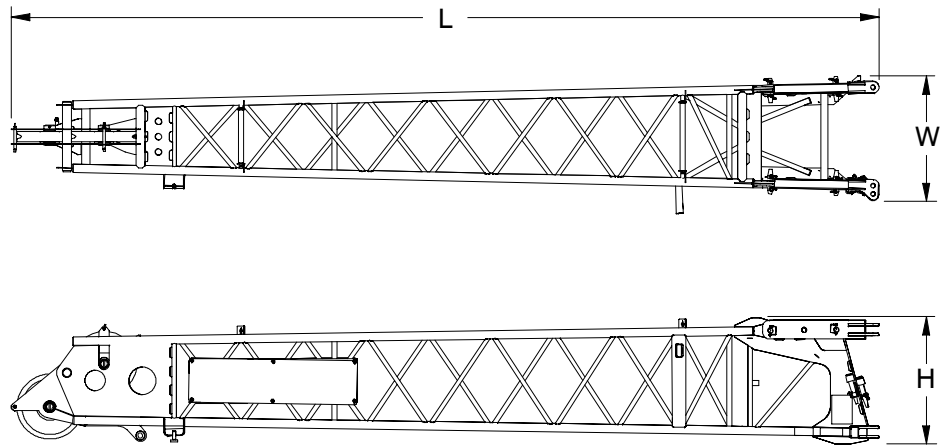

Number inside black circle “①” = # of components

\* – Optional equipment

# Counterweights

## “A” Counterweight ①

Length	32.7 in	(0.83m)
Width	10 ft 6 in	(3.20m)
Height	25.0 in	(0.64m)
Weight	10,803 lb	(4 900kg)

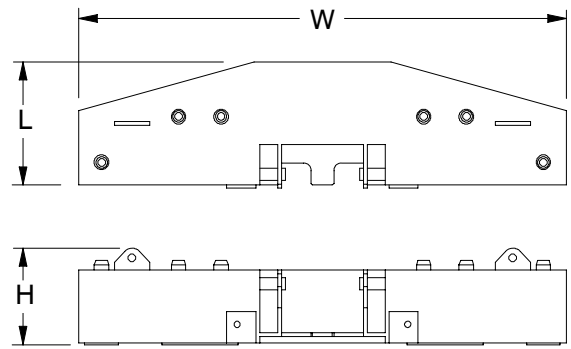

## “B” Counterweight ②

Length	27.8 in	(0.71m)
Width	30.7 in	(0.78m)
Height	50.6 in	(1.29m)
Weight	6,173 lb	(2 800kg)

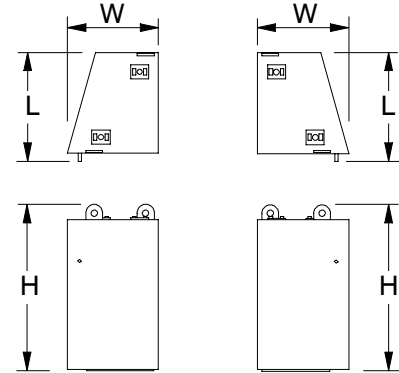

## “C” Counterweight ①

Length	19.7 in	(0.50m)
Width	62.2 in	(1.58m)
Height	21.2 in	(0.54m)
Weight	2,380 lb	(1 080kg)

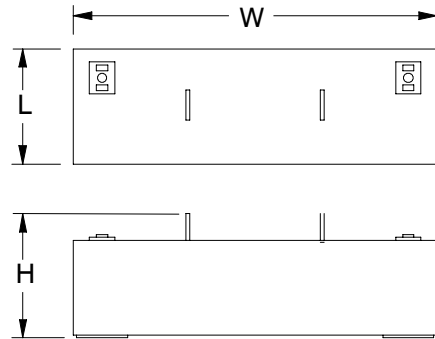

## Counterweight Cover ①

Length	7.9 in	(0.20m)
Width	63 in	(1.60m)
Height	35.4 in	(0.90m)
Weight	286 lb	(130kg)

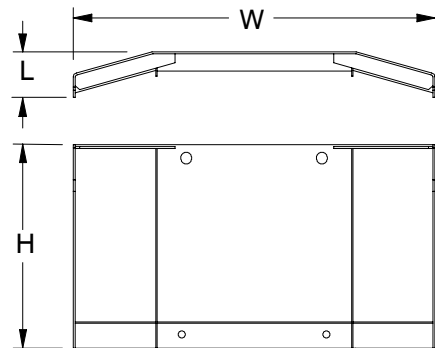

Number inside black circle “①” = # of components  
 \* – Optional equipment

# Hook Balls

## 8.5 Ton (7.7mt) Swivel Hook Ball\* ①

Width	14.5 in	(0.37m)
Height	33.8 in	(0.86m)
Weight	360 lb	(163kg)

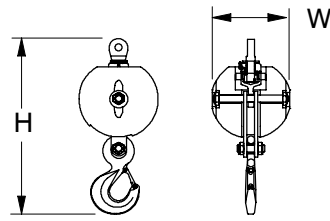

## 8.5 Ton (7.7mt) Non-Swivel Hook Ball\* ①

Width	16.5 in	(0.42m)
Height	35.00 in	(0.89m)
Weight	360 lb	(163kg)

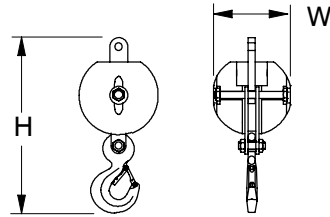

# Hook Blocks

## 30 Ton (27.2mt)

### 3-Sheave Hook Block\* ①

Width1	14.13 in	(0.36m)
Width2	17.88 in	(0.45m)
Height	40.88 in	(1.04m)
Weight	671 lb	(304kg)

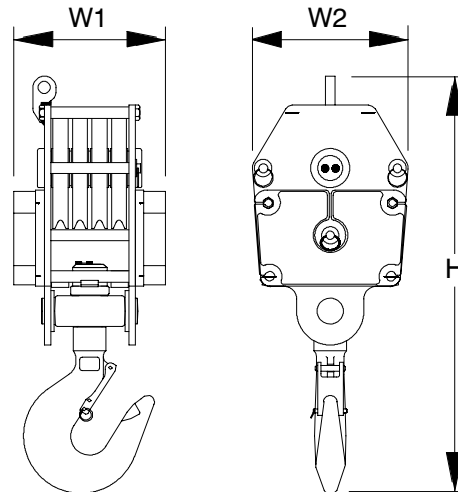

## 40 Ton (36.3mt)

### 4-Sheave Hook Block\* ①

Width1	15.62 in	(0.39m)
Width2	18 in	(0.46m)
Height	43.12 in	(1.10m)
Weight	720 lb	(327kg)

## 45 Ton (40.8mt)

### 4-Sheave Hook Block\* ①

Width1	14.62 in	(0.37m)
Width2	20.12 in	(0.51m)
Height	45.37 in	(1.16m)
Weight	756 lb	(343kg)

Number inside black circle "①" = # of components

\* - Optional equipment

# Working Weights

Option	Description	AB ctwt	
		Gross Weight lb (kg)	Ground Bearing Pressure psi (kg/cm <sup>2</sup> )
1	Base crane, "ABC" counterweight, 550 ft (167.64m) type ZB hoist rope, full of fuel, 45 ton (40.8mt) 4-sheave hook block, and a 200 lb (90.7kg) operator	99,500 (44 905)	8.09 (0.57)

Notes: Ground bearing pressure is based on the total weight distributed evenly over the track contact area.

# Transport Drawing

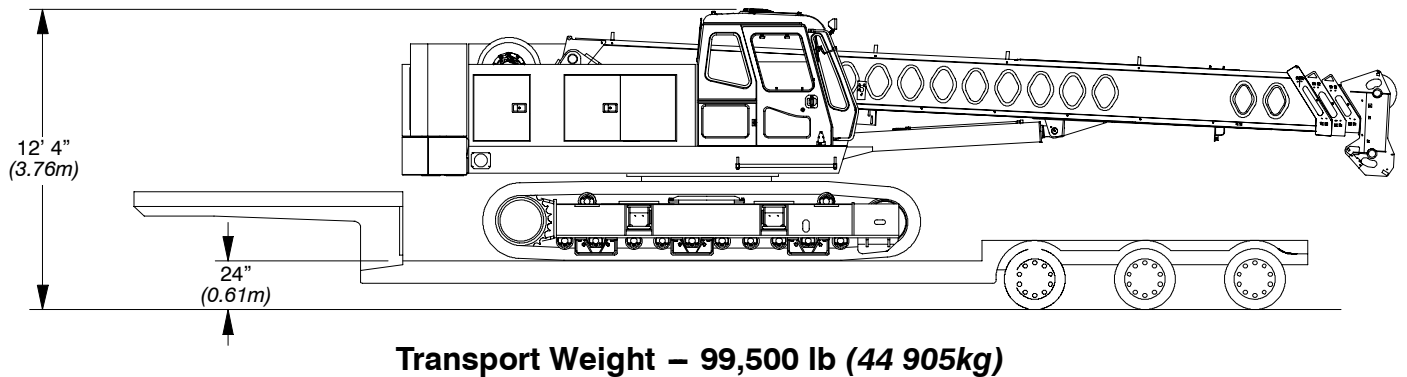

# Load Hoist Performance

## Front Drum – 18mm Wire Rope

Rope Layer	Maximum Line Pull		No Load Line Speed		Full Load Line Speed		Pitch Diameter		Layer		Total	
	lb	kg	ft/min	m/min	ft/min	m/min	in	mm	ft	m	ft	m
1	19,108	8 667	327	99.6	213	64.9	16.5	419	82	24.9	82	24.9
2	17,661	8 010	354	107.8	231	70.4	17.9	454	89	27.1	171	52.1
3	16,418	7 447	381	116.1	248	75.5	19.2	487	96	29.2	267	81.3
4	15,338	6 957	408	124.3	266	81.0	20.6	523	102	31.1	369	112.4
5	14,391	6 527	434	132.2	283	86.2	21.9	556	109	33.2	478	145.6
6	13,555	6 148	461	140.5	300	91.4	23.3	591	116	35.3	594	181.1
7	12,810	5 810	488	148.7	318	96.9	24.6	624	123	37.4	716	218.2

## Rear Drum – 5/8 in Wire Rope

Rope Layer	Maximum Line Pull		No Load Line Speed		Full Load Line Speed		Pitch Diameter		Layer		Total	
	lb	kg	ft/min	m/min	ft/min	m/min	in	mm	ft	m	ft	m
1	15,871	7 198	324	98.7	172	52.4	11.3	287	97	29.5	97	29.5
2	14,356	6 511	378	115.2	191	58.2	12.4	314	107	32.6	205	62.4
3	13,104	5 943	415	126.4	209	63.7	13.6	345	118	35.9	322	98.1
4	12,054	5 467	451	137.4	227	69.1	14.8	375	128	39.1	450	137.1
5	11,159	5 061	487	148.4	245	74.6	16.0	406	138	42.1	589	179.5
6	10,388	4 711	523	159.4	263	80.1	17.2	436	148	45.1	737	224.6

Wire Rope Application	Diameter	Type	Max. Permissible Load		Wire Rope Descriptions
			lb	kg	
Front Hoist	18mm	ZB	14,020	6 359	36 X 7 Non-Rotating, E.I.P.S., Right Regular Lay, Compacted
Optional Rear Hoist	5/8 in	ZB	11,080	5 025	36 X 7 Non-Rotating, E.I.P.S., Right Regular Lay, Compacted

# Working Areas

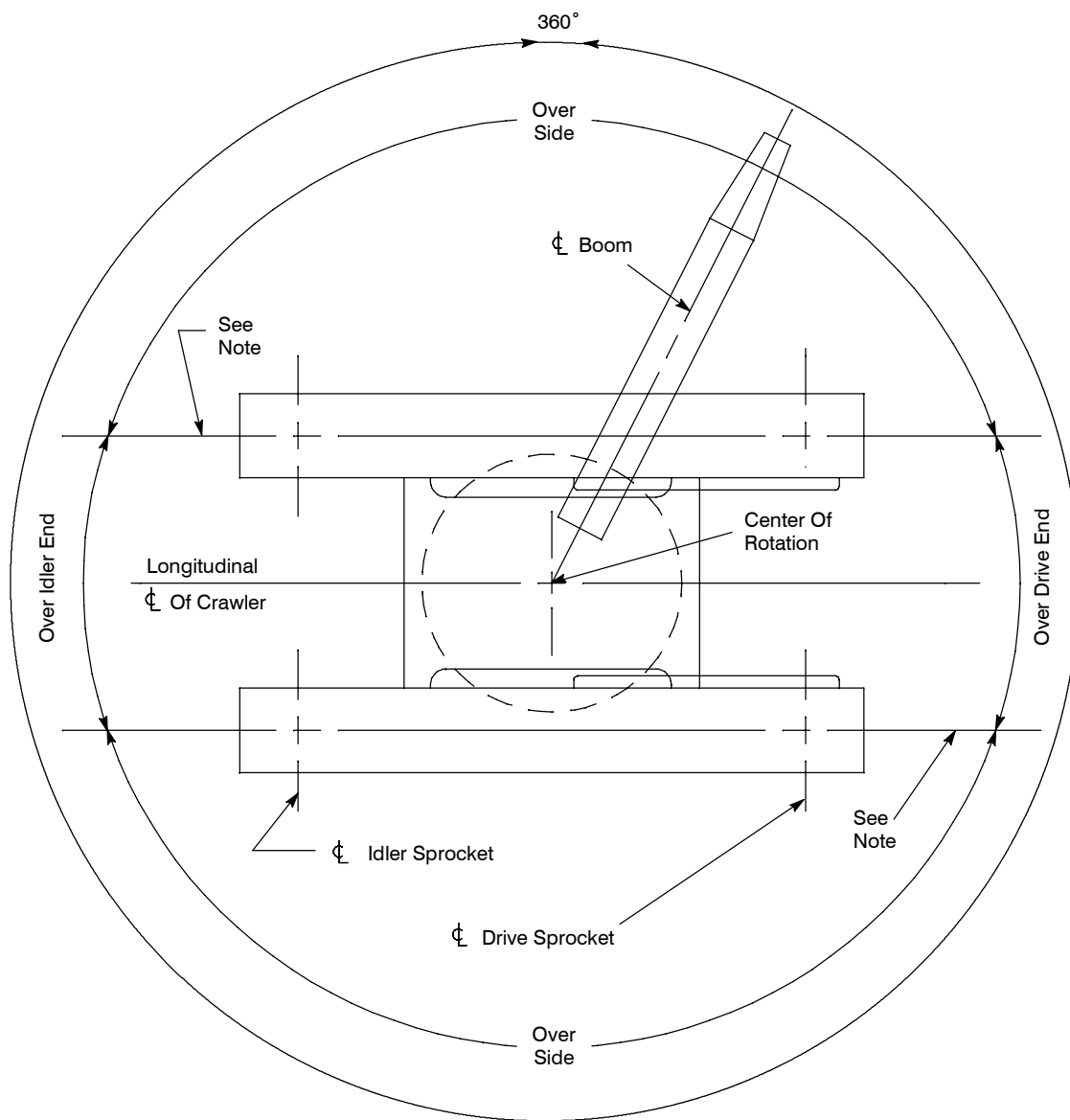

**Note:** These Lines Determine The Limiting Position Of Any Load For Operation Within Working Areas Indicated.

# Boom Extend Modes

## Boom Mode "A" (A-max)

Only inner mid section telescopes.

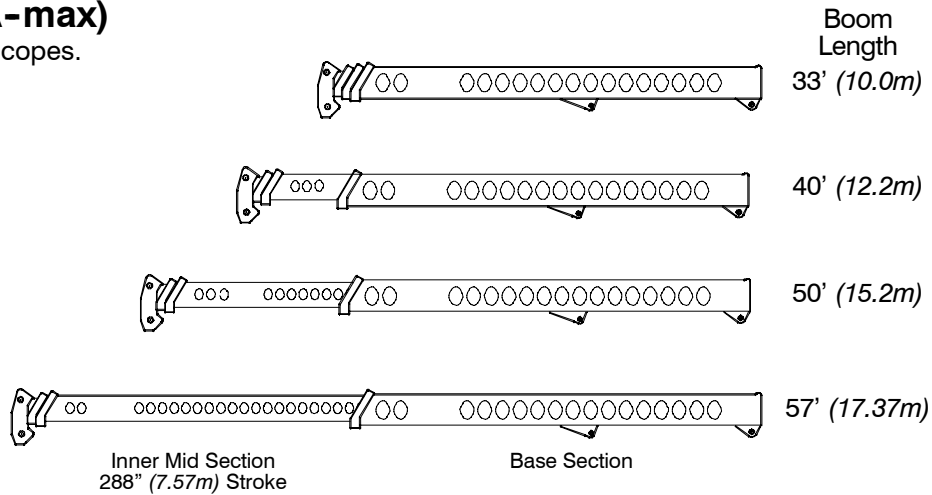

## Boom Mode "B" (Standard)

Inner mid, outer mid, and tip sections telescope simultaneously.

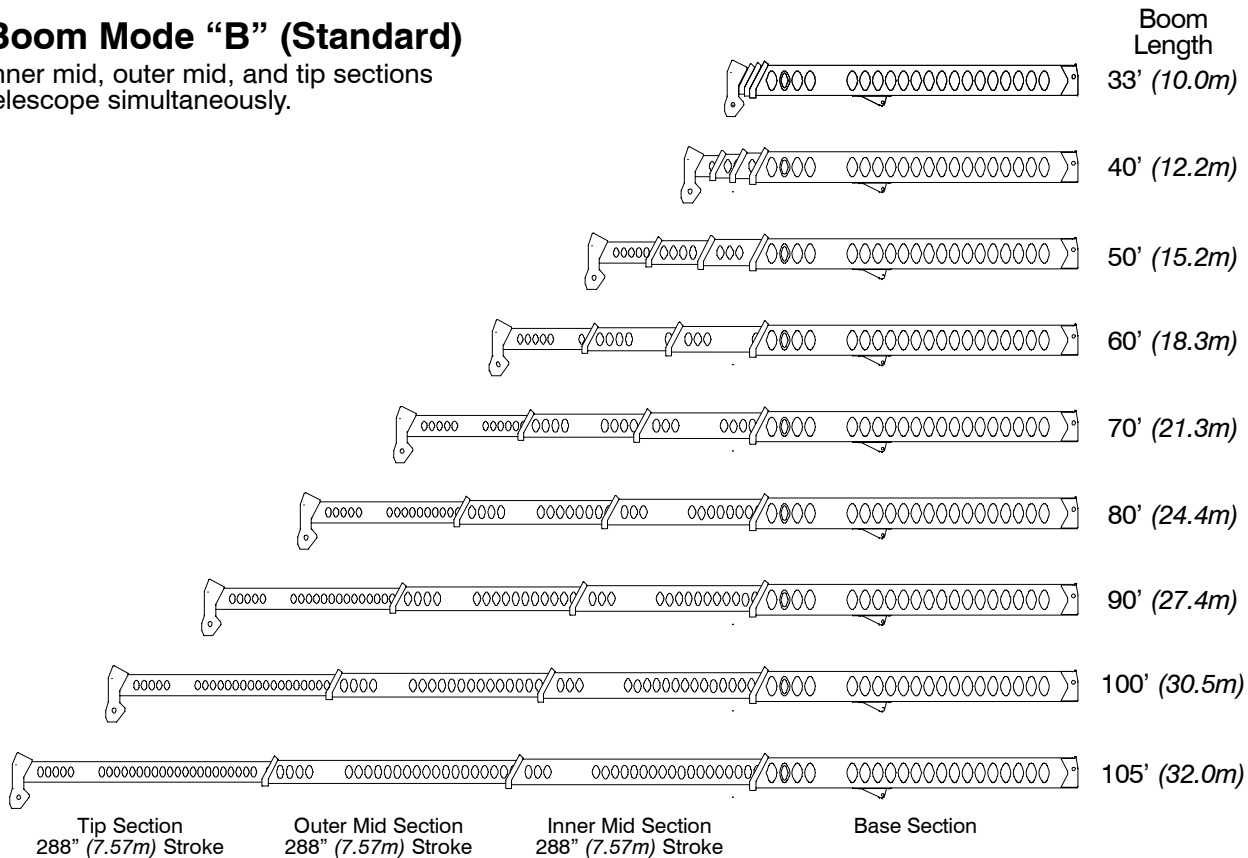

# Attachments

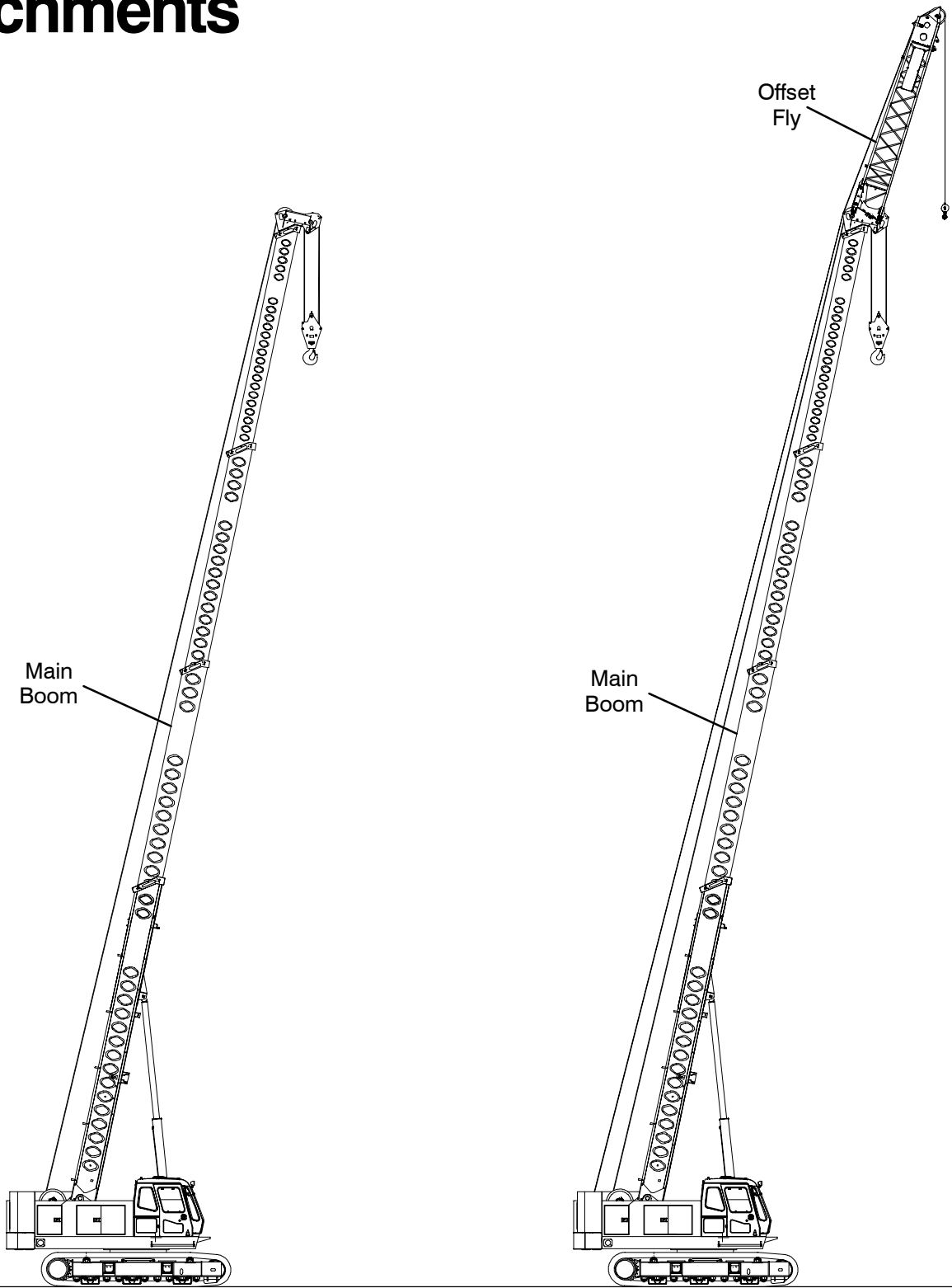

**33-105 ft (10.05-32.00m)  
Main Boom**

**79.9 ft-105 ft (24.4-32.00m) Main Boom  
With 20 ft (6.10m) Offset Fly**

# Main Boom Working Range Diagrams

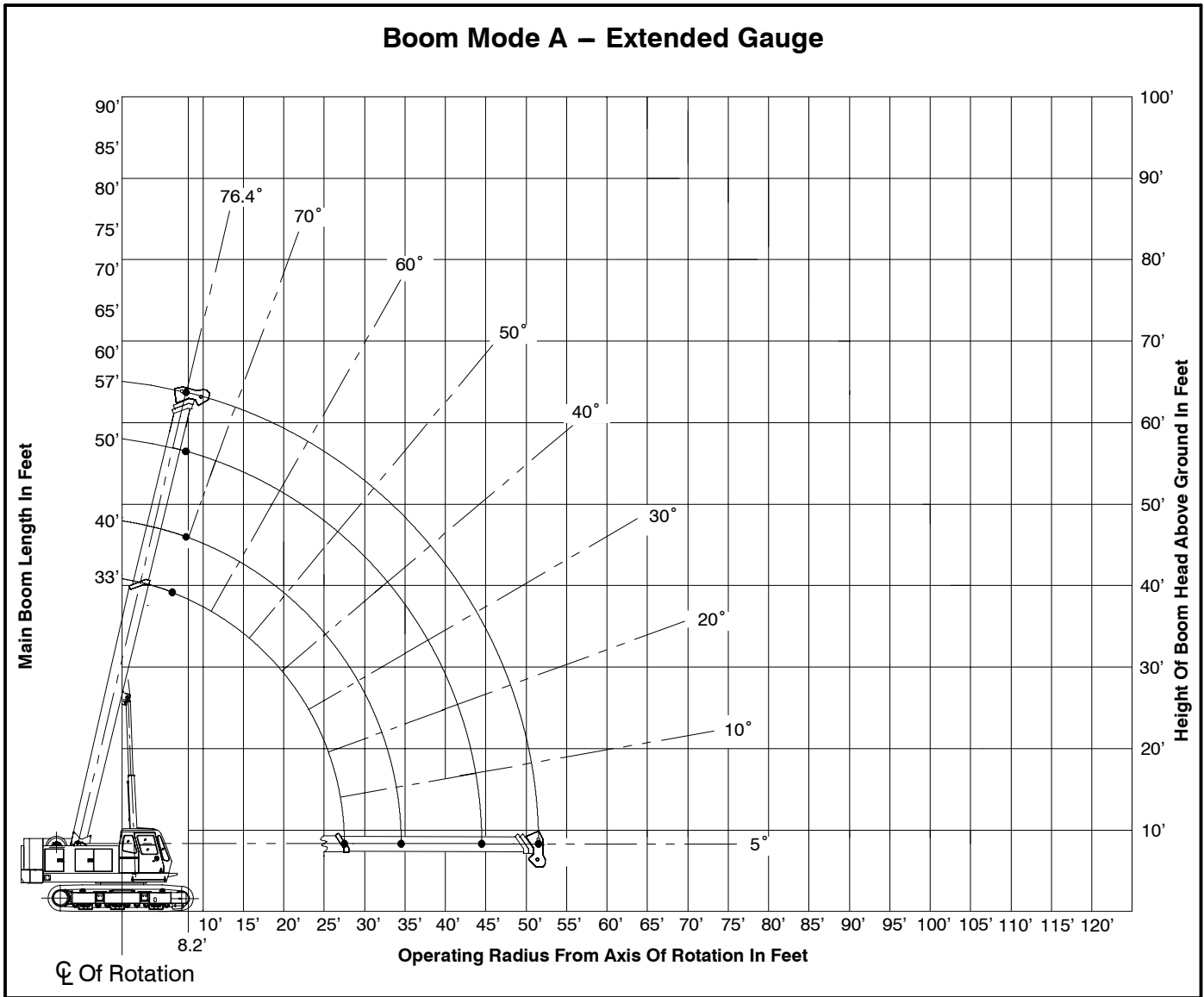

### Boom Mode B – Extended Gauge

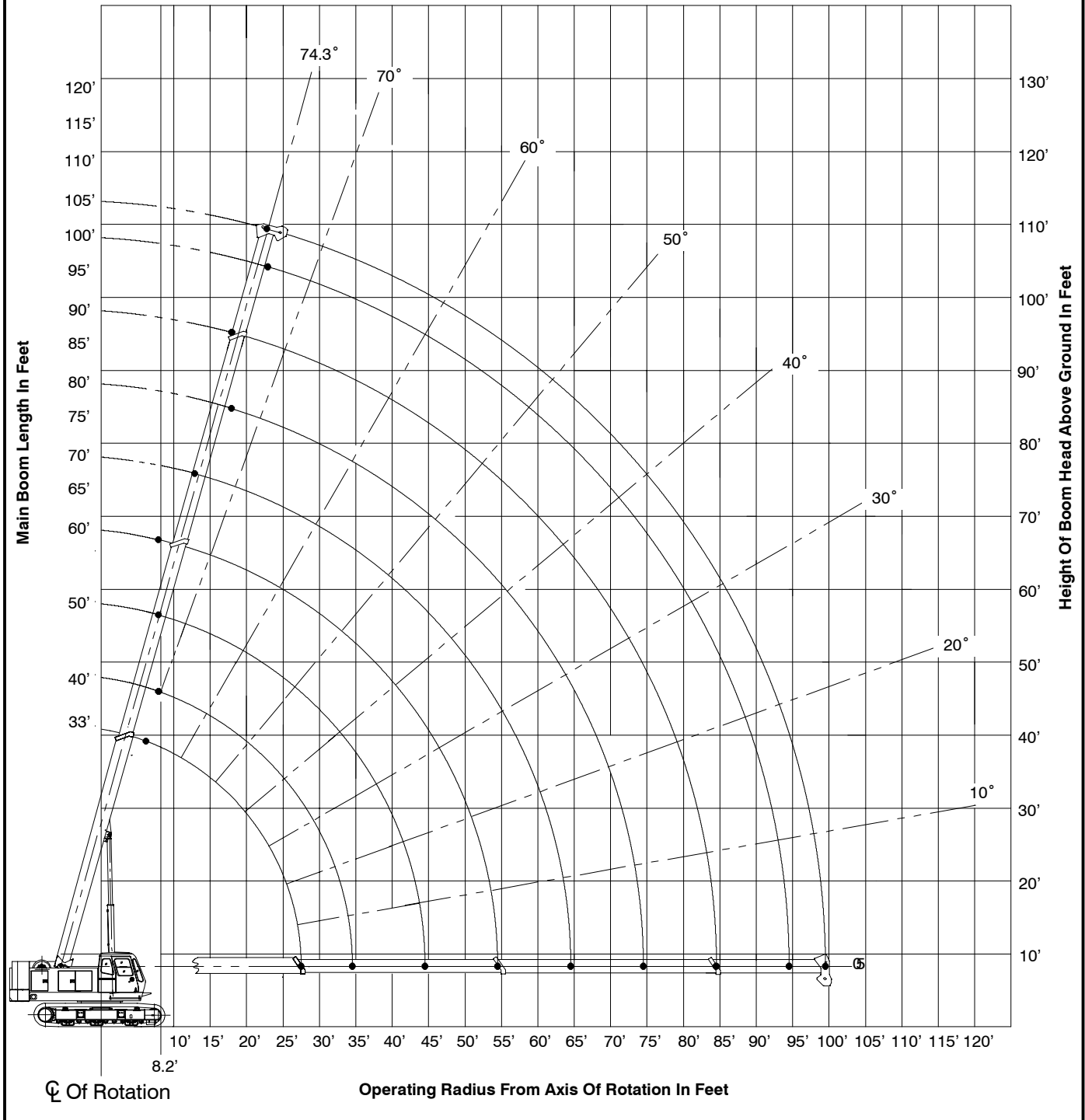

# Main Boom Load Charts

Main Boom Lift Capacity Chart – 360° Rotation – Boom Mode A – Side Frames Extended ABC [25,354lb (11 500kg)] Counterweight [All capacities are listed in kips (mt)]					
Load Radius ft (m)	Boom Length ft (m)				Load Radius ft (m)
	33 (10.1)	40 (12.2)	50 (15.2)	57 (27.4)	
8.2 (2.5)	90.0 (40.8)				8.2 (2.5)
10 (3.1)	80.0 (36.3)	72.1 (32.7)	70.5 (32.0)	43.8 (19.9)	10 (3.1)
12 (3.7)	73.8 (33.5)	72.1 (32.7)	65.6 (29.8)	43.8 (19.9)	12 (3.7)
15 (4.6)	63.1 (28.6)	62.9 (28.5)	57.4 (26.0)	42.2 (19.1)	15 (4.6)
20 (6.1)	39.6 (18.0)	39.2 (17.8)	38.7 (17.6)	34.2 (15.5)	20 (6.1)
25 (7.6)	27.9 (12.7)	27.5 (12.5)	27.1 (12.3)	26.9 (12.2)	25 (7.6)
30 (9.1)		20.6 (9.3)	20.3 (9.2)	20.1 (9.1)	30 (9.1)
35 (10.7)			15.7 (7.1)	15.5 (7.0)	35 (10.7)
40 (12.2)			12.5 (5.7)	12.3 (5.6)	40 (12.2)
45 (13.7)				9.9 (4.5)	45 (13.7)
50 (15.2)				8.0 (3.6)	50 (15.2)

This material is supplied for reference use only. Operator must refer to in-cab Crane Rating Manual and Operator's Manual to determine allowable crane lifting capacities and assembly and operating procedures.

**Main Boom Lift Capacity Chart – 360° Rotation – Boom Mode B – Side Frames Extended**  
**ABC [25,354lb (11 500kg)] Counterweight**  
**[All capacities are listed in kips (mt)]**

Load Radius ft (m)	Boom Length ft (m)									Load Radius ft (m)
	33 (10.1)	40 (12.2)	50 (15.2)	60 (18.3)	70 (21.3)	80 (24.4)	90 (27.4)	100 (30.5)	105 (32.0)	
8.2 (2.5)	90.0 (40.8)									8.2 (2.5)
10 (3.1)	80.0 (36.3)	35.0 (15.9)	35.0 (15.9)	35.0 (15.9)						10 (3.1)
12 (3.7)	73.8 (33.5)	35.0 (15.9)	35.0 (15.9)	35.0 (15.9)						12 (3.7)
15 (4.6)	63.1 (28.6)	35.0 (15.9)	35.0 (15.9)	35.0 (15.9)	35.0 (15.9)					15 (4.6)
20 (6.1)	39.6 (18.0)	35.0 (15.9)	35.0 (15.9)	35.0 (15.9)	35.0 (15.9)	30.5 (13.8)	27.1 (12.3)			20 (6.1)
25 (7.6)	27.9 (12.7)	28.3 (12.8)	28.6 (13.0)	28.8 (13.1)	28.9 (13.1)	26.3 (11.9)	23.4 (10.6)	20.9 (9.5)	17.5 (7.9)	25 (7.6)
30 (9.1)		21.3 (9.7)	21.7 (9.8)	21.9 (9.9)	22.0 (10.0)	22.1 (10.0)	20.4 (9.3)	18.6 (8.4)	17.5 (7.9)	30 (9.1)
35 (10.7)			17.1 (7.8)	17.3 (7.8)	17.4 (7.9)	17.5 (7.9)	17.5 (7.9)	16.2 (7.3)	15.7 (7.1)	35 (10.7)
40 (12.2)			13.8 (6.3)	14.0 (6.4)	14.1 (6.4)	14.2 (6.4)	14.2 (6.4)	14.3 (6.5)	13.9 (6.3)	40 (12.2)
45 (13.7)				11.6 (5.3)	11.7 (5.3)	11.8 (5.4)	11.9 (5.4)	11.9 (5.4)	11.9 (5.4)	45 (13.7)
50 (15.2)				9.6 (4.4)	9.8 (4.4)	9.9 (4.5)	10.0 (4.5)	10.0 (4.5)	10.0 (4.5)	50 (15.2)
55 (16.8)					8.3 (3.8)	8.4 (3.8)	8.4 (3.8)	8.5 (3.9)	8.5 (3.9)	55 (16.8)
60 (18.3)					7.0 (3.2)	7.1 (3.2)	7.2 (3.3)	7.2 (3.3)	7.3 (3.3)	60 (18.3)
65 (19.8)						6.1 (2.8)	6.2 (2.8)	6.2 (2.8)	6.2 (2.8)	65 (19.8)
70 (21.3)						5.2 (2.4)	5.3 (2.4)	5.3 (2.4)	5.3 (2.4)	70 (21.3)
75 (22.9)							4.5 (2.0)	4.6 (2.1)	4.6 (2.1)	75 (22.9)
80 (24.4)							3.9 (1.8)	3.9 (1.8)	3.9 (1.8)	80 (24.4)
85 (25.9)								3.4 (1.5)	3.4 (1.5)	85 (25.9)
90 (27.4)								2.9 (1.3)	2.9 (1.3)	90 (27.4)
95 (29.0)									2.5 (1.1)	95 (29.0)

This material is supplied for reference use only. Operator must refer to in-cab Crane Rating Manual and Operator's Manual to determine allowable crane lifting capacities and assembly and operating procedures.

# Main Boom + Fly Load Charts

**20 ft (6.10m) Offset Fly – 360° Rotation – Boom Mode B – Side Frames Extended**  
**ABC [25,354lb (11 500kg)] Counterweight**  
**[All capacities are listed in kips (mt)]**

Load Radius ft (m)	Boom Length ft (m)							
	2° Offset		Load Radius ft (m)	20° Offset		Load Radius ft (m)	40° Offset	
	Boom Length – ft (m)			Boom Length – ft (m)			Boom Length – ft (m)	
	33–79.9 (10.1–24.4)	80–105 (24.4–32.0)		33–79.9 (10.1–24.4)	80–105 (24.4–32.0)		33–79.9 (10.1–24.4)	80–105 (24.4–32.0)
35 (10.7)	13.8 (6.3)		35 (10.7)			35 (10.7)		
40 (12.2)	12.9 (5.9)	10.7 (4.9)	40 (12.2)	10.0 (4.5)		40 (12.2)		
45 (13.7)	12.1 (5.5)	9.9 (4.5)	45 (13.7)	9.6 (4.4)		45 (13.7)	8.2 (3.7)	
50 (15.2)	10.6 (4.8)	9.0 (4.1)	50 (15.2)	9.2 (4.2)	8.3 (3.8)	50 (15.2)	8.0 (3.6)	7.8 (3.5)
55 (16.8)	9.0 (4.1)	8.2 (3.7)	55 (16.8)	8.9 (4.0)	7.6 (3.4)	55 (16.8)	7.9 (3.6)	7.2 (3.3)
60 (18.3)	7.8 (3.5)	7.6 (3.4)	60 (18.3)	8.1 (3.7)	7.1 (3.2)	60 (18.3)	7.7 (3.5)	6.7 (3.0)
65 (19.8)	6.7 (3.0)	6.6 (3.0)	65 (19.8)	7.0 (3.2)	6.6 (3.0)	65 (19.8)	7.2 (3.3)	6.3 (2.9)
70 (21.3)	5.8 (2.6)	5.7 (2.6)	70 (21.3)	6.1 (2.8)	6.0 (2.7)	70 (21.3)	6.2 (2.8)	5.9 (2.7)
75 (22.9)	5.0 (2.3)	4.9 (2.2)	75 (22.9)	5.3 (2.4)	5.2 (2.4)	75 (22.9)	5.4 (2.4)	5.4 (2.4)
80 (24.4)	4.4 (2.0)	4.2 (1.9)	80 (24.4)	4.5 (2.0)	4.5 (2.0)	80 (24.4)		4.7 (2.1)
85 (25.9)	3.8 (1.7)	3.6 (1.6)	85 (25.9)	3.9 (1.8)	3.9 (1.8)	85 (25.9)		4.0 (1.8)
90 (27.4)	3.3 (1.5)	3.1 (1.4)	90 (27.4)	3.3 (1.5)	3.3 (1.5)	90 (27.4)		3.4 (1.5)
95 (29.0)		2.7 (1.2)	95 (29.0)		2.9 (1.3)	95 (29.0)		2.9 (1.3)
100 (30.5)		2.3 (1.0)	100 (30.5)		2.5 (1.1)	100 (30.5)		
105 (32.0)		1.9 (0.9)	105 (32.0)		2.0 (0.9)	105 (32.0)		
110 (33.5)		1.6 (0.7)	110 (33.5)		1.7 (0.8)	110 (33.5)		
115 (35.1)		1.4 (0.6)	115 (35.1)			115 (35.1)		

This material is supplied for reference use only. Operator must refer to in-cab Crane Rating Manual and Operator's Manual to determine allowable crane lifting capacities and assembly and operating procedures.

**This Page Intentionally Blank**

**Link-Belt Construction Equipment Company** Lexington, Kentucky [www.linkbelt.com](http://www.linkbelt.com)

®Link-Belt is a registered trademark. Copyright 2007. We are constantly improving our products and therefore reserve the right to change designs and specifications.